

MAGNA3

From Model D

Circulator pumps

50/60 Hz



1. Product description	3	12. Grundfos Product Center	63
Type key	4		
Model type	4		
Pump heads in twin-head pumps	4		
Performance range, MAGNA3	5		
Performance range, MAGNA3 D single-head operation	5		
Performance range, MAGNA3 D twin-head operation	6		
2. Product range	7		
3. System applications	9		
Heating systems	9		
Cooling systems	11		
Solar-heating systems	13		
4. Functions	14		
Control modes: Quick overview	15		
Operating modes	17		
Control modes	17		
Additional control mode features	22		
Multipump modes	23		
Flow estimation accuracy	24		
Readings and settings on the pump	25		
Communication	27		
5. Operating conditions	32		
General recommendations	32		
Pumped liquids	33		
Electrical data	34		
6. Construction	35		
7. Installation	37		
Mechanical installation	37		
Electrical installation	37		
Connection to power supply, terminal-connected versions	38		
8. Curve conditions	40		
Performance curves	40		
Energy efficiency index (EEI)	40		
QR code on the pump nameplate	40		
Markings and approvals	41		
9. Performance curves and technical data	42		
10. Accessories	57		
Insulating kits for air-conditioning and cooling systems	57		
CIM modules	57		
Grundfos GO	58		
External Grundfos sensors	59		
Cable for sensors	60		
Blanking flange	60		
Pipe connections	61		
11. Product numbers	62		
Single-head pumps	62		
Twin-head pumps	62		

1. Product description



TM05 8894 2813

The Grundfos MAGNA3 model D circulator pumps are designed for circulating liquids in systems with variable flow requirements where you want to optimize the setting of the pump duty point, thus reducing energy costs.

Applications

- Heating systems
 - main pump
 - mixing loops
 - heating surfaces
- air-conditioning and cooling systems
- domestic hot-water systems
- ground source heat-pump systems
- solar-heating systems.

The MAGNA3 circulator pump is perfect for both new systems as well as for replacement. The pump is ideal when operating in systems requiring an automated adjustment of pressure. This pump range is the best choice as it eliminates the need for expensive bypass valves and similar components.

Furthermore, the pump is appropriate for systems with hot-water priority as an external signal can immediately force the pump to operate according to the maximum curve, for example in solar-heating systems. When using the pumps in domestic hot-water systems, please observe local legislation regarding pump house material. Grundfos strongly recommends that you use stainless-steel pumps in domestic hot-water applications to avoid corrosion.

Duty range

Data	MAGNA3 (N) Single-head pumps	MAGNA3 D Twin-head pumps
Maximum flow rate	345 gpm (78.5 m ³ /h)	484 gpm (110 m ³ /h)
Maximum head	60 ft (18 m)	
Maximum system pressure	175 psi (1.2 MPa) (12 bar)	
Liquid temperature	14 to 230 °F (-10 to +110 °C)	

To ensure correct operation, it is important that the duty points in the system match the duty range of the pump.

Characteristic features

- AUTO_{ADAPT}.
- FLOW_{LIMIT}.
- FLOW_{ADAPT} - a combination of the AUTO_{ADAPT} control mode and FLOW_{LIMIT} function.
- Built-in Grundfos differential-pressure and temperature sensor.
- Proportional-pressure control.
- Constant-pressure control.
- Constant-temperature control.
- Constant-curve duty.
- Maximum or minimum curve duty.
- Automatic night setback.
- Self-explanatory user interface with TFT display and high quality silicone push-buttons.
- Heat energy monitor.
- Wireless multipump function.

The complete range is available for a maximum system pressure of 175 psi (12 bar, 1.2 MPa), PN 12.

Benefits

- Low energy consumption due to the AUTO_{ADAPT} function, allowing the pump to adjust automatically to external factors, such as outside temperatures and consumption patterns.
- Simple installation.
- No maintenance and long life.
- Operating log history.
- Easy and simple system optimization.
- External control and monitoring enabled via add-on modules.
- No external motor protection required.
- Insulating shells for heating systems supplied with single-head pumps.
- Wide temperature range due to thermal separation of the control box and pump media.

Type key

Code	Example	MAGNA3	(D)	80	-120	(F)	(N)	360
	Type range MAGNA3							
D	Single-head pump Twin-head pump							
	Nominal diameter (DN) of inlet and outlet ports [mm]							
	Maximum head [dm]							
F	Pipe connection Flange							
	Pump housing material Cast iron Stainless steel							
	Port-to-port length [mm]							

Model type

This data booklet covers MAGNA3 from model D. The model version is stated on the nameplate. See fig. 1.



Fig. 1 Model type on pump nameplate

TM06 7734 4017

Pump heads in twin-head pumps

The twin-head pump housing has a flap valve on the outlet side. The flap valve seals off the port of the idle pump housing to prevent the pumped liquid from running back to the inlet side. See fig. 2. Due to the flap valve, there is a difference in the hydraulics between the two heads. See fig. 3.



Fig. 2 Twin-head pump housing with flap valve

TM06 1566 2514

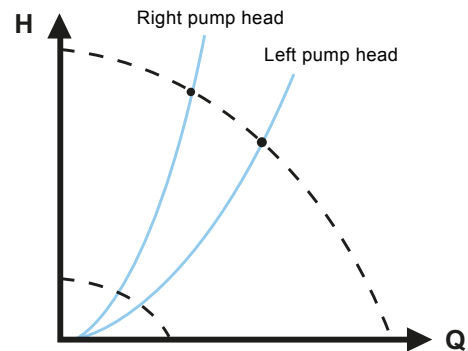

Fig. 3 Hydraulic difference between the two heads

TM06 1566 2514

Performance range, MAGNA3

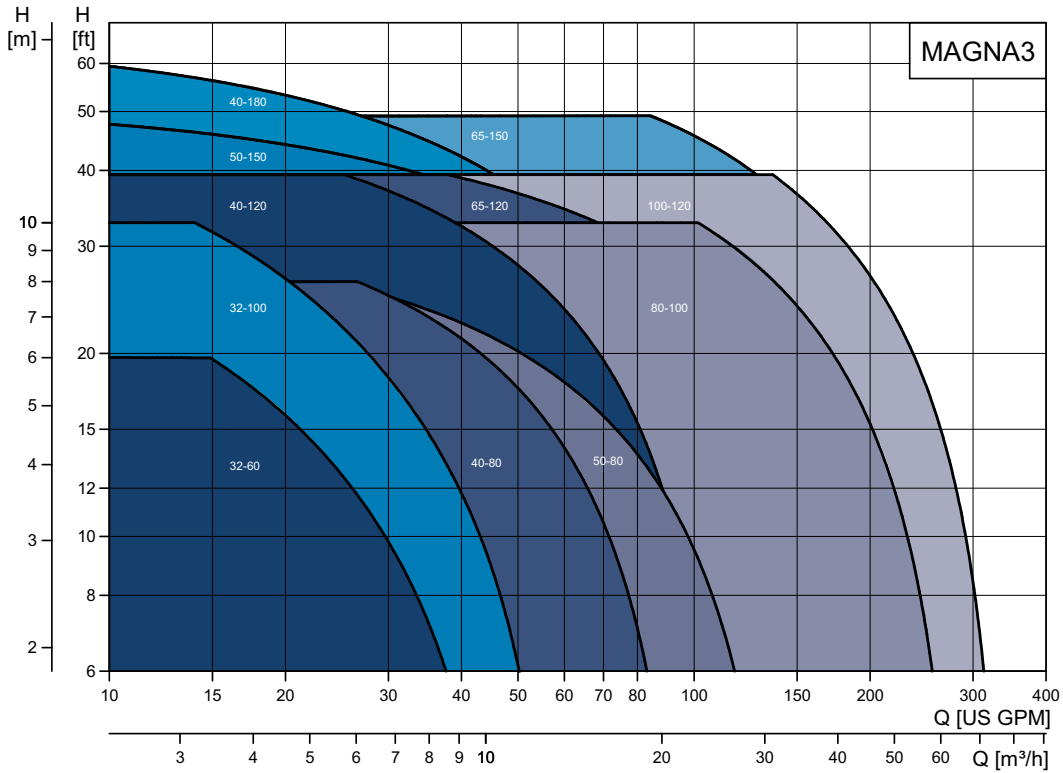

Fig. 4 Performance range, MAGNA3

TM05 7654 2818

Performance range, MAGNA3 D single-head operation

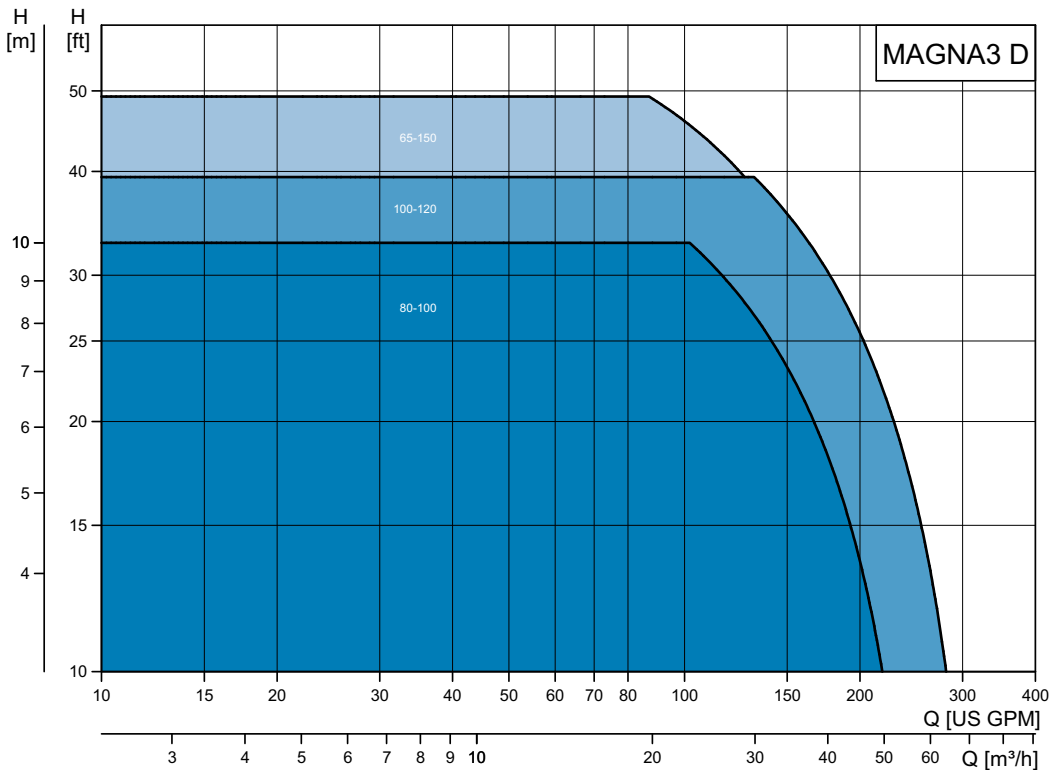

Fig. 5 Performance range, MAGNA3 D single-head operation

TM05 7655 2818

Performance range, MAGNA3 D twin-head operation

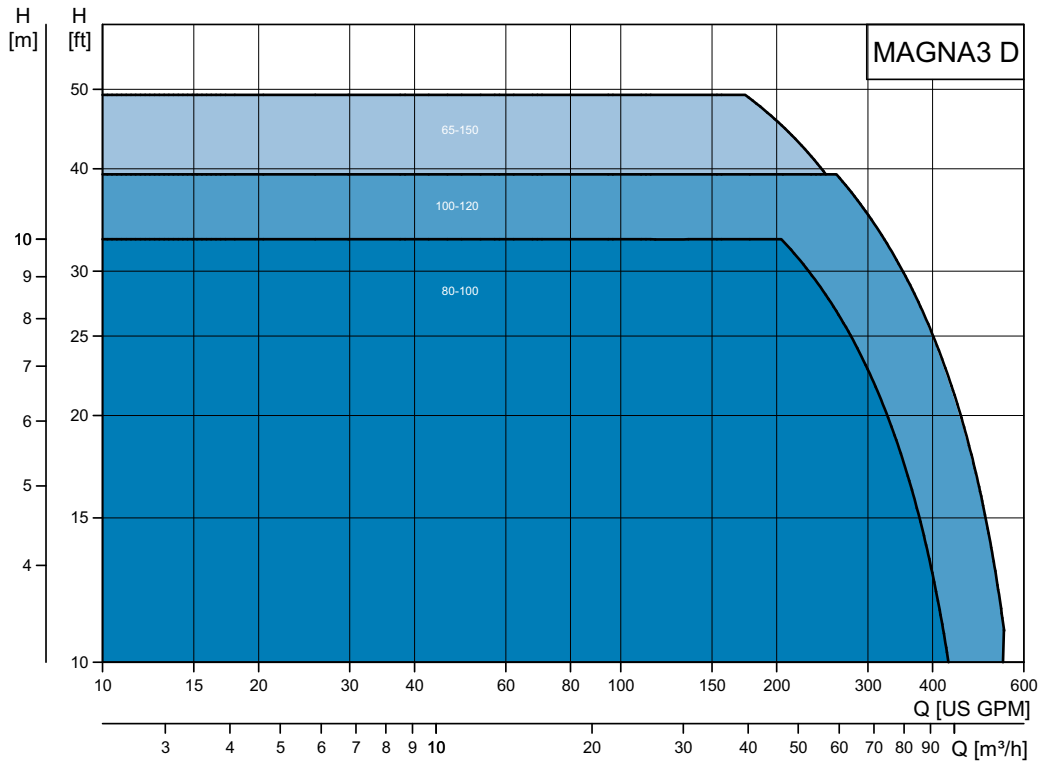

Fig. 6 Performance range, MAGNA3 D twin-head operation

TM05 7656 2818

2. Product range

	Cast iron		Stainless steel (N)		Page reference
	115 V	230 V	115 V	230 V	
Single-head pump models					
MAGNA3 32-60 F (N)		98126820		98126822	43
MAGNA3 32-100 F (N)		98126824		98126826	44
MAGNA3 40-80 F (N)	98126800	98126828	98126802	98126830	45
MAGNA3 40-120 F (N)	98126804	98126832	98126806	98126834	46
MAGNA3 40-180 F (N)	98126808	98126836	98126810	98126838	47
MAGNA3 50-80 F (N)	98126812	98126840	98126814	98126842	48
MAGNA3 50-150 F (N)	98126816	98126844	98126818	98126846	49
MAGNA3 65-120 F (N)	98124696	98126848	98124702	98126850	50
MAGNA3 65-150 F (N)	-	98126852	-	98126854	51
MAGNA3 80-100 F (N)	-	98126856	-	98126858	53
MAGNA3 100-120 F (N)	-	98126860	-	98126862	55
Twin-head pump models					
MAGNA3 D 65-150 F	-	98126863	-	-	52
MAGNA3 D 80-100 F	-	98126864	-	-	54
MAGNA3 D 100-120 F	-	98126865	-	-	56

Pump selection

All pumps have a "best point" (η_{\max}), indicating where the pump is working most efficiently.

Consider the parameters in the following section.

Pump size

The system characteristic is used together with the performance curve of the pump for sizing and correct pump selection.

The selection of pump size must be based on the following:

- required maximum flow
- maximum pressure loss in the system.

Refer to the system characteristics to determine the duty point. See fig. 7.

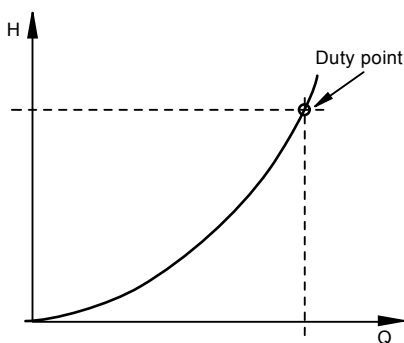

Fig. 7 System characteristic

TM02 2040 3301

Operating conditions

You must check whether the operating conditions are fulfilled, i.e.:

- liquid quality and temperature
- ambient conditions
- minimum inlet pressure
- maximum operating pressure.

See also [Operating conditions](#), page 32.

Closed valve operation

A MAGNA3 pump can operate at any speed against a closed valve for several days without damage to the pump. However, Grundfos recommends to operate at the lowest possible speed curve to minimize energy losses. There are no minimum flow requirements.

Note: Do not close inlet and outlet valves simultaneously, always keep one open when the pump is running. Media- and ambient temperatures must never exceed the specified temperature range.

Control modes

- $AUTO_{ADAPT}$ (factory setting) which is suitable for most installations.
- $FLOW_{ADAPT}$ in systems where flow limitation is required.
- Proportional-pressure control in systems with considerable pressure losses in relation to large flow variations.
- Constant-pressure control in systems with insignificant pressure losses in relation to large flow variations.
- Constant-temperature control in heating systems with a fixed system characteristic, for example domestic hot-water systems.
- Differential-temperature control in heating and cooling systems.
- Constant-curve duty.

For further information on control and operating modes, see [Functions](#), page 14.

Automatic determination of the setpoint

If you know the duty point, you can enter the value on the display when setting the pump. The pump then automatically calculates the corresponding setpoint. See fig. 8.

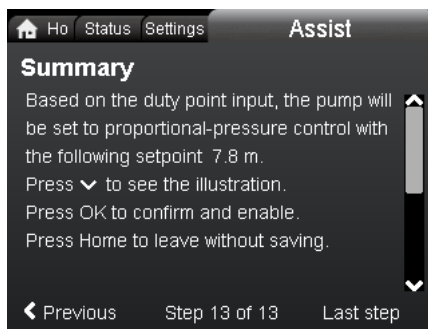

4.1.1.0.0.0 - 13A

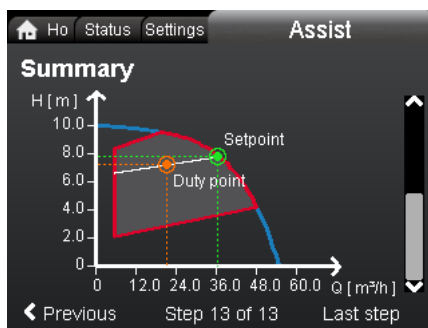

4.1.1.0.0.0 - 13B

Fig. 8 Example of setpoint calculation based on a chosen control mode and entered Q and H values

Communication

The Grundfos CIM modules (Communication Interface Module) enable the MAGNA3 to connect to standard fieldbus networks, offering substantial benefits:

- complete process control and monitoring
- modular design, prepared for future requirements
- based on standard functional profiles
- simple configuration and easy installation
- open communication standards
- reading warning and alarm indications.

For further details, see [CIM modules](#), page 27.

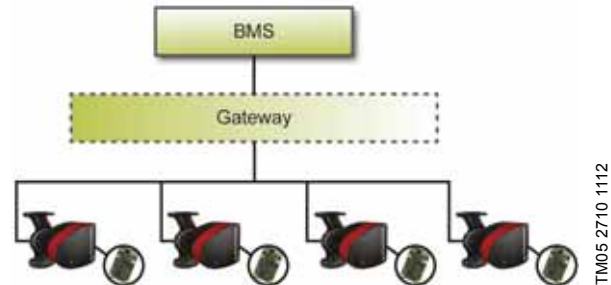

TM05 2710 1112

Fig. 9 Example of a typical building management system (BMS)

Note: A gateway is a device that facilitates the transfer of data between two different networks based on different communication protocols.

3. System applications

Heating systems

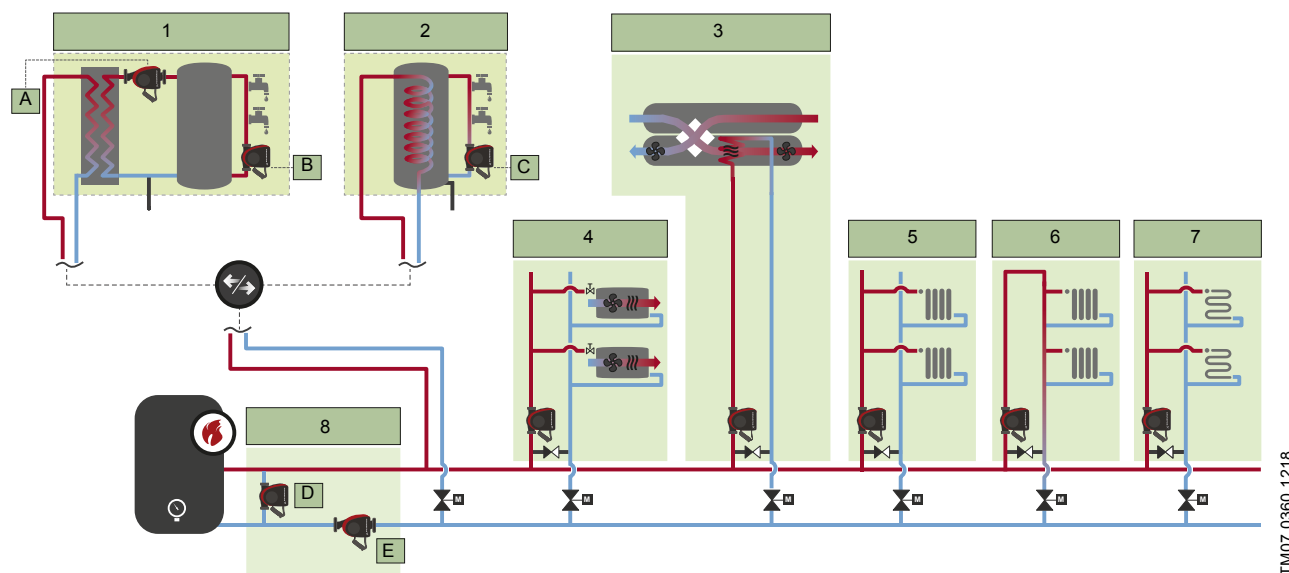

TM07 0360 1218

Fig. 10 Functional drawing of a heating system in a commercial building

Pos.	Description
1	Hot water
A	Charging pump
B	Recirculation
2	Hot water
C	Recirculation
3	Air handling unit
4	Fan coil unit
5	Radiator two-pipe system
6	Radiator one-pipe system
7	Underfloor/ceiling
8	Boiler pump
D	Shunt/buffer
E	"Primary only" system

Main pumps

Due to variations in the heat demand and flow rate, we always recommend that you use speed-controlled MAGNA3 pumps in a heating system, either single-head pumps connected in parallel or twin-head pumps. Single-head pumps connected in parallel have several advantages. In alternating operation, each pump is sized for 100 % flow. In this operating mode, the second pump functions as backup for higher reliability. As the pumps alternate, an equal number of operating hours is ensured. Cascade operation of pumps connected in parallel meets demands in high-flow systems with low differential temperature (Δt), and 50 % backup is ensured at the same time.

The twin-head pump saves installation time and costs. By speed-controlling all pumps, you can obtain maximum energy saving as the pumps will run at their best efficiency point (BEP).

In a variable-flow system, we recommend that you control the main pump in $AUTO_{ADAPT}$ or proportional-pressure mode.

However, if a load (e.g. a radiator) is far from the pump, it can be advantageous to install a differential pressure sensor across this load and use a setpoint for differential pressure.

By using the $FLOW_{ADAPT}$ function to ensure correct balancing of the system, the need for pump throttling valves can be reduced significantly.

The built-in heat energy monitor allows monitoring of the heat energy consumption in the system only for optimization purposes.

Air handler heating coils

The performance of heating surfaces is controlled by the heating-water temperature and the flow rate. For this purpose, we recommend that you install variable-flow mixing loops at the heating surfaces. A speed-controlled mixing-loop pump is ideal for adaptation to the varying loads in a heating surface. In this case, MAGNA3 will have full authority, making external pump throttling valves superfluous.

Domestic hot water

For domestic hot-water circulation, the constant-temperature control mode will ensure a constant temperature in the recirculation pipe, without the use of separate thermostatic valves, thus obtaining maximum comfort.

Mixing loops

Due to variations in use, flow-pipe temperature and heat demand in different parts of the building, the heating system must be divided into zones controlled by independent mixing loops. Due to the flow variations, a speed-controlled mixing-loop pump will have authority in the system. This will help obtain a better hydraulic balance in the overall system. Speed control of the pump via selection of a control mode, depending on system application, ensures maximum energy saving. See [Control modes](#), page 17.

Advantages of using mixing loops:

- Reduced excessive differential pressure in the system and hereby reduced risk of overflow
- Increased control ability as the loop is provided with the exact flow rate and temperature demand.

Cooling systems

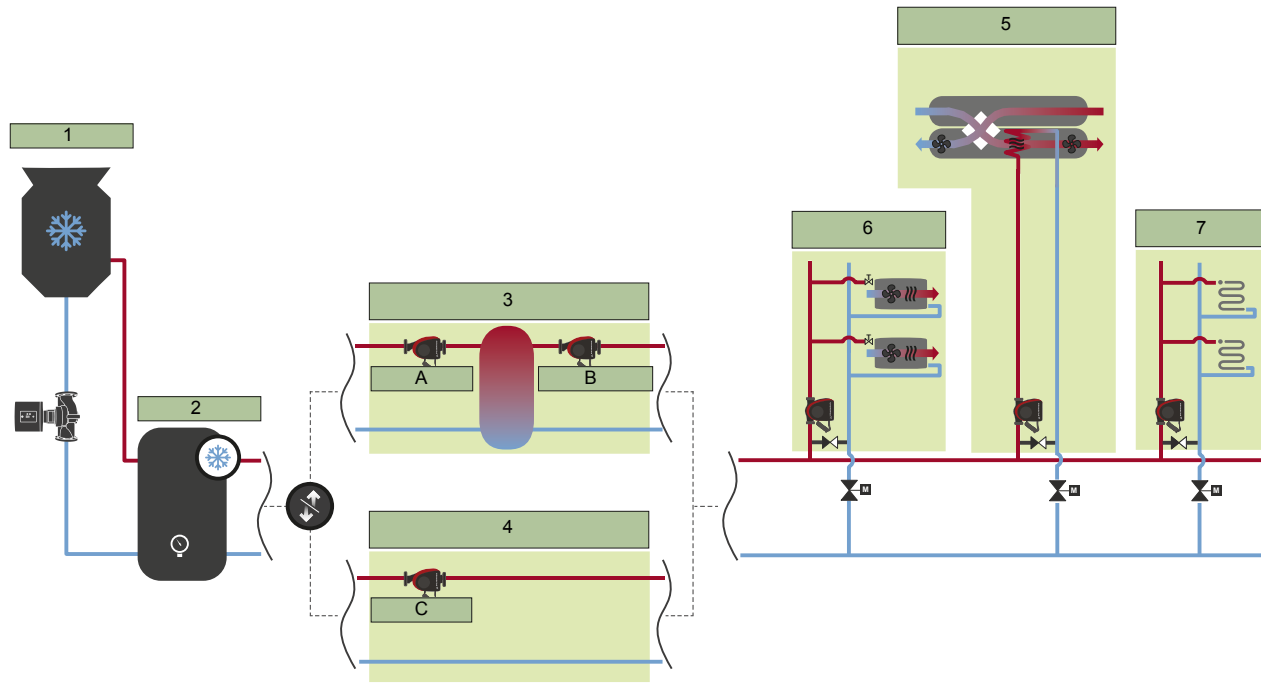

TM07 0358 1218

Fig. 11 Functional drawing of a cooling system in a commercial building

Pos.	Description
1	Cooling tower
2	Cooling source
3	Primary/secondary system
A	Primary pump
B	Secondary pump
4	"Primary only" system
C	Primary pump
5	Air handling unit
6	Fan coil unit
7	Underfloor/ceiling

Primary and secondary pumps

Due to variations in the cooling demand and flow rate, we recommend that you use speed-controlled MAGNA3 pumps in a cooling system, either single-head pumps connected in parallel or twin-head pumps. Single-head pumps connected in parallel have several advantages. In alternating operation, each pump is sized for 100 % flow. In this operating mode, the second pump functions as backup for higher reliability. As the pumps alternate, an equal number of operating hours is ensured. Cascade operation of pumps connected in parallel meets demands in high-flow systems with low differential temperature (Δt), and 50 % backup is ensured at the same time.

The twin-head pump saves installation time and costs. By speed-controlling all pumps, you can obtain maximum energy saving as the pumps will run at their best efficiency point (BEP).

In a variable-flow system, we recommend that you control secondary pumps in *AUTO_{ADAPT}* or proportional-pressure mode with a differential-pressure sensor in the flow pipe with the lowest pressure. This ensures maximum energy saving.

The built-in heat energy monitor allows monitoring of the heat energy consumption in the system.

Air handler cooling coils

The performance of cooling surfaces is controlled by the cooling-water temperature and the flow rate. For this purpose, we recommend that you install variable-flow mixing loops at the cooling surfaces. A speed-controlled mixing-loop pump is ideal for adaptation to the varying loads in a cooling surface. In this case, MAGNA3 will have full authority, eliminating the need for external pump throttling valves. The *FLOW_{LIMIT}* ensures that the rated flow is never exceeded.

Heat recovery system

The heat recovery system is of paramount importance for the overall energy efficiency of an air-conditioning or cooling system. Due to high load and temperature variations in the system, it is important to use variable-speed pumps in a heat recovery system.

Cooling tower

Due to chiller load variations and changes in the temperature and moisture of the ambient air, the cooling-tower flow rate is continuously changing. In order to achieve maximum energy saving, cooling-tower pumps have to be able to adapt to these varying conditions. The pumps are controlled by a temperature setpoint which is measured at the condenser of the chiller. In this system, MAGNA3 will have full authority, eliminating the need for pump throttling valves. The *FLOW_{LIMIT}* ensures that the rated flow is never exceeded.

Mixing loops

Due to the risk of condensation, the flow-pipe temperature through a cooling ceiling or floor must never be lower than the dew point temperature of the indoor air. The dew point temperature varies due to variations in indoor moisture load and outdoor thermal conditions. The result is that the cooling-water setpoint has to be controlled. A mixing loop is ideal for obtaining the correct temperature in order to adapt to the varying setpoint.

Due to continuous cooling-load variations in the building cooling zones, the cooling performance in cooling ceilings and floors is controlled by motor valves via zone control units, and therefore you must always use a speed-controlled mixing-loop pump.

Solar-heating systems

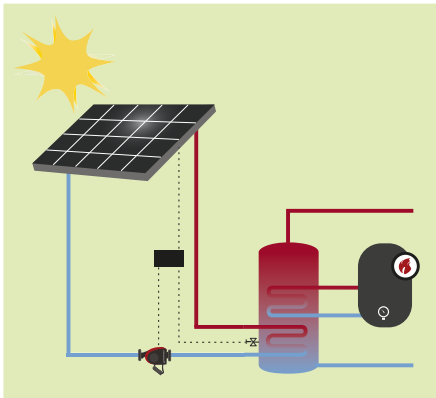

Fig. 12 Functional drawing of a solar-heating system

Main pumps

Solar-heating systems operate with very low flow rates compared to other heating systems, however, with relatively large pressure losses. With a conventional circulator pump, the flow must be controlled with a valve resulting in a significantly higher power consumption. To achieve major reductions in energy consumption, MAGNA3 is optimized with the $FLOW_{ADAPT}$ / $FLOW_{LIMIT}$ control mode for operation specifically under these conditions.

Ground source heat pump systems (GSHP)

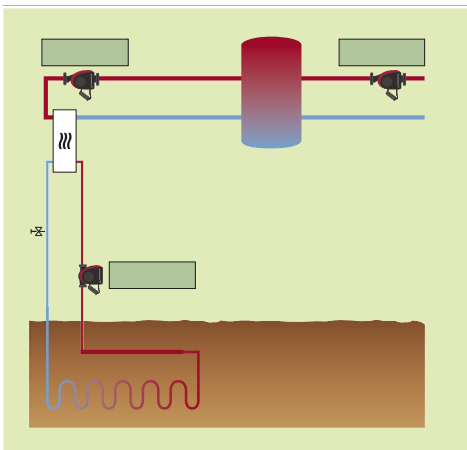

Fig. 13 Ground source heat pump system in a commercial building

Pos.	Description
1	Heat pump

Main pumps

MAGNA3 is optimized for operation as a circulator pump in a closed-loop pipe system which is buried in the ground and filled with a mixture of water and antifreeze agent. MAGNA3 is therefore ideal for large ground source heat pump systems for commercial buildings.

MAGNA3 is designed for pumping liquids down to +14 °F (-10 °C). The pump can use all known antifreeze agent compositions.

It is important to note that all components are highly energy-efficient. No other circulator pump performs better in GSHP systems than MAGNA3 with the $FLOW_{ADAPT}$ / $FLOW_{LIMIT}$ control mode.

Use the benefit of the inputs and outputs of MAGNA3 to control the pump together with the heat pump.

Installation and commissioning

When installing MAGNA3, no external pressure sensor or motor protection is required. Installation is simple thanks to the built-in differential-pressure and temperature sensor, which enables proportional-pressure control without the installation of a sensor in the system.

In systems where a differential pressure is desired at a certain point of the system, you must install an external pressure sensor. See [Electrical data](#), page 34.

Pump selection is based on the required flow and calculated pressure losses. We recommend that you do not oversize the pump as it will lead to unnecessarily high energy consumption.

MAGNA3 features the $FLOW_{LIMIT}$ function. In circuits where MAGNA3 has full authority, the need for external pump throttling valves is eliminated. The $FLOW_{LIMIT}$ ensures that the rated flow is never exceeded.

TM07 0367 1218

TM05 3422 1312

4. Functions

	Page
Operating modes	17
Normal (control modes enabled)	17
Stop	17
Minimum curve	17
Maximum curve	17
Control modes	17
AUTO _{ADAPT} (factory setting)	17
FLOW _{ADAPT}	18
Proportional pressure	19
Constant pressure	19
Constant temperature	20
Differential temperature	20
Constant curve	21
Additional control mode features	22
FLOW _{LIMIT}	22
Automatic Night Setback	23
Multipump modes	23
Alternating operation	23
Backup operation	23
Cascade operation	23
Readings and settings on the pump	25
Operating panel and display	25
Operating status	25
Pump performance	25
Warning and alarm	25
Heat energy monitor	26
Operating log	26
Grundfos Eye (status indicator)	26
Communication	27
Wireless Grundfos GO	27
Wireless GENlair connection	27
Pump information to BMS via CIM modules	27
Bus via GENibus	28
Bus via LonWorks	28
Bus via PROFIBUS DP	28
Bus via Modbus RTU	28
Bus via BACnet MS/TP	28
Digital inputs	29
Relay outputs	30
Analog input for external sensor	30
External setpoint function	31

Control modes: Quick overview

AUTO_{ADAPT}

- We recommend this control mode for most heating systems.
- During operation, the pump automatically makes the necessary adjustment to the actual system characteristic.

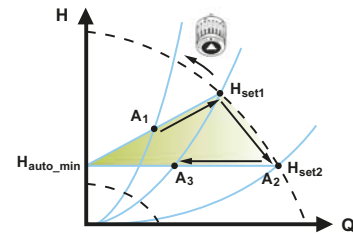

FLOW_{ADAPT}

The FLOW_{ADAPT} control mode combines a control mode and a function:

- The pump is running in AUTO_{ADAPT}.
- The delivered flow from the pump will never exceed a selected FLOW_{LIMIT}.

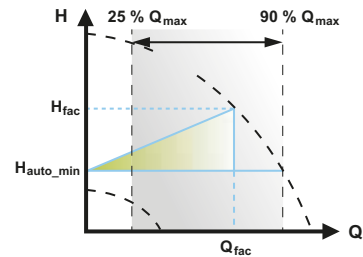

Proportional pressure

- Used in systems with relatively large pressure losses in the distribution pipes.
- The head of the pump will increase proportionally to the flow in the system to compensate for the large pressure losses in the distribution pipes.

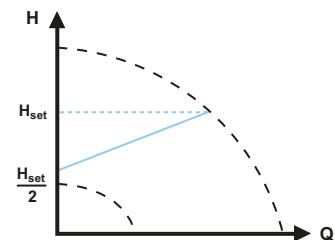

Constant pressure

- We recommend this control mode in systems with relatively small pressure losses.
- The pump head is kept constant, independent of the flow in the system.

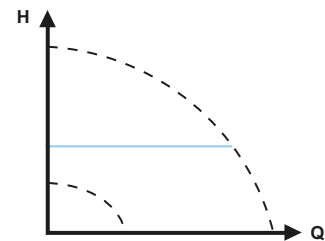

Constant temperature

In heating systems with a fixed system characteristic, for example domestic hot-water systems, the control of the pump according to a constant return-pipe temperature is relevant.

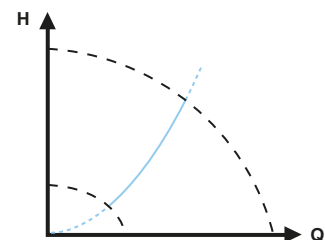

Differential temperature

- Ensures a constant differential temperature drop across heating and cooling systems.
- The pump will maintain a constant differential temperature between the pump and the external sensor.

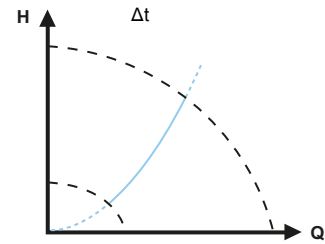

Constant curve

- The pump can be set to operate according to a constant curve, like an uncontrolled pump.
- Set the desired speed in % of the maximum speed in the range from minimum to 100 %.

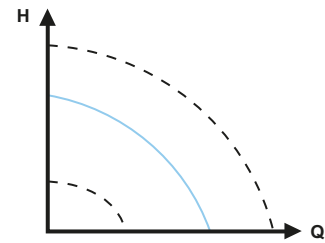

For multipump modes, see [Multipump modes](#), page 23.

Operating modes

Normal

The pump runs according to the selected control mode.

Note: You can select the control mode and setpoint even if the pump is not running in Normal mode.

Stop

The pump stops.

Min.

You can use the minimum curve mode in periods where a minimum flow rate is required.

This operating mode is for instance suitable for manual night setback if automatic setback is not desired.

Max.

You can use the maximum curve mode in periods where a maximum flow rate is required.

This operating mode is for instance suitable for hot-water priority.

You can select the normal, stop, min. and max. operating modes directly by use of the built-in digital inputs. See [Connection to power supply, terminal-connected versions](#), page 38.

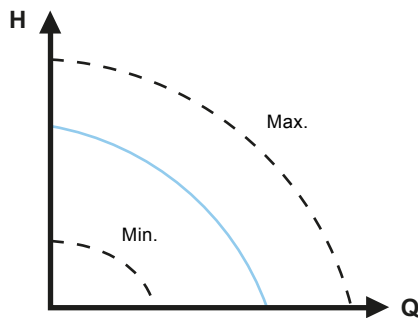

Fig. 14 Maximum and minimum curves

Control modes

Factory setting

The pumps have been factory-set to AUTO_{ADAPT} without automatic night setback, which is suitable for most installations.

The setpoint has been factory-set. See [Readings and settings on the pump](#), page 25.

AUTO_{ADAPT}

We recommend the AUTO_{ADAPT} control mode for most heating systems, especially in systems with relatively large pressure losses in the distribution pipes, and in replacement situations where the proportional-pressure duty point is unknown.

This control mode has been developed specifically for heating systems and we do not recommend it for air-conditioning and cooling systems.

Characteristics and key benefits

- Automatically adjusts the pump to actual system characteristics.
- Ensures minimum energy consumption and a low noise level.
- Reduced operating costs and increased comfort .

Technical specifications

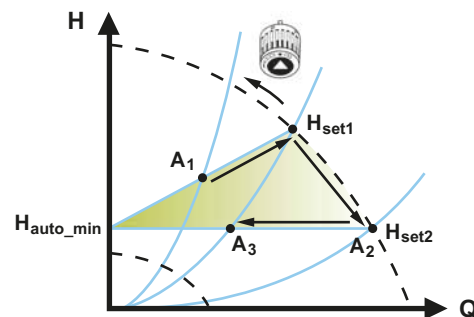

Fig. 15 AUTO_{ADAPT} control

- A₁: Original duty point
- A₂: Lower registered head on the max. curve
- A₃: New duty point after AUTO_{ADAPT} control
- H_{set1}: Original setpoint
- H_{set2}: New setpoint after AUTO_{ADAPT} control
- H_{fac}: See page 25
- H_{auto_min}: A fixed value of 1.5 m

The AUTO_{ADAPT} control mode is a form of proportional-pressure control where the control curves have a fixed origin, H_{auto_min}.

When you have enabled AUTO_{ADAPT}, the pump will start with the factory setting, H_{fac} = H_{set1}, corresponding to approximately 55 % of its maximum head, and then adjust its performance to A₁. See fig. 15.

When the pump registers a lower head on the maximum curve, A₂, the AUTO_{ADAPT} function automatically selects a correspondingly lower control curve, H_{set2}. If the valves in the system close, the pump adjusts its performance to A₃. See fig. 15.

Note: Manual setting of the setpoint is not possible.

TM05 2446 5111

TM05 2452 1312

FLOW_{ADAPT}

The FLOW_{ADAPT} control mode combines AUTO_{ADAPT} and FLOW_{LIMIT}, meaning that the pump runs AUTO_{ADAPT} while at the same time ensuring that the flow rate never exceeds the entered FLOW_{LIMIT} value. This control mode is suitable for systems where a maximum flow limit is desired and where a steady flow through the boiler in a boiler system is required. Here, no extra energy is used for pumping too much liquid into the system.

In systems with mixing loops, you can use FLOW_{ADAPT} to control the flow in each loop.

Characteristics and key benefits

- The dimensioned flow for each zone (required heat energy) is determined by the flow from the pump. This flow rate can be set precisely in the FLOW_{ADAPT} control mode without using throttling valves.
- When the flow rate is set lower than the balancing valve setting, the pump will ramp down instead of losing energy by pumping against a balancing valve.
- Cooling surfaces in air-conditioning systems can operate at high pressure and low flow rate.

Note: The pump cannot reduce the flow rate on the inlet side, but is able to control that the flow rate on the outlet side is at least the same as on the inlet side, as the pump has no built-in valve.

Technical specifications

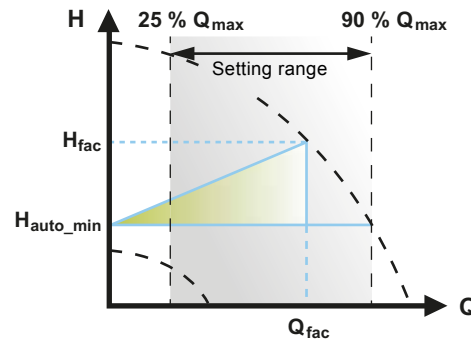

Fig. 16 FLOW_{ADAPT} control

The factory setting of the FLOW_{ADAPT} is the flow rate where the AUTO_{ADAPT} factory setting meets the maximum curve. See fig. 16.

The typical pump selection is based on the required flow rate and calculated pressure losses. The pump is typically oversized by 30 to 40 % to ensure that it can overcome the pressure losses in the system. Under these conditions, the full benefit of AUTO_{ADAPT} cannot be obtained.

To adjust the maximum flow rate of this "oversized" pump, balancing valves are built into the circuit to increase the resistance and thus reduce the flow rate.

The FLOW_{ADAPT} function reduces the need for a pump throttling valve, see fig. 17, but does not eliminate the need for balancing valves in heating systems.

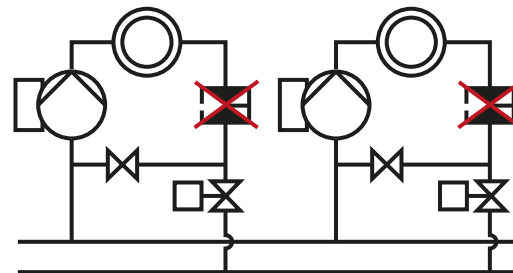

Fig. 17 Reduced need for a pump throttling valve

TM05 3334 1312

TM05 2685 1212

Proportional pressure

Proportional pressure is suitable in systems with relatively large pressure losses in the distribution pipes and in air-conditioning and cooling systems:

- Two-pipe heating systems with thermostatic valves and the following:
 - very long distribution pipes
 - strongly throttled pipe balancing valves
 - differential-pressure regulators
 - large pressure losses in the parts of the system through which the entire amount of water flows, for example a boiler, heat exchanger and distribution pipe up to the first branching.
- Primary circuit pumps in systems with large pressure losses in the primary circuit.
- Air-conditioning systems with the following:
 - heat exchangers (fan coils)
 - cooling ceilings
 - cooling surfaces.

Characteristics and key benefits

- The head of the pump increases proportionally to the flow rate in the system.
- Compensates for large pressure losses in the distribution pipes.

Technical specifications

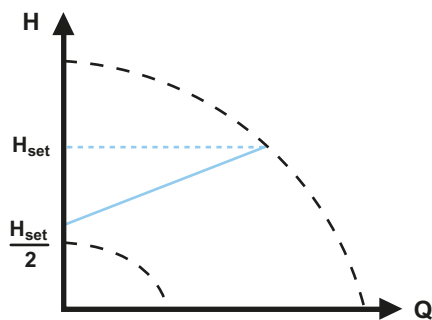

Fig. 18 Proportional-pressure control

The head against a closed valve is half the setpoint H_{set} .

TM05 2448 1212

Constant pressure

A constant pressure is advantageous in systems with relatively small pressure losses in the distribution pipes:

- Two-pipe heating systems with thermostatic valves:
 - dimensioned for natural circulation
 - small pressure losses in the parts of the system through which the entire amount of water flows, for example a boiler, heat exchanger and distribution pipe up to the first branching.
 - modified to a high differential temperature between the flow pipe and the return pipe (for example district heating).
- Underfloor heating systems with thermostatic valves.
- One-pipe heating systems with thermostatic valves or pipe balancing valves.
- Primary circuit pumps in systems with small pressure losses in the primary circuit.

Characteristics and key benefits

- The pump pressure is kept constant, independent of the flow in the system.

Technical specifications

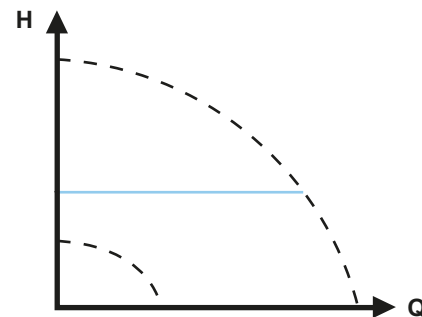

Fig. 19 Constant-pressure control

TM05 2449 0312

Constant temperature

This control mode is suitable in heating systems with a fixed system characteristic, for example domestic hot-water systems, where the control of the pump according to a constant return-pipe temperature is relevant.

Characteristics and key benefits

- The temperature is kept constant.
- $FLOW_{LIMIT}$ is used to control the maximum circulation flow rate.

Technical specifications

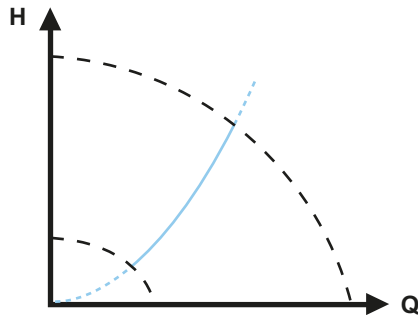

Fig. 20 Constant-temperature control

The inverse control for cooling application is available from model B.

Temperature sensor

If the pump is installed in the flow pipe, install an external temperature sensor in the return pipe of the system. See fig. 21. Install the sensor as close as possible to the consumer (radiator, heat exchanger, etc.).

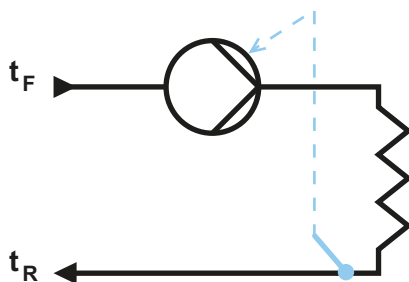

Fig. 21 Pump with an external sensor

If the pump is installed in the return pipe of the system, you can use the internal temperature sensor. In this case, install the pump as close as possible to the consumer (radiator, heat exchanger, etc.).

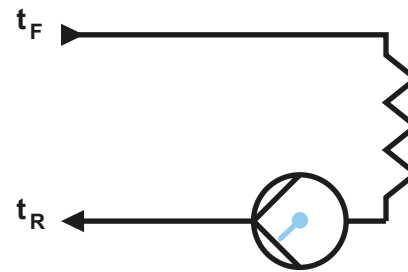

Fig. 22 Pump with an internal sensor

Differential temperature

Select this control mode if the pump performance is to be controlled according to a differential temperature in the system where the pump is installed.

Characteristics and key benefits

- Ensures a constant differential temperature drop across heating and cooling systems.
- Ensures a constant differential temperature between the pump and the external sensor, see figs 23 and 24.
- Requires two temperature sensors, the internal temperature sensor together with an external sensor.

Technical specifications

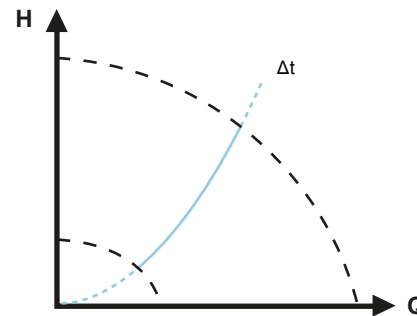

Fig. 23 Differential temperature

Temperature sensor

To measure the temperature difference of the flow pipe and the return pipe, you must use both the internal sensor and an external sensor. If the pump is installed in the flow pipe, the external sensor must be installed in the return pipe and vice versa. Always install the sensor as close as possible to the consumer (radiator, heat exchanger, etc.). See fig. 24.

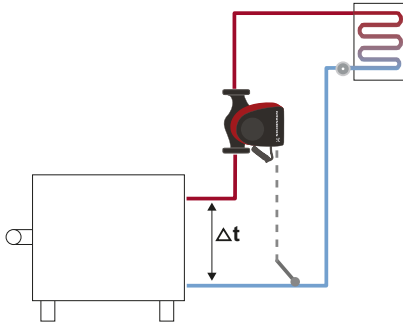

Fig. 24 Differential temperature

Constant curve

A constant curve is suitable for systems, where both a constant flow rate and a constant head are required, i.e.:

- Heat surfaces
- cooling surfaces
- heating systems with 3-way valves
- air condition system with 3-way-valve
- chiller pumps

Characteristics and key benefits

- If an external controller is installed, the pump is able to change from one constant curve to another, depending on the value of the external signal.
- Depending on your preferences, the pump can be controlled according to either a maximum or minimum curve.

Technical specifications

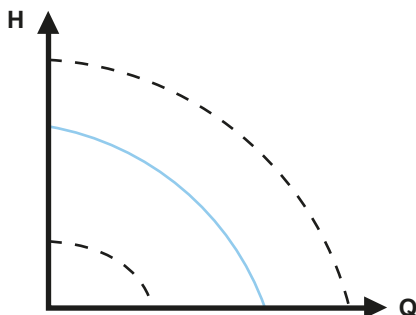

Fig. 25 Constant-curve duty

The pump can be set to operate according to a constant curve, like an uncontrolled pump. See fig. 25.

Depending on the pump model, you can set the desired speed in % of the maximum speed. The span of control depends on the minimum speed, power and pressure limitation of the pump.

Note: If the pump speed is set in the range between minimum and maximum, the power and pressure are limited when the pump is running on the maximum curve. This means that the maximum performance can be achieved at a speed lower than 100 %. See fig. 26.

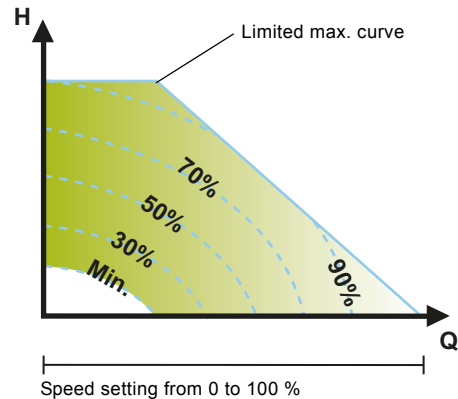

Fig. 26 Power and pressure limitations influencing the maximum curve

You can also set the pump to operate according to the maximum or minimum curve, like an uncontrolled pump:

- You can use the maximum curve mode in periods where a maximum flow rate is required. This operating mode is for instance suitable for hot-water priority.
- You can use the minimum curve mode in periods where a minimum flow rate is required. This operating mode is for instance suitable for manual night setback if automatic night setback is not desired.

You can select these two operating modes via the digital inputs.

In the control mode constant curve, you can obtain a constant flow by choosing a setpoint at 100 % and choosing the desired value for the flow rate with the $FLOW_{LIMIT}$ function. Take the accuracy of the flow rate estimation into consideration.

Additional control mode features

MAGNA3 offers additional features for the control modes to meet specific demands.

FLOW_{LIMIT}

The feature is an integrated part of the FLOW_{ADAPT} control mode, but is also advantageous in:

- proportional-pressure mode
- constant-pressure mode
- constant-temperature mode
- constant-curve mode.

Characteristics and key benefits

- A control mode feature that, when activated, ensures that the rated maximum flow is never exceeded.
- By enabling FLOW_{LIMIT} in systems where MAGNA3 has full authority, the rated flow is never exceeded, thus eliminating the need for throttling valves.

Technical specifications

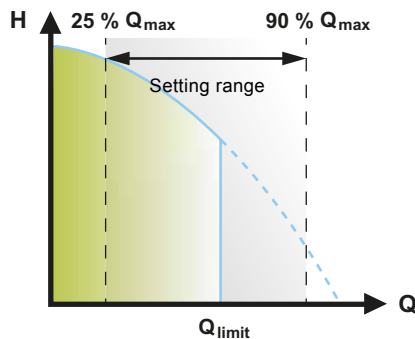

Fig. 27 FLOW_{LIMIT}

The setting range for the FLOW_{LIMIT} is 25 to 90 % of the Q_{max} of the pump.

Note: Do not set the FLOW_{LIMIT} lower than the dimensioned duty point.

In the flow rate range between 0 and Q_{limit} , the pump will run according to the selected control mode.

TM05 2445 1312

When Q_{limit} is reached, the FLOW_{LIMIT} function will reduce the pump speed to ensure that the flow rate never exceeds the FLOW_{LIMIT} set, no matter if the system requires a higher flow rate due to an increased resistance in the system. See figs 28, 29 and 30.

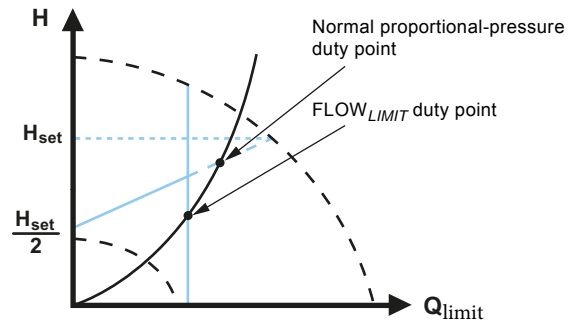

Fig. 28 Proportional-pressure control with FLOW_{LIMIT}

TM05 2543 0412

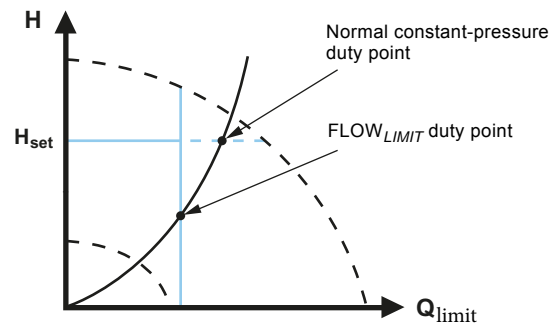

Fig. 29 Constant-pressure control with FLOW_{LIMIT}

TM05 2444 0312

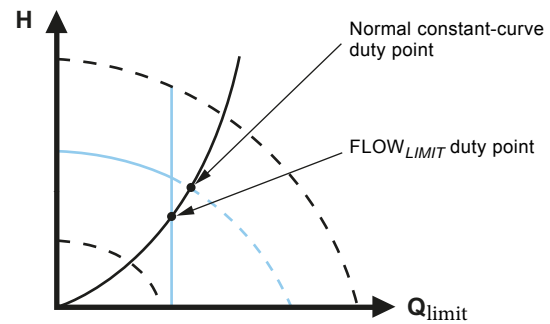

Fig. 30 Constant curve with FLOW_{LIMIT}

TM05 2542 0412

Automatic night setback

A night setback system is often integrated into a building management system (BMS), or as part of an equivalent electronic control system, which has a built-in timer.

The feature is not beneficial in rooms with underfloor heating because of the regulating inertia of the underfloor heating.

Characteristics and key benefits

- Automatic night setback lowers the room temperature at night, which reduces heating costs.
- The pump automatically changes between normal duty and night setback (duty at low demand), depending on the flow pipe temperature.
- Once activated, the pump runs on the minimum curve.

Technical specifications

The pump automatically changes to night setback when the built-in sensor registers a flow-pipe temperature drop of more than 18 to 27 °F (10 to 15 °C) within approximately two hours. The temperature drop must be at least 0.18 °F/min (0.1 °C/min).

Changeover to normal duty takes place without time lag when the temperature has increased by approximately 18 °F (10 °C).

Note: You cannot enable automatic night setback when the pump is in constant-curve mode.

Multipump modes

Multipump function

The multipump function enables control of single-head pumps connected in parallel and twin-head pumps without the use of external controllers. The pumps in a multipump system communicate with each other via the wireless GENIair connection.

Pump system:

- Twin-head pump.
- Two single-head pumps connected in parallel. The pumps must be of equal size and type. Each pump requires a non-return valve in series with the pump.

A multipump system is set via a selected pump, i.e. the master pump (first selected pump). The multipump functions are described in the following sections.

Alternating operation

Only one pump is operating at a time. The change from one pump to the other depends on time or energy. If a pump fails, the other pump will take over automatically.

Backup operation

One pump is operating continuously. The backup pump is operated at intervals to prevent seizing up. If the duty pump stops due to a fault, the backup pump will start automatically.

Cascade operation

Cascade operation ensures that the pump performance is automatically adapted to the consumption by switching pumps on or off. The system thus runs as energy-efficiently as possible with a constant pressure and a limited number of pumps.

The slave pump will start when the master pump is running at maximum or has a fault, and it will stop again when the master pump is running below 50 %.

Cascade operation is available in constant speed and constant pressure. You can with advantage choose a twin-head pump as the backup pump will start for a short period in peak-load situations.

All pumps in operation will run at equal speed. Pump changeover is automatic and depends on speed, operating hours and faults.

Flow estimation accuracy

The internal sensor estimates the difference in pressure between the inlet and outlet port of the pump. The measurement is not a direct differential-pressure measurement, but by knowing the hydraulic design of the pump, you can estimate the differential pressure across the pump. The speed and power are also used to give a direct estimation of the current duty point of the pump.

The calculated flow rate has an accuracy specified as $\pm xx\%$ of Q_{\max} . The less flow through the pump, the less accurate the reading will be. The typical accuracy of the flow reading is $\pm 5\%$ of the specific pump's maximum flow. In extreme cases, such as closed valve operation, the accuracy can be up to $\pm 10\%$ of the maximum flow.

See also [Heat energy monitor](#), page 26.

Example:

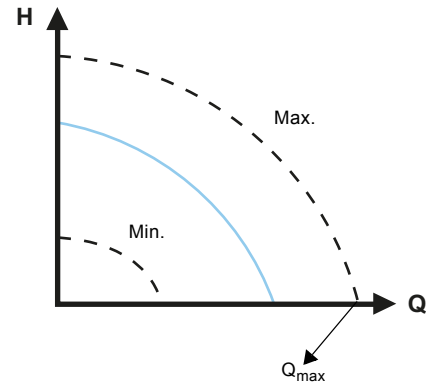

TM05 2448 5111

Fig. 31 Q_{\max}

1. MAGNA3 65-60 has a Q_{\max} of $40 \text{ m}^3/\text{h}$. A typical 5% accuracy means $2 \text{ m}^3/\text{h}$ inaccuracy of Q_{\max} . $\pm 2 \text{ m}^3/\text{h}$.
2. This accuracy is valid for the entire QH area. If the pump indicates $10 \text{ m}^3/\text{h}$, the measurement is $10 \pm 2 \text{ m}^3/\text{h}$.
3. The flow rate can be $8\text{-}12 \text{ m}^3/\text{h}$.
4. **Note:** Use of a water/ethylene glycol mixture will decrease the accuracy.

Readings and settings on the pump

Operating panel and display

The MAGNA3 pump features a 4-in. TFT display with intuitive and user-friendly interface. The operating panel has self-explanatory push-buttons made of high-quality silicone for precise navigation in the menu structure. The operating panel is designed to give the user quick and easy access to pump and performance data on site.

Startup guide and assistance

When you start up the pump for the first time, you are presented with a startup guide enabling easy setting of the pump. Additionally, the Assist menu can guide you through the various settings of the pump.



Fig. 32 Operating panel

Button	Function
	Goes to the Home menu.
	Returns to the previous action.
	Navigates between main menus, displays and digits. When the menu is changed, the display will always show the top display of the new menu.
	Navigates between submenus.
	Saves changed values, resets alarms and expands the value field.

Setting the pump

The MAGNA3 pump range allows you to set the pump directly on the operating panel. The menu includes all available MAGNA3 pump settings such as control mode, setpoint, relay output and bus communication.

Monitoring the pump

Performance overview

The home menu allows you to quickly gain an overview of the main settings of up to four user-defined parameters or view a graphical illustration of a QH performance curve.

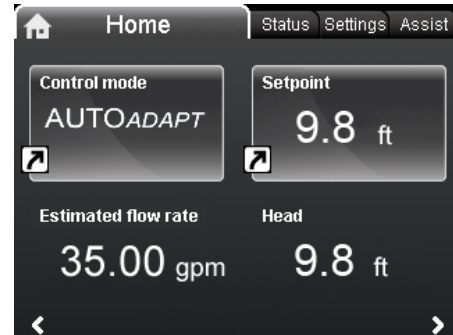

Fig. 33 Example of Home menu with overview of settings and performance

Operating status and pump performance

The status menu shows the current operating mode and the selected control mode, if any. Here, you can also review the performance of the pump:

- QH graph showing current duty point, flow rate, head, power and liquid temperature.
- "Resulting setpoint" showing the setpoint set on the pump, the external influence and the resulting setpoint.
- Liquid temperature.
- Speed.
- Operating hours.

Warning and alarm

The Warning and alarm menu provides information on:

- actual warning or alarm, if any
- information about when the warning or alarm occurred, disappeared and about corrective actions
- Warning and alarm logs.

TM05 7642 1313

undef-010_HOME_us

Heat energy monitor

Heat energy monitor is a monitoring function which makes it possible to track the heat energy distribution and consumption within a system. This prevents excessive energy costs caused by system imbalances. The calculated flow rate has an accuracy specified as $\pm xx\%$ of Q_{\max} . The lower the flow through the pump is, the less accurate the reading will be. Furthermore, the temperature measurements needed for the calculation is also associated with some inaccuracy, depending on the sensor type. Therefore, you cannot use the heat energy value for billing purposes. However, the value is perfect for optimization purposes in order to prevent excessive energy costs caused by system imbalances. See also [Readings and settings on the pump](#), page 25.

The pump requires a temperature sensor in the flow pipe or the return pipe. This temperature sensor is not supplied with the pump.

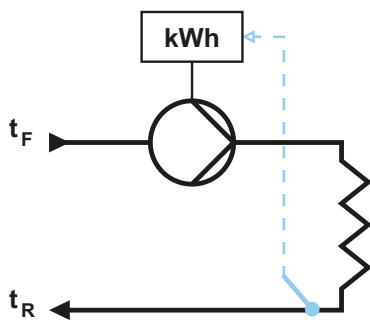

TM05 5367 3612

Fig. 34 MAGNA3 with built-in heat energy monitor

Note: MAGNA3 incorporates a calculator for flow and media temperature, see [External Grundfos sensors](#), page 59.

Operating log

The Operating log is the perfect tool for pump optimization, replacement and fault finding as it offers the following:

- All duty points and operating conditions are tracked and stored in the pump.
- The 3D work log and duty curve (over time) provide instant overviews of historical pump performance and operating conditions.

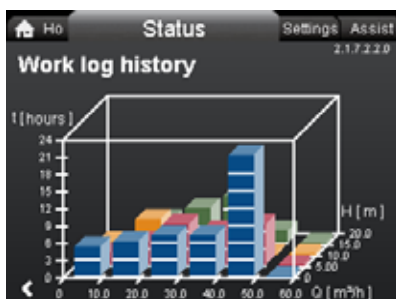

Fig. 35 Example of Operating log

Help and guidance

The Assist menu guides you through the setup of the pump and offers the following:

- step-by-step instructions in how to set the pump
- a short description of the six control modes and recommended applications
- assistance with fault correction
- fault advice
- multipump setup
- setup, analog input
- description of control mode.

Grundfos Eye

Grundfos Eye at the top of the operating panel is a pump status indicator light providing information about the pump operating status.

The indicator light will flash in different sequences and provide information about the following:

- power on or off
- pump warnings
- pump alarms
- remote control
- pump running or stopped.

The function of Grundfos Eye is described in detail in the installation and operating instructions.



Fig. 36 Grundfos Eye

TM05 3810 1612

Communication

MAGNA3 enables communication via the following:

- wireless Grundfos GO
- fieldbus communication via CIM modules
- digital inputs
- relay outputs
- analog input.

Grundfos GO



TM05 3825 2017

Fig. 37 Grundfos GO

With Grundfos GO, you can monitor your pump, change settings, collect data and make reports. A user-friendly interface provides you with all the information and help you need, as well as live pump data monitoring and easy-to-follow tips and guides. You can use Grundfos GO for the following functions:

- reading of operating data
- reading of warning and alarm indications
- setting of control mode
- setting of setpoint
- selection of external setpoint signal
- allocation of pump number making it possible to distinguish between pumps that are connected via Grundfos GENIbus
- selection of function for digital input
- generation of reports (PDF)
- assist function
- multipump setup
- displaying relevant documentation.

For further details, see [Grundfos GO](#), page 58.

Wireless GENIair

The pump is designed for multipump connection via the wireless GENIair connection.

The built-in wireless GENIair module enables communication between pumps and with Grundfos GO without the use of add-on modules:

- Multipump function.
See [Multipump function](#), page 23.
- Grundfos GO.
See [Grundfos GO](#), page 58.

CIM modules







TM05 3811 1612

Fig. 38 Grundfos CIM modules

A CIM module is an add-on Communication Interface Module. The CIM module enables data transmission between the pump and an external system, for example a BMS (Building Management System) or SCADA system.

The CIM module communicates via fieldbus protocols. See [Available CIM modules](#), page 28.

Available CIM modules

Module	Fieldbus protocol	Description	Functions
<p>CIM 050</p> 	<p>GENIbus</p> <p>TM06 7238 3416</p>	<p>CIM 050 is a Grundfos communication interface module used for communication with a GENIbus network.</p>	<p>CIM 050 has terminals for the GENIbus connection.</p>
<p>CIM 100</p> 	<p>LonWorks</p> <p>TM06 7279 3416</p>	<p>CIM 100 is a Grundfos communication interface module used for communication with a LonWorks network.</p>	<p>CIM 100 has terminals for the LonWorks connection.</p> <p>Two LEDs are used to indicate the actual status of the CIM 100 communication.</p> <p>One LED is used for indication of correct connection to the pump, and the other is used to indicate LonWorks communication status.</p>
<p>CIM 200</p> 	<p>Modbus RTU</p> <p>TM06 7281 3416</p>	<p>CIM 200 is a Grundfos communication interface module used for communication with a Modbus RTU network.</p>	<p>CIM 200 has terminals for the Modbus connection.</p> <p>DIP switches are used to select parity and stop bits, to select transmission speed and to set line termination.</p> <p>Two hexadecimal rotary switches are used to set the Modbus address.</p> <p>Two LEDs are used to indicate the actual status of the CIM 200 communication.</p> <p>One LED is used for indication of correct connection to the pump, and the other is used to indicate Modbus communication status.</p>
<p>CIM 300</p> 	<p>BACnet MS/TP</p> <p>TM06 7281 3416</p>	<p>CIM 300 is a Grundfos communication interface module used for communication with a BACnet MS/TP network.</p>	<p>CIM 300 has terminals for the BACnet MS/TP connection.</p> <p>DIP switches are used to set transmission speed and line termination and to select the custom Device Object Instance Number.</p> <p>Two hexadecimal rotary switches are used to set the BACnet address.</p> <p>Two LEDs are used to indicate the actual status of the CIM 300 communication.</p> <p>One LED is used for indication of correct connection to the pump, and the other is used to indicate BACnet communication status.</p>
<p>CIM 500</p> 	<p>Ethernet</p> <p>TM06 7283 3416</p>	<p>CIM 500 is a Grundfos communication interface module used for data transmission between an industrial Ethernet network and a Grundfos product. CIM 500 supports various industrial Ethernet protocols:</p> <ul style="list-style-type: none"> • PROFINET • Modbus TCP • BACnet/IP • Ethernet/IP 	<p>CIM 500 supports various industrial Ethernet protocols. CIM 500 is configured via the built-in web server, using a standard web browser on a PC.</p> <p>See the specific functional profile on the DVD-ROM supplied with the Grundfos CIM module.</p>

For product numbers, see [CIM modules](#), page 57.

Digital inputs

You can use the digital input for external control of start or stop or forced maximum or minimum curve.

Note: If no external on and off switch is connected, maintain the jumper between the Start/Stop (S/S) and frame (⊥) terminals. This connection is the factory setting.

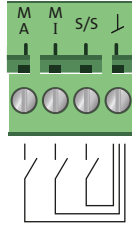

Fig. 39 Digital input in control box

TM05 3343 1212

Contact symbol	Function
M/A	Maximum curve
M/I	Minimum curve
S/S	Start/Stop
⊥	Frame connection

External start or stop

You can start and stop the pump via the digital input.

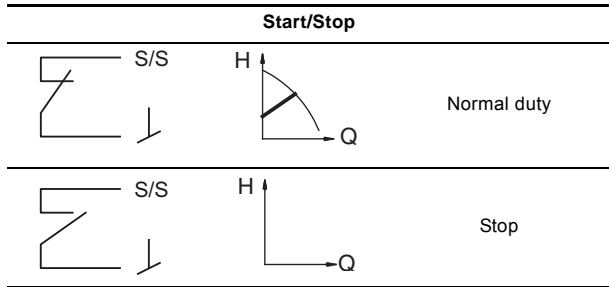

External forced maximum or minimum curve

You can force the pump to operate on the maximum or minimum curve via the digital input.

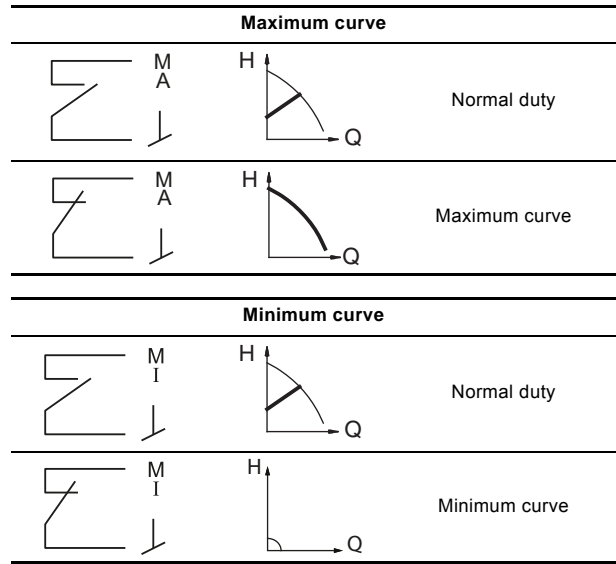

Relay outputs

The pump has two signal relays with a potential-free changeover contact for external fault indication.

You can set the function of the signal relay to Alarm, Ready or Operation on the pump operating panel or with Grundfos GO.

Factory settings of relays:

Relay	Function
1	Operation signal
2	Alarm signal

Note: You can configure both relays to "ready, alarm or operating".

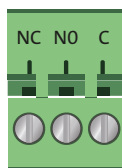

Fig. 40 Relay output in the control box

TM05 3343 1212

Contact symbol	Function
NC	Normally closed
NO	Normally open
C	Common

The functions of the signal relays are as shown in the table below:

Signal relay Alarm signal



Not activated:

- The power supply has been switched off.
- The pump has not registered a fault.



Activated:

- The pump has registered a fault.

Signal relay Ready signal



Not activated:

- The pump has registered a fault and is unable to run.



Activated:

- The pump has been set to stop, but is ready to run.
- The pump is running.

Signal relay Operating signal



Not activated:

- The pump is not running.



Activated:

- The pump is running.

Analog input for an external sensor

To optimize pump performance, you can use the analog input for the connection of an external sensor in the following cases:

Function/control mode	Sensor type
Heat energy monitor	Temperature sensor
Constant temperature	
Constant pressure	Differential-pressure transmitter

When using an external differential-pressure sensor to control the flow in the system, you obtain the externally set pressure, which results in the following benefits:

- minimizes operating costs
- prevents valve noise
- ensures comfort (adequate pressure).

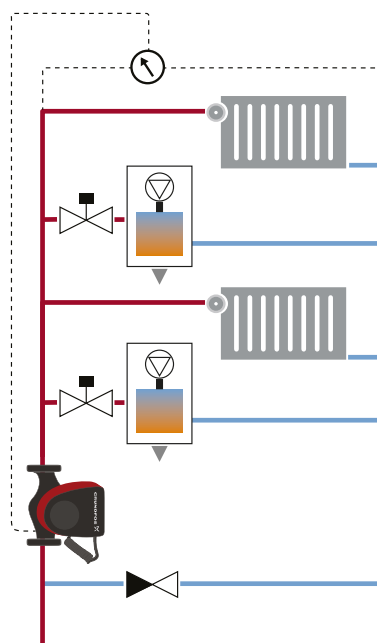

Fig. 41 External differential-pressure sensor

TM06 3255 5014

The electrical signal for the input can be 0-10 V or 4-20 mA. You can change the selection of the electrical signal (0-10 V or 4-20 mA) on the operating panel or with Grundfos GO.

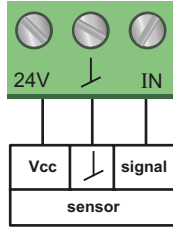

Fig. 42 Analog input for an external sensor or control

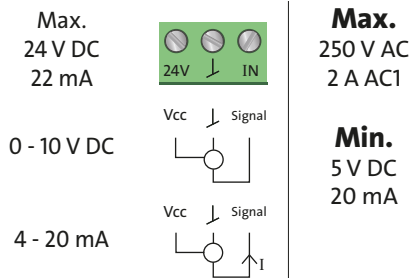

Fig. 43 Wiring, analog input

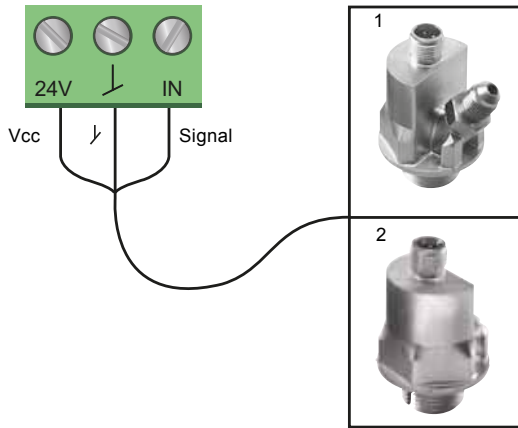

Fig. 44 Examples of external sensors

Pos.	Sensor type
1	Differential-pressure transmitter, Grundfos type DPI V.2 1/2" connection and 4-20 mA signal.
2	Relative-pressure transmitter. Combined temperature and pressure sensor, Grundfos type RPI T2. 1/2" connection and 0-10 V signal.

For further details, see [External Grundfos sensors](#), page 59.

External control system

The analog input can be used for an external signal for the control from a BMS system or similar control system.

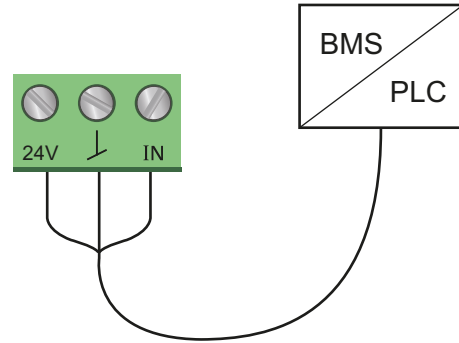

Fig. 45 Example of an external signal for the control via BMS or PLC

External setpoint function

You can use the analog input to influence the setpoint externally. Here, a 0-10 V or 4-20 mA signal controls the pump speed range in a linear function. The range of control depends on the minimum speed, power and pressure limits of the pump. See figs 46 and 47.

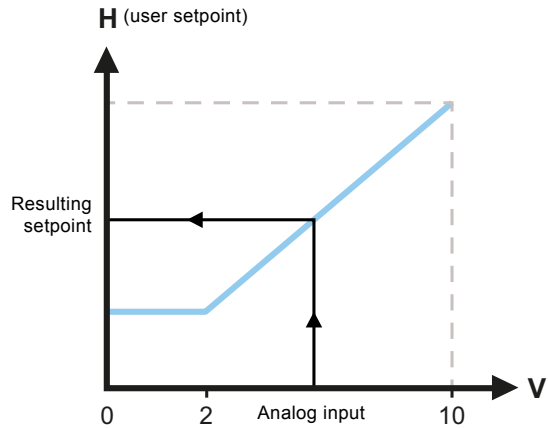

Fig. 46 External setpoint function, 0-10 V

Control	
0-2 V (0-20 %)	Resulting setpoint is equal to minimum.
2-10 V (20-100 %)	Resulting setpoint is between minimum and user setpoint.

Fig. 47 Control range and setpoint

The external setpoint function operates differently, depending on the model. For model A,B and C, the maximum speed is often obtained at voltages lower than 10 V as the span of control is limited.

In models newer than A,B, and C, the internal scaling has been optimized to make the dynamic area bigger, thus giving a better control of the pump speed when using the external setpoint function.

The same applies if the pump is receiving a setpoint from Building Management Systems.

5. Operating conditions

General recommendations

Water in heating systems	Water quality according to local standards such as the German standard VDI 2035
Domestic hot water	Degree of hardness up to 14 °dH
Water containing glycol	Maximum viscosity = 10-50 cSt ~ 50 % water and 50 % ethylene glycol at +14 °F (-10 °C)

Liquid temperature

Application	Temperature range
General	+14 to +230 °F (-10 to +110 °C)
Domestic hot-water systems	Up to 149 °F (65 °C) recommended

Location

The pump is designed for indoor installation.

Always install the pump in an dry environment where it will not be exposed to drops or splashes, for example water, from surrounding equipment or structures.

As the pump contains stainless-steel parts, it is important that it is not installed directly in environments, such as:

- Indoor swimming pools where the pump would be exposed to the ambient environment of the pool.
- Locations with direct and continuous exposure to a marine atmosphere.
- In rooms where hydrochloric acid (HCl) can form acidic aerosols escaping from, for example, open tanks or frequently opened or vented containers.

The above applications do not disqualify for installation of MAGNA3. However, it is important that the pump is not installed directly in these environments.

Ambient conditions

Ambient conditions	
Ambient temperature during operation	32 to 104 °F (0 to 40 °C)
Ambient temperature during storage and transport	-40 to 158 °F (-40 to +70 °C)
Relative humidity	Maximum 95 %

Maximum operating pressure

PN 12: 175 psi (12 bar, 1.2 MPa).

Minimum inlet pressure

The following relative minimum pressure must be available at the pump inlet during operation to avoid cavitation noise and damage to the pump bearings.

The values in the table below apply to single-head pumps and twin-head pumps in single-head operation.

MAGNA3 DN	Liquid temperature		
	[167 °F (75 °C)]	[203 °F (95 °C)]	[230 °F (110 °C)]
	Inlet pressure [psi (bar)]		
32-60/100	1.5 (0.10)	5.0 (0.35)	14.5 (1.0)
40-80/120/180	1.45 (0.10)	7.25 (0.50)	14.50 (1.00)
50-80	1.45 (0.10)	5.80 (0.40)	14.50 (1.00)
50-150	10.15 (0.70)	17.40 (1.20)	24.66 (1.70)
65-120/150	10.15 (0.70)	17.40 (1.20)	24.66 (1.70)
80-100	7.25 (0.50)	14.50 (1.00)	21.76 (1.50)
100-120	10.15 (0.70)	17.40 (1.20)	24.66 (1.70)

In the case of cascade twin-head operation, increase the required relative inlet pressure by 1.45 psi (0.1 bar, 0.01 MPa) compared to the stated values for single-head pumps or twin-head pumps in single-head operation.

Note: The actual inlet pressure plus pump pressure against a closed valve must be lower than the maximum permissible system pressure.

The relative minimum inlet pressures apply to pumps installed up to 984 ft (300 meters) above sea level. For altitudes above 984 ft (300 meters), increase the required relative inlet pressure by 0.145 psi (0.01 bar, 0.001 MPa) per 328 ft (100 meters) altitude. The MAGNA3 pump is only approved for an altitude of 6560 ft (2000 meters).

Pumped liquids

The pump is suitable for thin, clean, non-aggressive and non-explosive liquids, not containing solid particles or fibers that may attack the pump mechanically or chemically.

In heating systems, the water must meet the requirements of accepted standards on water quality in heating systems.

In domestic hot-water systems, we recommend that you use MAGNA3 pumps only for water with a degree of hardness lower than approximately 14 °dH.

In domestic hot-water systems, we recommend that you keep the liquid temperature below 149 °F (65 °C) to eliminate the risk of lime precipitation.

You can use MAGNA3 pumps for pumping water and glycol mixtures up to 50 %.

Example of a water and ethylene glycol mixture:

Maximum viscosity: 10-50 cSt ~ 50 % water and 50 % ethylene glycol mixture at +14 °F (10 °C).

The pump is controlled by a power-limiting function that protects against overload.

The pumping of glycol mixtures will affect the maximum curve and reduce the performance, depending on the water and ethylene glycol mixture and the liquid temperature.

To prevent the ethylene glycol mixture from degrading, avoid temperatures exceeding the rated liquid temperature and minimize the operating time at high temperatures.

You must clean and flush the system before the ethylene glycol mixture is added.

To prevent corrosion or lime precipitation, maintain the ethylene glycol mixture regularly. If further dilution of the supplied ethylene glycol is required, follow the glycol supplier's instructions.

Electrical data

Pump type	MAGNA3 (D)
Enclosure class	Type 2
Insulation class	F.
Supply voltage	1 x 115-230 V ± 10 %, 60 Hz*, PE.
Three digital inputs	External potential-free contact. Contact load: 5 V, 10 mA. Screened cable. Loop resistance: Maximum 130 Ω.
Analog input	4-20 mA (load: 150 Ω). 0-10 VDC (load: > 10 kΩ).
Two relay outputs	Internal potential-free changeover contact. Maximum load: 250 V, 2 A, AC1. Minimum load: 5 VDC, 20 mA. Screened cable, depending on signal level.
Bus input	Grundfos Communication Interface Modules (add-on CIM modules) for: <ul style="list-style-type: none"> • GENibus • LonWorks+ • Modbus RTU • BACnet MS/TP • Ethernet.
Leakage current	$I_{leakage} < 3,5 \text{ mA}$. The leakage currents are measured in accordance with EN 60335-1.
EMC	Standards used: EN 55014-1:2006 + A1:2009 + A2:2011, EN 55014-1:2017, EN 61000-6-2:2005, EN 61000-3-3:2013, EN61000-3-2:2014.
Cos φ	Terminal-connected versions have a built-in active PFC (Power Factor Control) which gives a cos φ from 0.98 to 0.99, i.e. very close to 1. Wire-to-wire versions have no PFC and therefore the power factor is from 0.50 to 0.99.
Consumption when the pump is stopped	4 to 10 W, depending on activity, i.e. reading the display, use of Grundfos GO, interaction with modules, etc. 4 W, when the pump is stopped and there is no activity.

* All MAGNA3 pumps are approved to run on both 50 and 60 Hz.

Sound pressure level

The sound pressure level of the pump is dependent on the power consumption. Levels are determined in accordance with ISO 3745 and ISO 11203, method Q2.

Pump size	Max. dB(A)
32-60/100	39
40-80 50-80	45
40-120/180 50-150 65-120	50
65-150 80-100 100-120	55

6. Construction

MAGNA3 is of the canned-rotor type, i.e. the pump and motor form an integral unit without shaft seal and with only two gaskets for sealing. The bearings are lubricated by the pumped liquid.

The pump is characterized by the following:

- controller integrated in the control box
- operating panel on the control box
- control box prepared for optional CIM modules
- built-in differential-pressure and temperature sensor
- cast-iron or stainless-steel pump housing
- twin-head versions
- no external motor protection required
- insulating shells supplied with single-head pumps for heating systems.

Motor and electronic controller

MAGNA3 incorporates a 4-pole synchronous, permanent-magnet motor (PM motor). This motor type is characterized by higher efficiency than a conventional asynchronous squirrel-cage motor.

The pump speed is controlled by an integrated variable frequency drive.

Differential-pressure and temperature sensor

Sensor specifications, temperature

Temperature range during operation	Accuracy
+14 to +95 °F (-10 to +35 °C)	± 7 °F (± 4 °C)
+95 to +194 °F (+35 to +90 °C)	± 3.5 °F (± 2 °C)
+194 to +230 °F (+90 to +110 °C)	± 7 °F (± 4 °C)

Surface treatment

The pump housing and pump head are electrocoated to improve corrosion resistance.

Electrocoating includes:

- alkaline cleaning
- pretreatment with zinc phosphate coating
- cathodic electrocoating (epoxy)
- curing of paint film at 392 to 482 °F (200 to 250 °C).

The pump housing of stainless-steel versions is not treated or painted and appears in blank steel. See fig. 48.



TM06 0140 4913

Fig. 48 MAGNA3 stainless steel version

Color

Color codes for the pump:

Color	Code
Red	NCS40-50R
Black	NCS9000

Sectional drawing

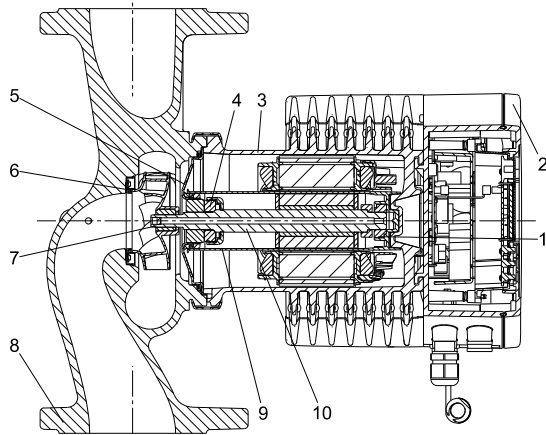

Fig. 49 Terminal-connected version

TM05 2319 0312

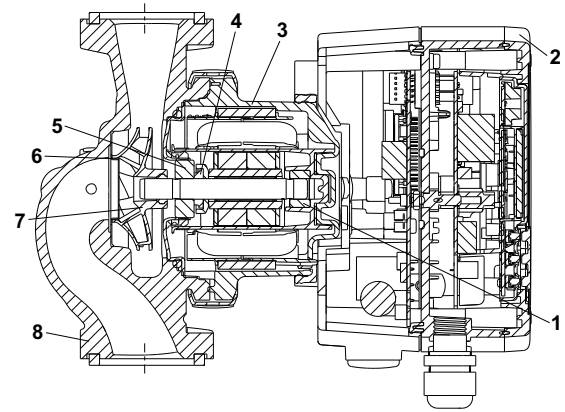

Fig. 50 Wire-to-wire-connected version

TM07 1970 2518

Material specification

See fig. 49.

Pos.	Component	Material	Grade
1	Outer bearing ring	Aluminium oxide	
2	Control box	Polycarbonate	
3	Stator housing	Aluminium	
	O-rings	EPDM	
4	Thrust bearing	Aluminium oxide/carbon	
5	Bearing plate	Stainless steel	AISI 304 (EN 1.4301)
6	Neck ring	Stainless steel	AISI 304 (EN 1.4301)
7	Impeller	PES	
8	Pump housing	Cast iron/stainless steel	ASTM A48 class 35B/AISI 316 (EN 1561 EN-GJL-250/EN 1.4408)
9	Rotor can	PPS	
10	Shaft	Ceramic (wire-to-wire-connected versions)	
10	Shaft	Stainless steel (terminal-connected versions)	AISI 316L (EN 1.4404)

Sensor drawing

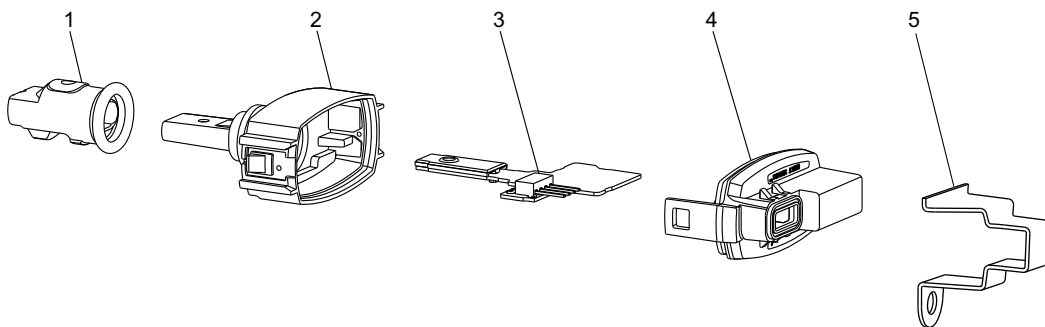

Fig. 51 Sensor

TM06 9250 2117

Pos.	Component	Material	Grade
1	Sealing cap	EPDM	
2	Housing	PPS	
3	Printed-circuit board	-	
4	Cover snap-on	PA/TPV	
5	Bracket for sensor	Stainless steel	AISI 304 (EN 1.4301)

7. Installation

Mechanical installation

MAGNA3 is designed for indoor installation. You must install the pump with horizontal motor shaft. You can install the pump in horizontal as well as vertical pipes.

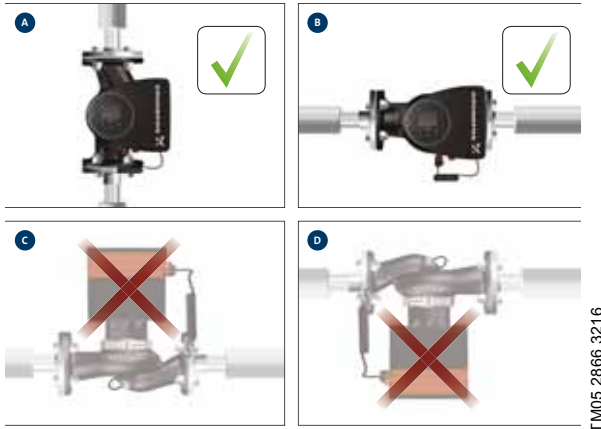

Fig. 52 Installation positions

Arrows on the pump housing indicate the liquid flow direction through the pump.

The control box must be in horizontal position with the Grundfos logo in vertical position. See fig. 52.

You must install the pump in such a way that it is not stressed by the pipes.

The pump may be suspended directly in the pipes, provided that the pipes can support the pump.

Twin-head pumps are prepared for installation on a mounting bracket or base plate.

To ensure adequate cooling of motor and electronics, observe the following:

- Position the pump in such a way that sufficient cooling is ensured.
- The temperature of the ambient air must not exceed 104 °F ° (40 °C).

Insulating shells

The insulating shells supplied with single-head MAGNA3 pumps are for heating systems and must be fitted as part of the installation. **Note:** Insulating shells are not available for twin-head pumps.

Insulating shells increase the pump dimensions.

Electrical installation

The electrical connection and protection must be carried out in accordance with local regulations.

- The pump must be connected to an external main switch.
- The pump must always be correctly grounded.
- The pump requires no external motor protection.
- The pump incorporates thermal protection against slow overloading and blocking.
- When switched on via the power supply, the pump will start pumping after approximately 5 seconds.

Note: The number of starts and stops via the power supply must not exceed four times per hour.

The pump has a digital input that you can use for external control of start/stop without switching the power supply on and off.

Make the pump mains connection as shown in the diagrams on the following pages.

If rigid conduit is to be used, the hub must be connected to the conduit system before it is connected to the terminal box of the pump.

Cables

Use screened cables for the external on and off switch, the digital input, sensor and setpoint signals.

All cables used must be heat-resistant up to at least 167 °F (75 °C.)

All cables used must be installed in accordance with the National Electrical Code, or in Canada, Canadian Electrical Code, and state and local regulations.

Additional protection

Ground fault circuit interrupter (GFCI)

Use a suitable type of GFCI capable of handling ground fault currents with a DC content (pulsating DC). If the pump is connected to an electrical installation where a GFCI is used for additional protection, this GFCI must be able to trip when ground fault currents with DC content occur.

Connection to power supply, terminal-connected versions

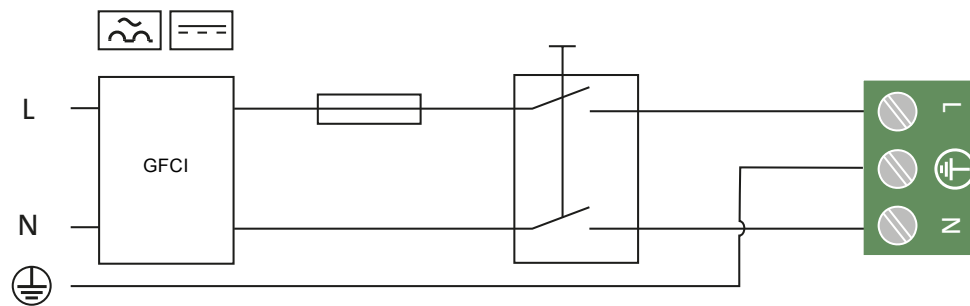

Fig. 53 Example of a terminal-connected motor with main switch, backup fuse and additional protection

TM03 2397 3216

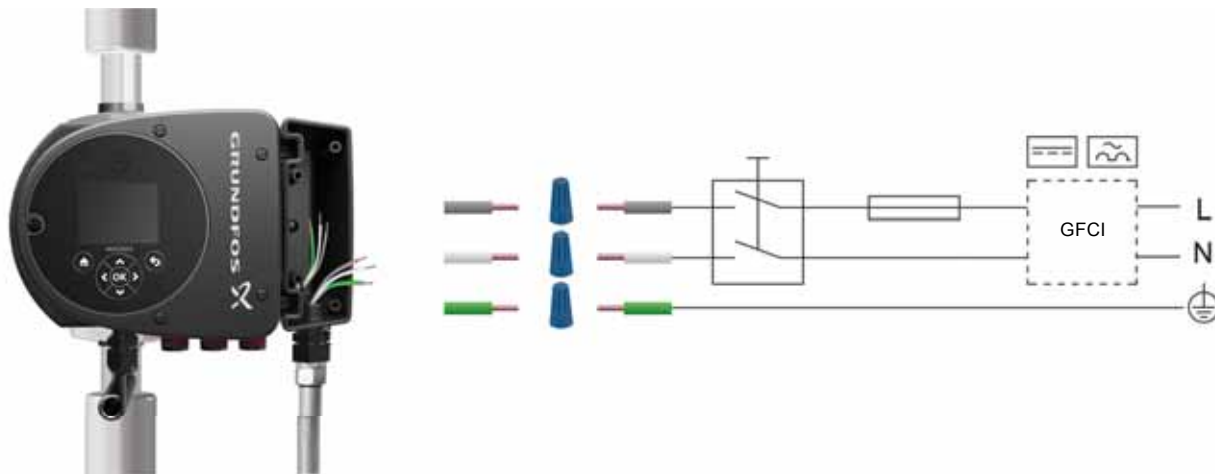

Fig. 54 Example of electrical connections for models with wire-to-wire connections

TM071415 1618

Use a suitable type of GFCI capable of handling ground fault currents with a DC content (pulsating DC). If the pump is connected to an electrical installation where a GFCI is used for additional protection, this GFCI must be able to trip when ground fault currents with DC content occur.

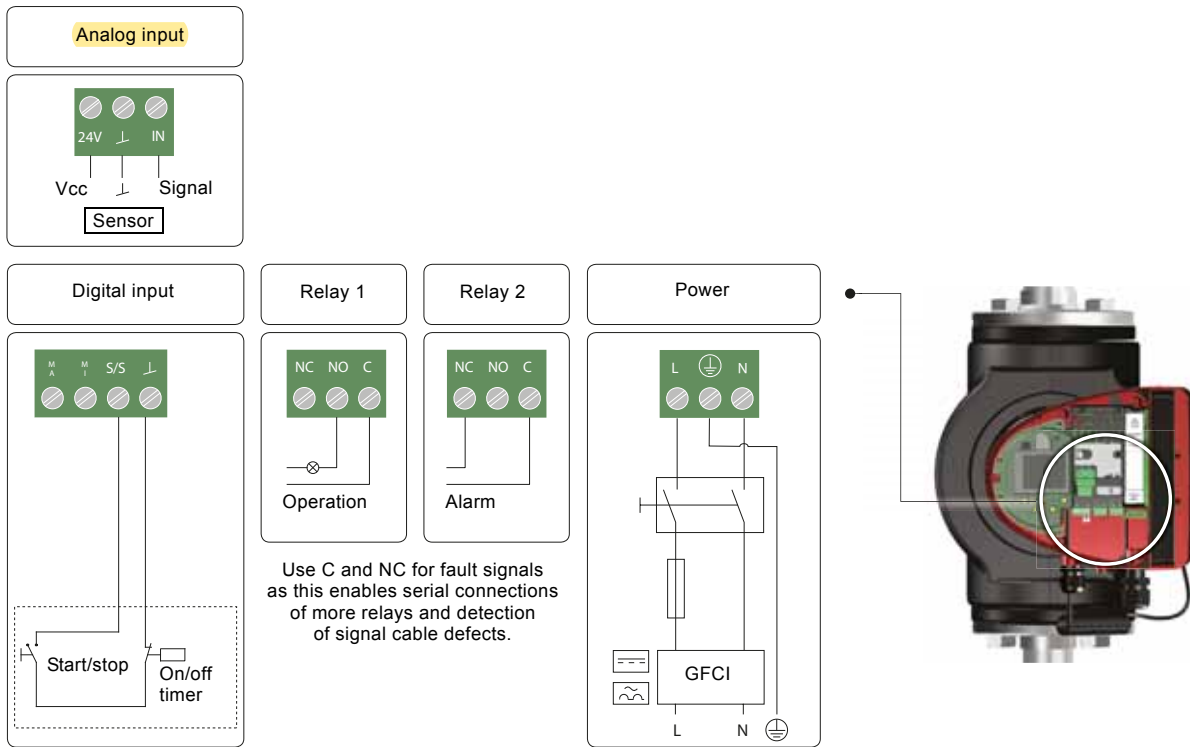

Fig. 55 Example of connections in the control box of terminal-connected versions

TM07 0364 1518

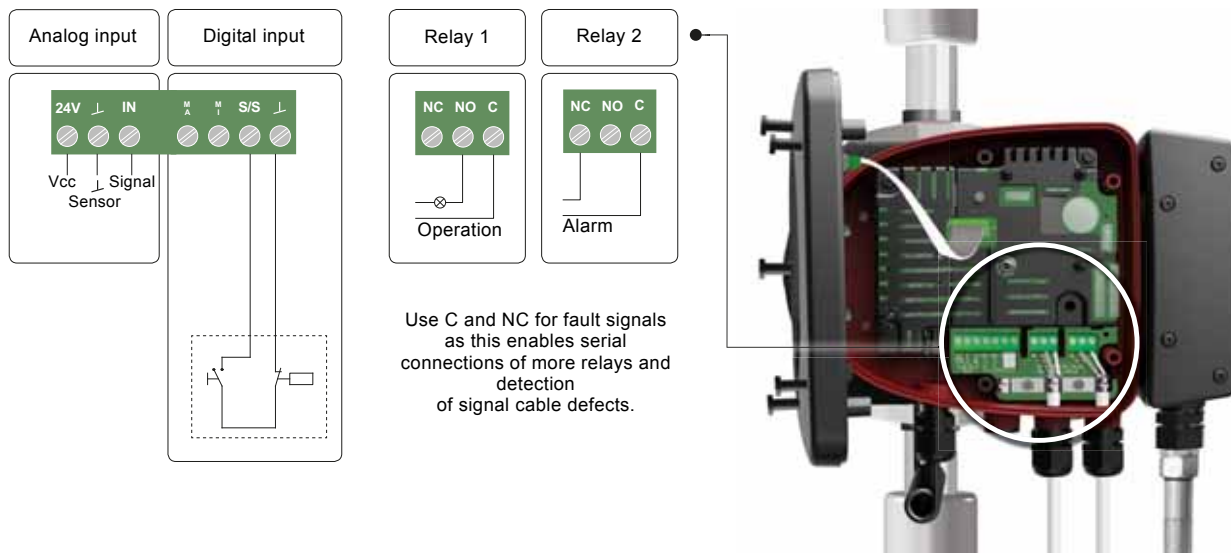

Fig. 56 Example of connections in the control box of wire-to-wire connected versions

TM07 1623 1918

For further information on digital and analog inputs, see [Digital inputs](#), page 29, and [Analog input for an external sensor](#), page 30.

For information on relay outputs, see [Relay outputs](#), page 30.

For details on how to install and operate the MAGNA3 pumps, please see the MAGNA3 model D - Installation and operating instructions:



net.grundfos.com/qr/i/99332342

8. Curve conditions

Performance curves

The guidelines below apply to the performance curves on pages 42 to 56:

- Test liquid: airless water.
- The curves apply to a density of $\rho = 983.2 \text{ kg/m}^3$ and a liquid temperature of 140 °F (60 °C).
- All curves show average values. If a specific minimum performance is required, individual measurements must be made.
- The curves apply to a kinematic viscosity of $\mu = 0.474 \text{ mm}^2/\text{s}$ (0.474 cSt).
- Reference supply voltage: 1 x 230 V, 50 Hz.
- EEI obtained according to EN 16297.

Note: Within the MAGNA3 performance range, you can set the constant- and proportional-pressure curves in steps of 0.1 m head on the operating panel or with Grundfos GO.

Energy efficiency index (EEI)

MAGNA3 is energy-optimized and complies with the EuP Directive (Commission Regulation (EC) No 641/2009) which has been effective as from 1 January 2013.

For MAGNA3 pumps, the average energy efficiency index (EEI) is 0.18 with values down to 0.17, categorized as best in class.

MAGNA3 with its AUTO_{ADAPT} function is the preferred choice for large heating systems and a true efficiency frontrunner.

Figure 57 shows the energy consumption index for a typical circulator pump compared to the various EEI limits.

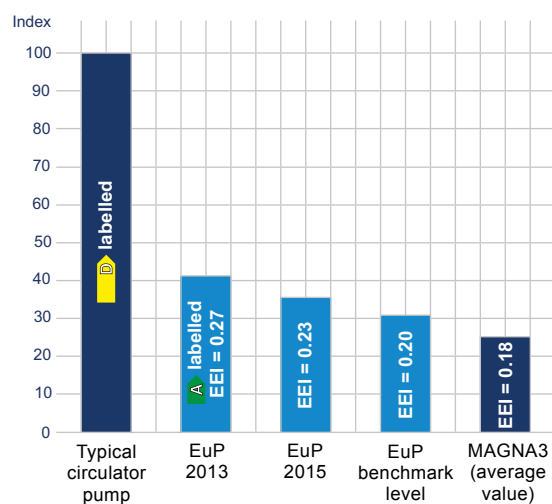

Fig. 57 Energy consumption index, single pumps

With an energy efficiency index (EEI) well below the EuP benchmark level, you can achieve energy savings of up to 75 % compared to a typical circulator pump and thus a remarkably fast return on investment.

QR code on the pump nameplate



TM05 3826 2017



Fig. 58 QR code on the pump nameplate

With Grundfos GO or a smartphone, you get the following information about MAGNA3:

- product photo
- pump performance curves
- dimensional sketches
- wiring diagram
- quotation text
- technical data
- service parts list
- PDF files, such as data booklet and installation and operating instructions.

Markings and approvals

The following marks are available after positive testing of MAGNA3:

Mark	Description
	Intertek - ETL Listed for USA and Canada Conforms to ANSI/UL Std. 778 Certified to CAN/CSA C22.2 No. 108 Motor Operated Water Pumps Liquid Pumps
	USA and Canada Applies to pumps with stainless steel pump housing (flange).

9. Performance curves and technical data

Conversion tables

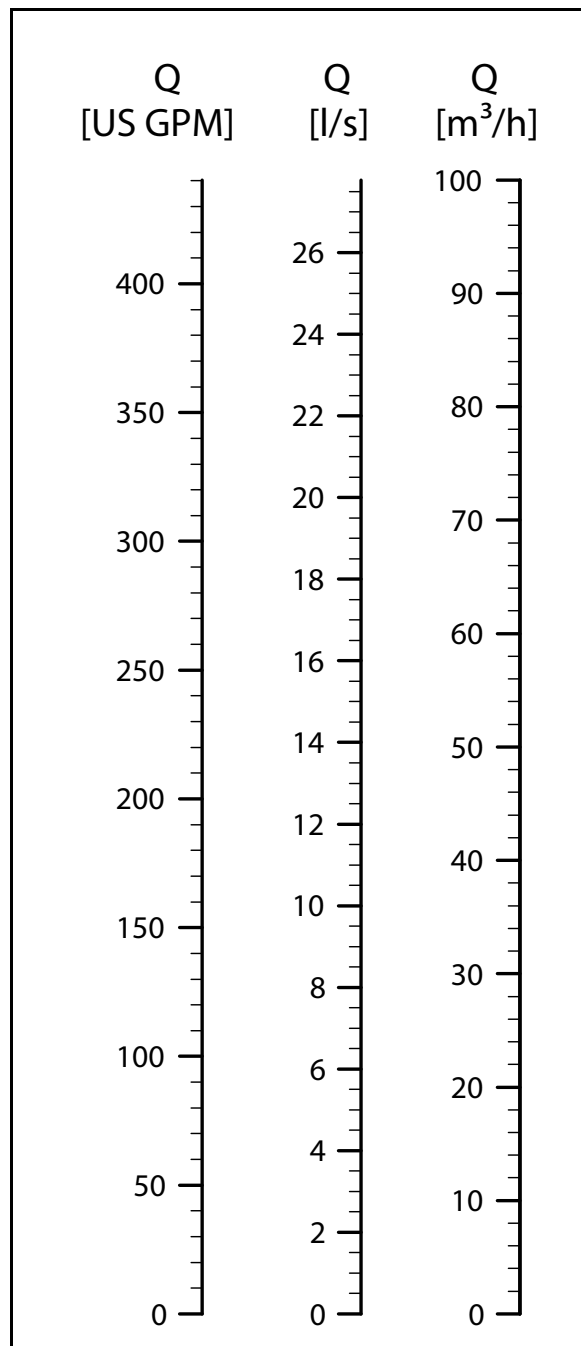
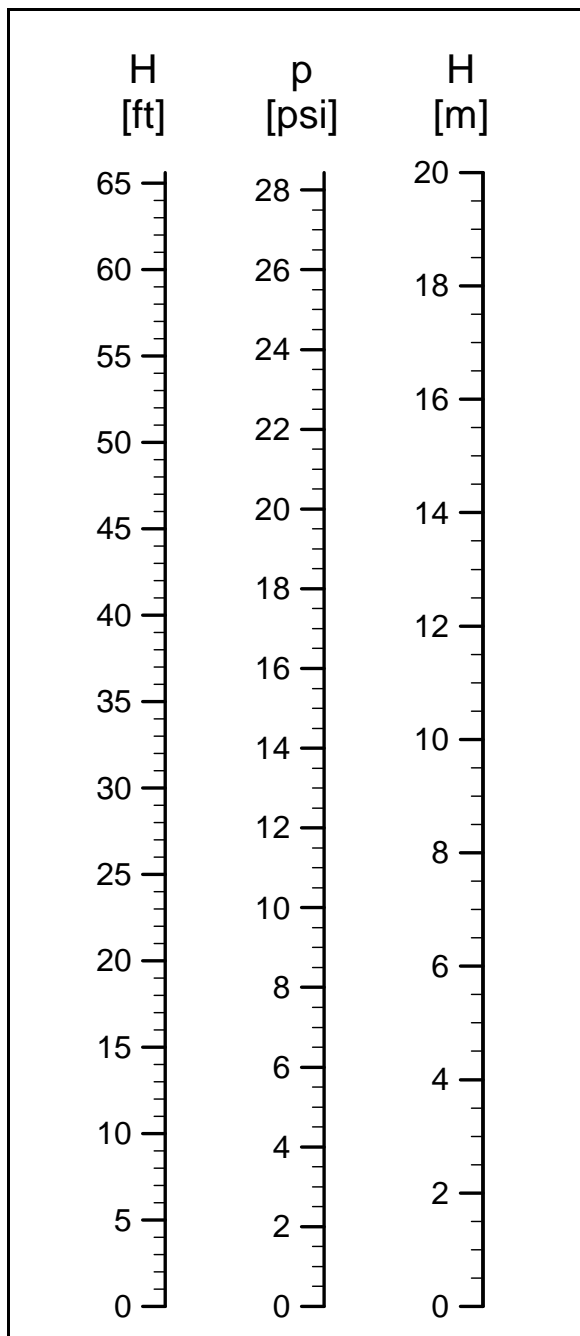

MAGNA3 32-60 F (N)

1 x 115, 230 V, 60 Hz

Proportional pressure

Constant pressure

0-10 volts*

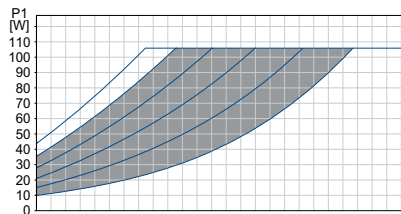
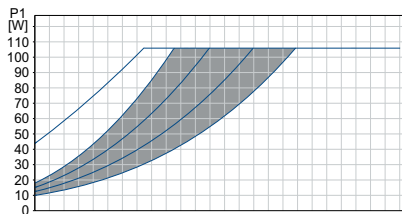
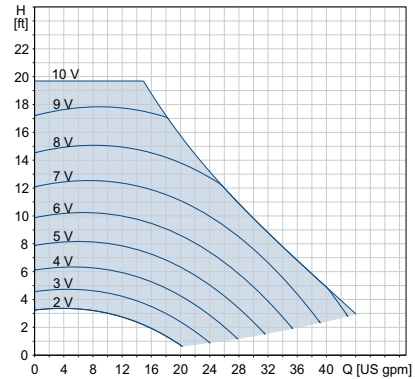
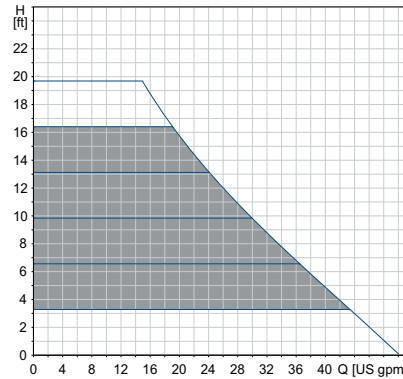
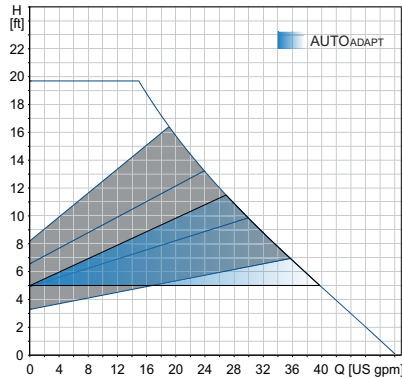

Speed	P1 [W] 115 V	I ₁ [A] 115 V	P1 [W] 230 V	I ₁ [A] 230 V
Min.	8.5	0.28	9	0.09
Max.	106	1.01	106	0.91

* External setpoint influence shown with a setpoint of H_{max}

The pump incorporates overload protection.

- Connections: GF15/26/40/43 flanges. See [Pipe connections](#), page 61.
- System pressure: Max. 175 psi (1.2 MPa) (12 bar).
- Liquid temperature: 14 to 230 °F (-10 to +110 °C) (TF 110).
- Also available with: Stainless-steel pump housing, type N.
- Specific EEI: 0.20 (115 V)
0.19 (230 V)

Model	Net weights [lb (kg)]	Ship. vol. [ft ³ (m ³)]
32-60	13.2 (6.0)	0.76 (0.03)
32-100	13.9 (6.3)	

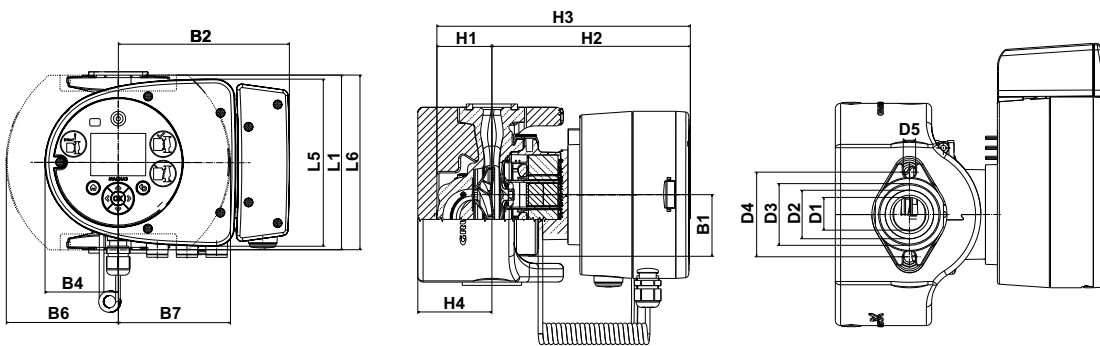

TM07 1509 1518

Pump type	Dimensions [inches (mm)]								
	L1	L5	L6	B1	B2	B4	B6	B7	D1
MAGNA3 32-60 F (N)	6.50 (165)	6.23 (158)	6.62 (168)	2.29 (58)	6.39 (162)	2.72 (69)	4.18 (106)	4.18 (106)	1.26 (32)
	D2	D3	D4	D5	H1	H2	H3	H4	
	1.82 (46)	2.29 (58)	3.15 (80)	0.46 (11.5)	2.13 (54)	7.37 (187)	9.49 (241)	2.76 (70)	

For product numbers, see page 62.

MAGNA3 32-100 F (N)

1 x 115, 230 V, 60 Hz

Proportional pressure

Constant pressure

0-10 volts*

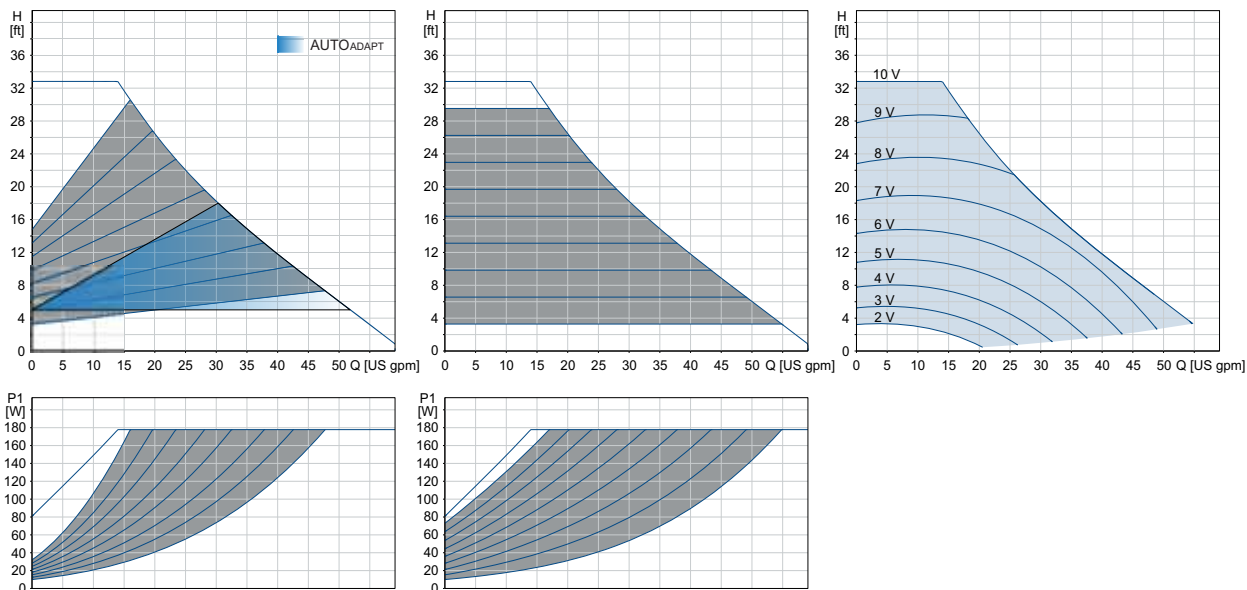

Speed	P1 [W] 115 V	I ₁ [A] 115 V	P1 [W] 230 V	I ₁ [A] 230 V
Min.	9.7	0.29	9	0.09
Max.	178	1.61	178	1.47

The pump incorporates overload protection.

Model	Net weights [lb (kg)]	Ship. vol. [ft ³ (m ³)]
32-60	13.2 (6.0)	0.76 (0.03)
32-100	13.9 (6.3)	

* External setpoint influence shown with a setpoint of H_{max}

- Connections: GF15/26/40/43 flanges. See [Pipe connections](#), page 61.
- System pressure: Max. 175 psi (1.2 MPa) (12 bar).
- Liquid temperature: 14 to 230 °F (-10 to +110 °C) (TF 110).
- Also available with: Stainless-steel pump housing, type N.
- Specific EEI: 0.20 (115 V)
0.19 (230 V)

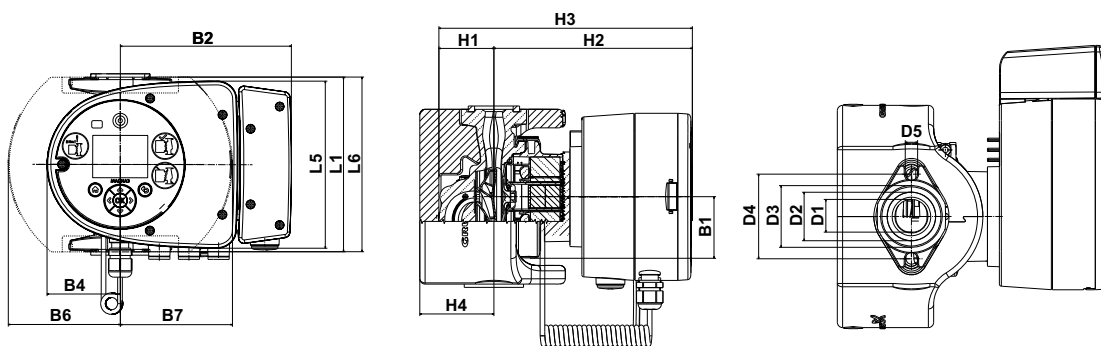

TM07 1509 1518

Pump type	Dimensions [inches (mm)]								
	L1	L5	L6	B1	B2	B4	B6	B7	D1
MAGNA3 32-60 F (N)	6.50 (165)	6.23 (158)	6.62 (168)	2.29 (58)	6.39 (162)	2.72 (69)	4.18 (106)	4.18 (106)	1.26 (32)
	D2	D3	D4	D5	H1	H2	H3	H4	
	1.82 (46)	2.29 (58)	3.15 (80)	0.46 (11.5)	2.13 (54)	7.37 (187)	9.49 (241)	2.76 (70)	

For product numbers, see page 62.

MAGNA3 40-80 F (N)

1 x 115, 230 V, 60 Hz

Proportional pressure

Constant pressure

0-10 volts*

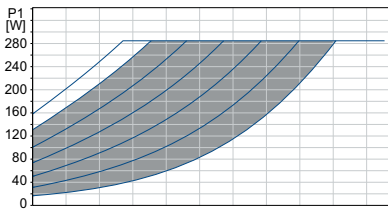
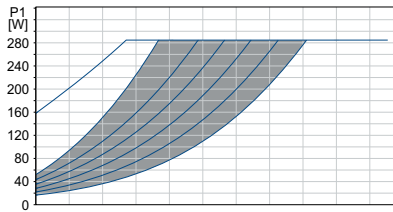
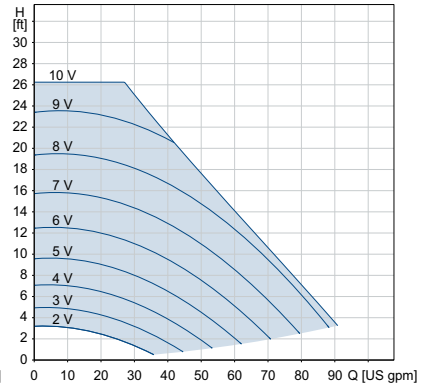
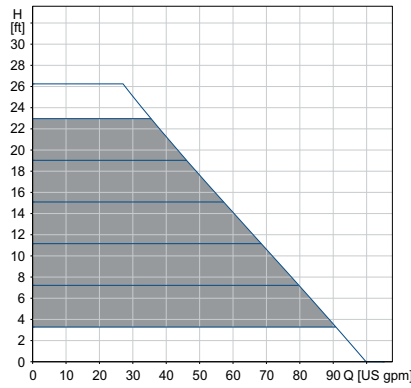
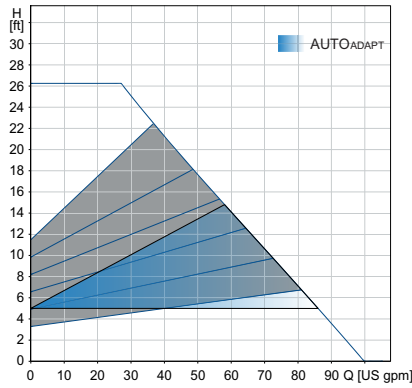

Speed	P1 [W] 115 V	I ₁ [A] 115 V	P1 [W] 230 V	I ₁ [A] 230 V
Min.	16	0.30	16	0.19
Max.	285	2.57	274	1.33

The pump incorporates overload protection.

Net weights [lb (kg)]	Ship. vol. [ft ³ (m ³)]
36.4 (16.5)	1.42 (0.04)

* External setpoint influence shown with a setpoint of H_{max}

- Connections: GF15/26/40/43 flanges. See [Pipe connections](#), page 61.
- System pressure: Max. 175 psi (1.2 MPa) (12 bar).
- Liquid temperature: 14 to 230 °F (-10 to +110 °C) (TF 110).
- Also available with: Stainless-steel pump housing, type N.
- Specific EEI: 0.20 (115 V)
0.19 (230 V)

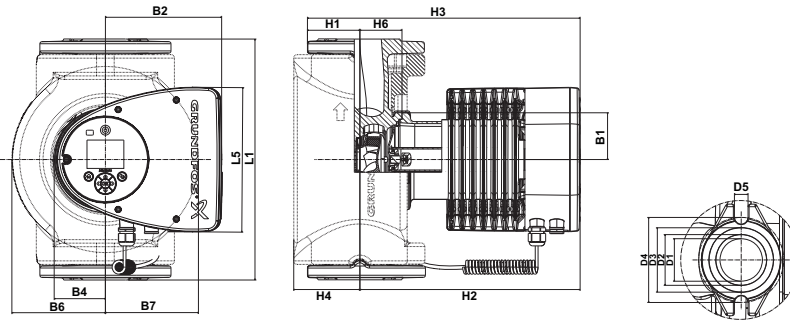

TM05 7651 1413

Pump type	Dimensions [in (mm)]								
	L1	L5	B1	B2	B4	B6	B7	D1	D2
MAGNA3 40-80 F (N)	8.5 (216)	8.03 (204)	3.31 (84)	6.46 (164)	2.87 (73)	4.37 (111)	4.37 (111)	1.57 (40)	1.93 (49)
	D3	D4	D5	H1	H2	H3	H4	H6	
	2.4 (60)	3.15 (80)	0.5 (12.8)	1.46 (37)	11.97 (304)	13.3 (338)	2.76 (70)	1.97 (50)	

For product numbers, see page 62.

MAGNA3 40-120 F (N)

1 x 115, 230 V, 60 Hz

Proportional pressure

Constant pressure

0-10 volts*

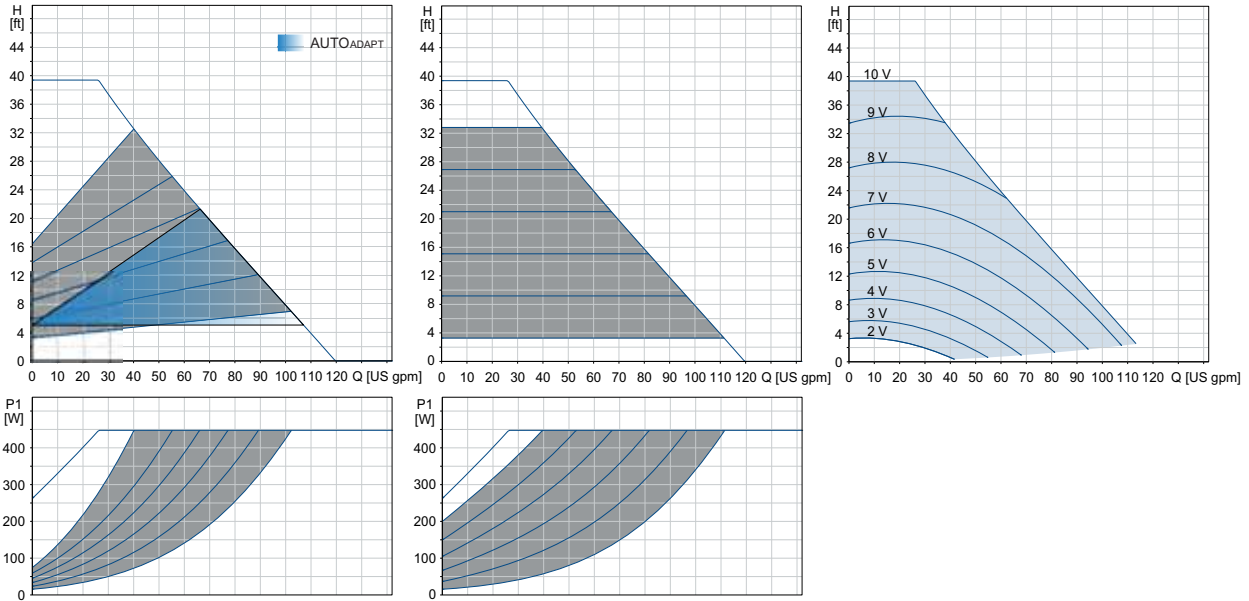

Speed	P1 [W] 115 V	I ₁ [A] 115 V	P1 [W] 230 V	I ₁ [A] 230 V
Min.	16	0.26	16	0.19
Max.	448	3.96	440	2.00

* External setpoint influence shown with a setpoint of H_{max}

The pump incorporates overload protection.

Net weights [lb (kg)]	Ship. vol. [ft ³ (m ³)]
35.8 (16.2)	1.42 (0.04)

Connections:

GF15/26/40/43 flanges.
See [Pipe connections](#), page 61.

System pressure:

Max. 175 psi (1.2 MPa) (12 bar).

Liquid temperature:

14 to 230 °F (-10 to +110 °C) (TF 110).

Also available with:

Stainless-steel pump housing, type N.

Specific EEI:

0.19 (115V)

0.19 (230V)

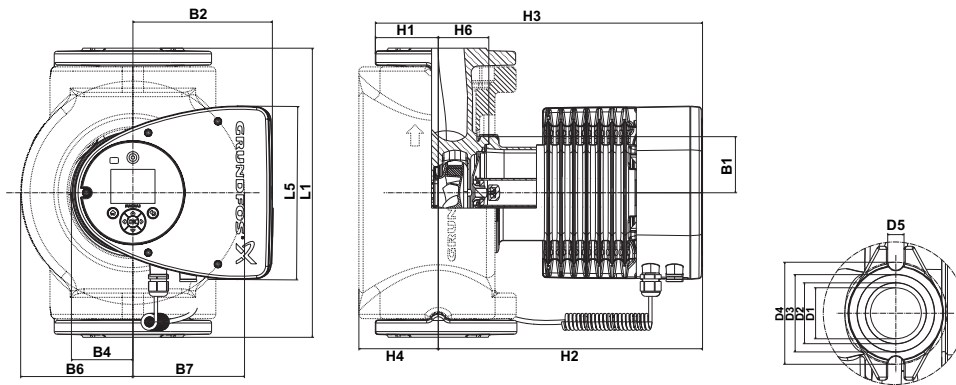

TM05 7651 1413

Pump type	Dimensions [in (mm)]								
	L1	L5	B1	B2	B4	B6	B7	D1	D2
MAGNA3 40-120 F (N)	8.5 (216)	8.03 (204)	3.31 (84)	6.46 (164)	2.87 (73)	4.37 (111)	4.37 (111)	1.57 (40)	1.93 (49)
	D3	D4	D5	H1	H2	H3	H4	H6	
	2.4 (60)	3.15 (80)	0.5 (12.8)	1.46 (37)	11.97 (304)	13.3 (338)	2.76 (70)	1.97 (50)	

For product numbers, see page 62.

MAGNA3 40-180 F (N)

1 x 115, 230 V, 60 Hz

Proportional pressure

Constant pressure

0-10 volts*

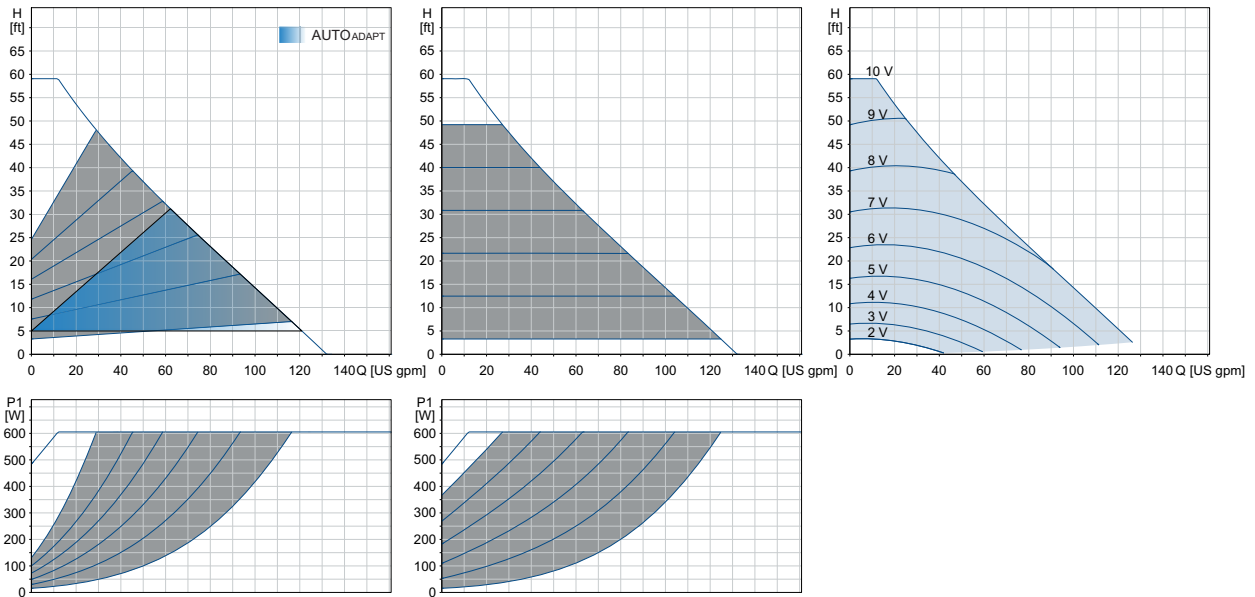

Speed	P1 [W] 115 V	I ₁ [A] 115 V	P1 [W] 230 V	I ₁ [A] 230 V
Min.	16	0.26	16	0.18
Max.	606	5.26	600	2.65

* External setpoint influence shown with a setpoint of H_{max}

The pump incorporates overload protection.

Net weights [lb (kg)]	Ship. vol. [ft ³ (m ³)]
35.8 (16.2)	1.42 (0.04)

Connections: GF15/26/40/43 flanges.
See [Pipe connections](#), page 61.
System pressure: Max. 175 psi (1.2 MPa) (12 bar).
Liquid temperature: 14 to 230 °F (-10 to +110 °C) (TF 110).
Also available with: Stainless-steel pump housing, type N.
Specific EEI: 0.18 (115V)
0.19 (230V)

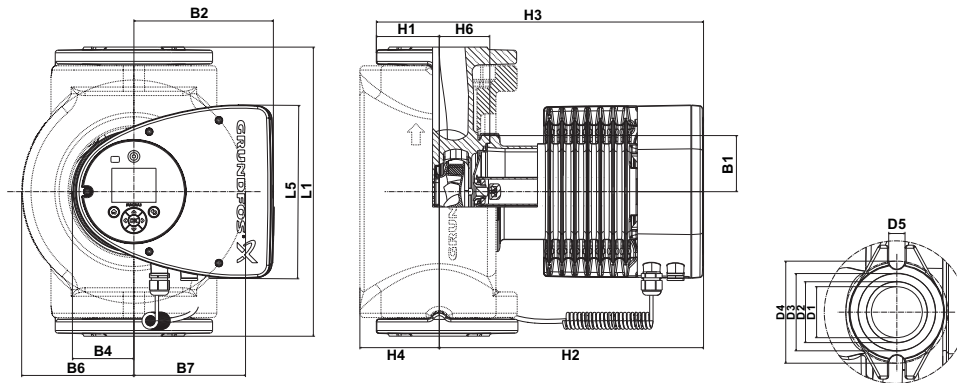

TM05 7651 1413

Pump type	Dimensions [in (mm)]								
	L1	L5	B1	B2	B4	B6	B7	D1	D2
MAGNA3 40-180 F (N)	8.5 (216)	8.03 (204)	3.31 (84)	6.46 (164)	2.87 (73)	4.37 (111)	4.37 (111)	1.57 (40)	1.93 (49)
	D3	D4	D5	H1	H2	H3	H4	H6	
	2.4 (61)	3.15 (80)	0.5 (12.8)	1.46 (37)	11.97 (304)	13.3 (338)	2.76 (70)	1.97 (50)	

For product numbers, see page 62.

MAGNA3 50-80 F (N)

1 x 115, 230 V, 60 Hz

Proportional pressure

Constant pressure

0-10 volts*

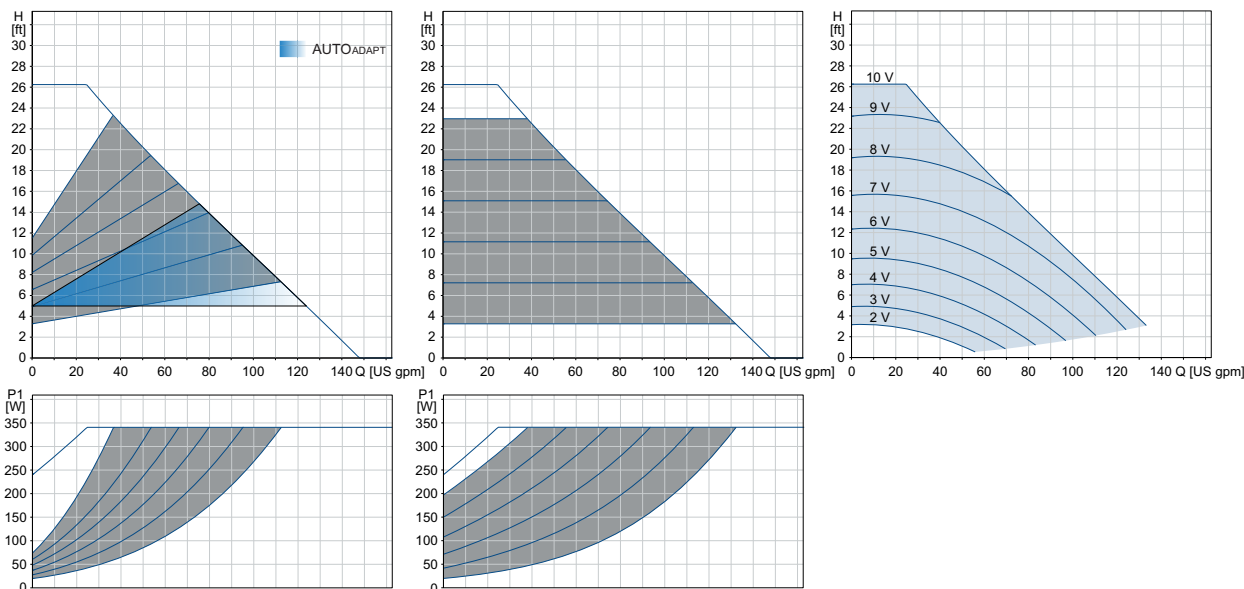

Speed	P1 [W] 115 V	I ₁ [A] 115 V	P1 [W] 230 V	I ₁ [A] 230 V
Min.	18.5	0.31	18.5	0.22
Max.	341	3.09	330	1.58

* External setpoint influence shown with a setpoint of H_{max}

The pump incorporates overload protection.

Net weights [lb (kg)]	Ship. vol. [ft ³ (m ³)]
39.3 (17.8)	1.77 (0.05)

Connections:

GF53 flanges.
See [Pipe connections](#), page 61.

System pressure: Max. 175 psi (1.2 MPa) (12 bar).
Liquid temperature: 14 to 230 °F (-10 to +110 °C) (TF 110).

Also available with: Stainless-steel pump housing, type N.
Specific EEI: 0.19 (115V)
0.18 (230V)

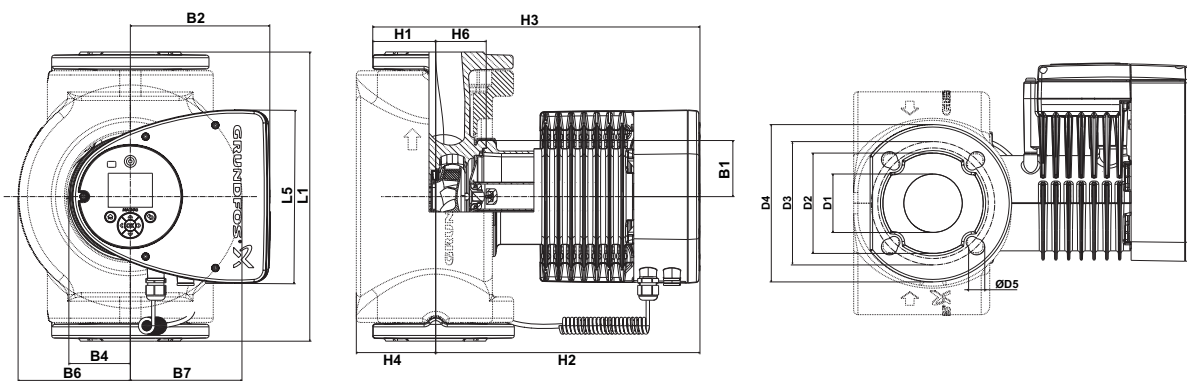

TM05 7652 1413

Pump type	Dimensions [in (mm)]								
	L1	L5	B1	B2	B4	B6	B7	D1	D2
MAGNA3 50-80 F (N)	9.45 (240)	8.03 (204)	3.31 (84)	6.46 (164)	2.87 (73)	5 (127)	5 (127)	1.97 (50)	3.90 (99)
	D3	D4	D5	H1	H2	H3	H4	H6	
	4.33/4.92 (110/125)	6.5 (165)	0.55/0.75 (14/19)	2.8 (71)	12.05 (306)	14.84 (377)	3.82 (97)	2.05 (52)	

For product numbers, see page 62.

MAGNA3 50-150 F (N)

1 x 115, 230 V, 60 Hz

Proportional pressure

Constant pressure

0-10 volts*

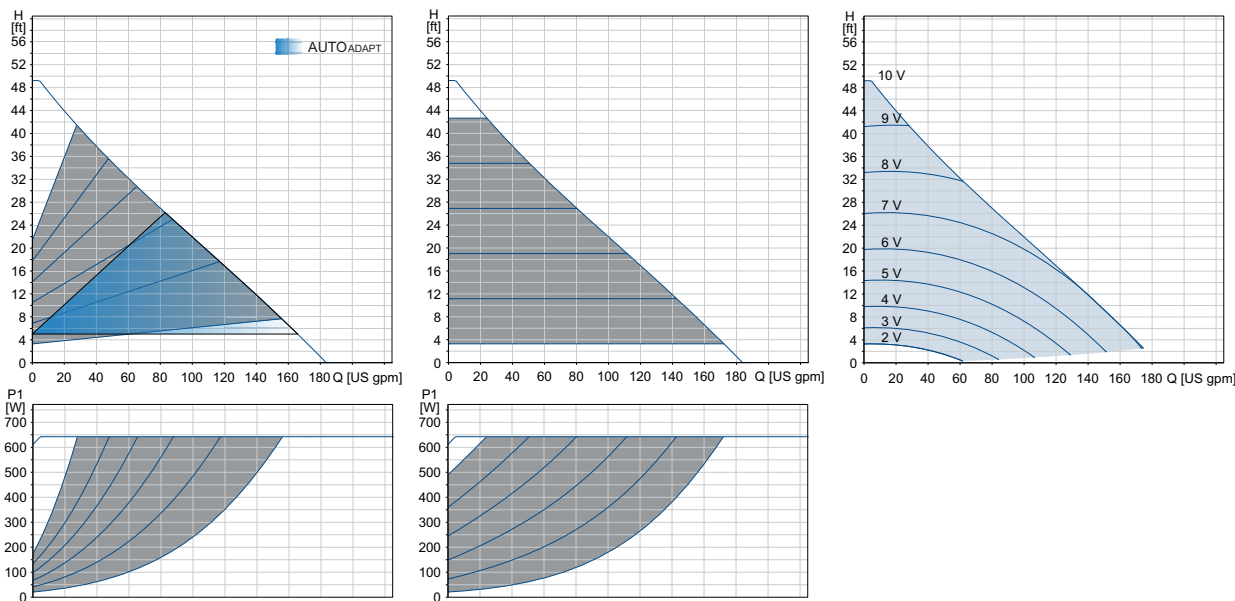

Speed	P1 [W] 115 V	I ₁ [A] 115 V	P1 [W] 230 V	I ₁ [A] 230 V
Min.	18.5	0.31	18.5	0.23
Max.	643	5.69	598	2.87

* External setpoint influence shown with a setpoint of H_{max}

The pump incorporates overload protection.

Net weights [lb (kg)]	Ship. vol. [ft ³ (m ³)]
42.2 (19.1)	1.77 (0.05)

Connections:

GF53 flanges.

See [Pipe connections](#), page 61.

System pressure:

Max. 175 psi (1.2 MPa) (12 bar).

Liquid temperature:

14 to 230 °F (-10 to +110 °C) (TF 110).

Also available with:

Stainless-steel pump housing, type N.

Specific EEI:

0.18 (115V)

0.17(230V)

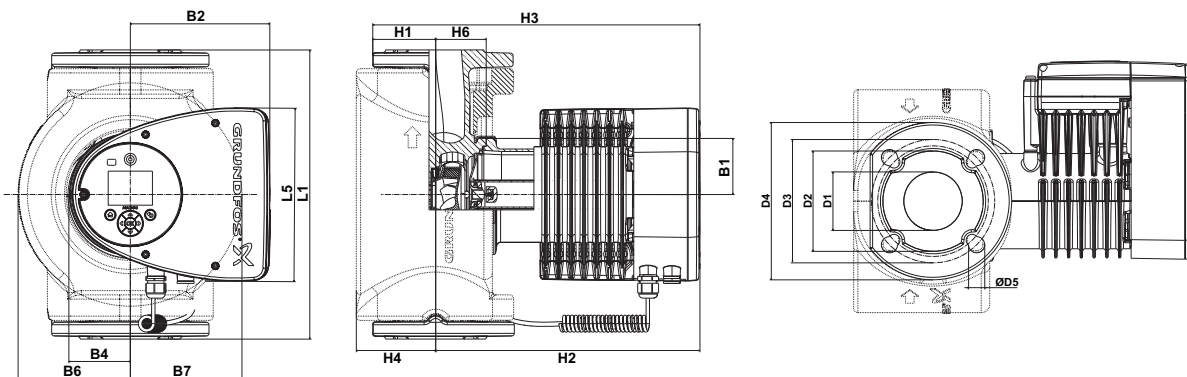

TM05 7652 1413

Pump type	Dimensions [in (mm)]									
	L1	L5	B1	B2	B4	B6	B7	D1	D2	
MAGNA3 50-150 F (N)	11.02 (280)	8.03 (204)	3.31 (84)	6.46 (164)	2.87 (73)	5 (127)	5 (127)	1.97 (50)	3.90 (99)	
	D3	D4	D5	H1	H2	H3	H4	H6		
	4.33/4.92 (110/125)	6.5 (165)	0.55/0.75 (14/19)	2.83 (72)	12.05 (306)	14.9 (378)	3.82 (97)	2.05 (52)		

For product numbers, see page 62.

MAGNA3 65-120 F (N)

1 x 115, 230 V, 60 Hz

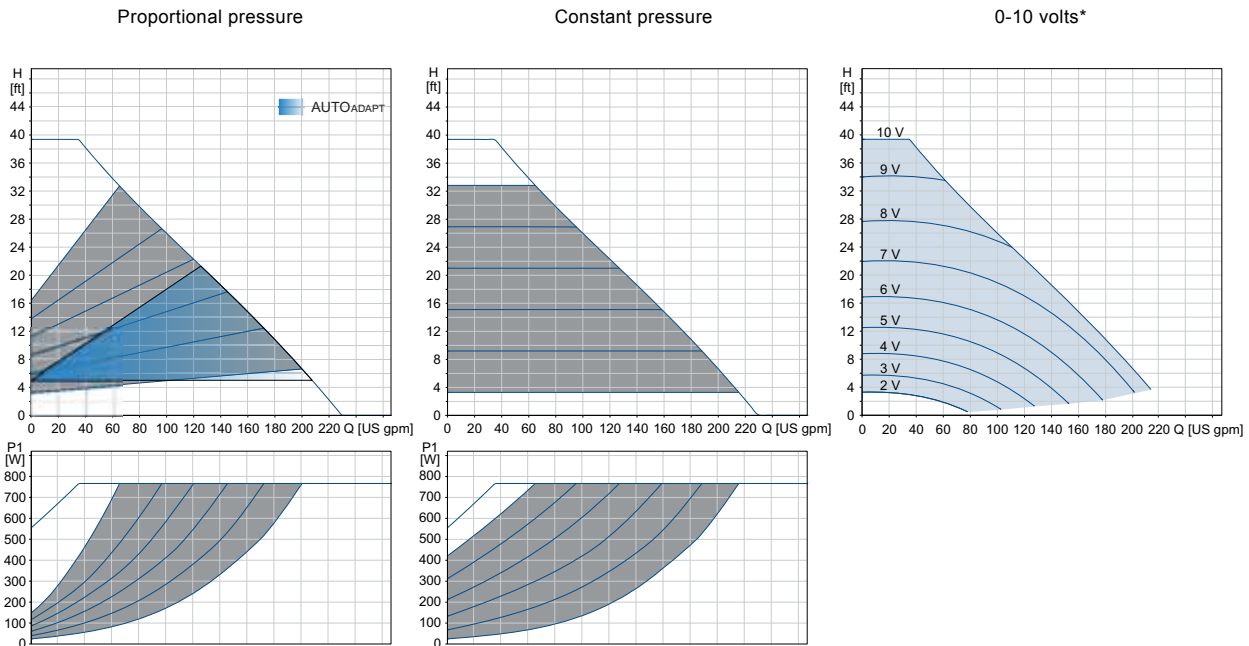

Speed	P1 [W] 115 V	I ₁ [A] 115 V	P1 [W] 230 V	I ₁ [A] 230 V
Min.	20.5	0.36	0.18	20.5
Max.	767	6.75	758	3.32

The pump incorporates overload protection.

Net weights [lb (kg)]	Ship. vol. [ft ³ (m ³)]
47.4 (21.5)	2.12 (0.06)

* External setpoint influence shown with a setpoint of H_{max}

Connections: GF53/65 flanges. See [Pipe connections](#), page 61.
 System pressure: Max. 175 psi (1.2 MPa) (12 bar).
 Liquid temperature: 14 to 230 °F (-10 to +110 °C) (TF 110).
 Also available with: Stainless-steel pump housing, type N.
 Specific EEI: 0.17 (115V) / 0.17 (230V)

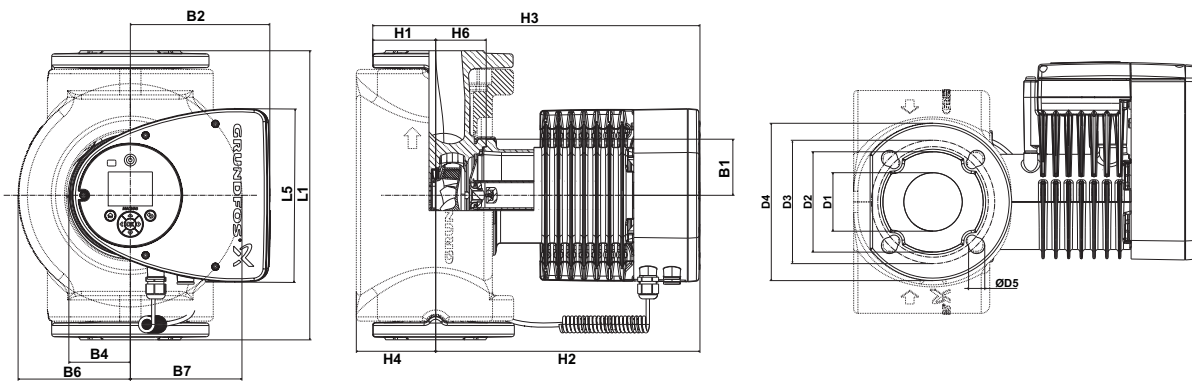

TM05 7652 1413

Pump type	Dimensions [in (mm)]									
	L1	L5	B1	B2	B4	B6	B7	D1	D2	
MAGNA3 65-120 F (N)	13.4 (340)	8.03 (204)	3.31 (84)	6.46 (164)	2.87 (73)	5.24 (133)	5.24 (133)	2.56 (65)	4.65 (118)	
	D3	D4	D5	H1	H2	H3	H4	H6		
	5.0/5.51 (127/140)	7.28 (185)	0.63/0.75 (16/19)	2.91 (74)	12.28 (312)	15.2 (386)	3.7 (94)	2.32 (59)		

For product numbers, see page 62.

MAGNA3 65-150 F (N)

1 x 230 V, 60 Hz

Proportional pressure

Constant pressure

0-10 volts*

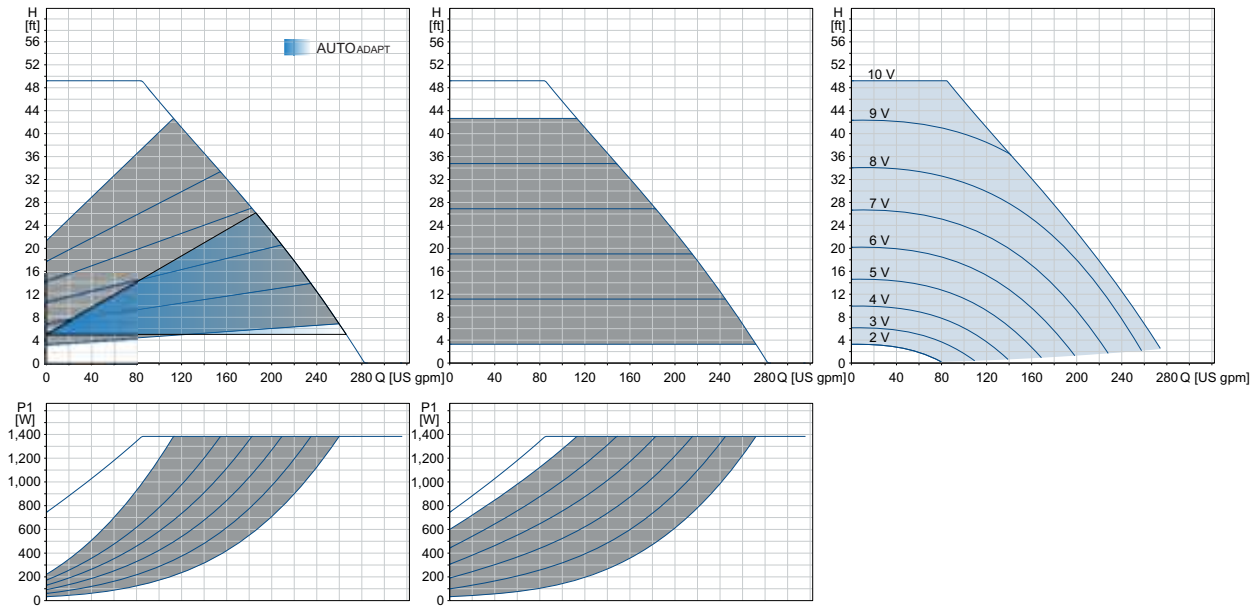

Speed	P1 [W] 230 V	I ₁ [A] 230 V
Min.	31	0.32
Max.	1385	6.10

The pump incorporates overload protection.

Net weights [lb (kg)]	Ship. vol. [ft ³ (m ³)]
66.2 (30.0)	2.12 (0.06)

* External setpoint influence shown with a setpoint of H_{max}

Connections:

GF53/65 flanges.

See [Pipe connections](#), page 61.

System pressure:

Max. 175 psi (1.2 MPa) (12 bar).

Liquid temperature:

14 to 230 °F (-10 to +110 °C) (TF 110).

Also available with:

Stainless-steel pump housing, type N.

Specific EEI:

0.17.

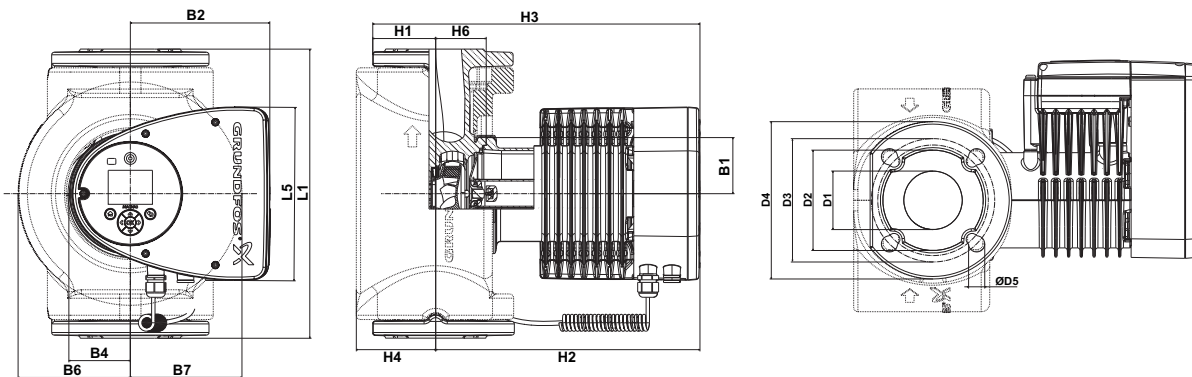

TM05 7652 1413

Pump type	Dimensions [in (mm)]								
	L1	L5	B1	B2	B4	B6	B7	D1	D2
MAGNA3 65-150 F (N)	13.4 (340)	8.03 (204)	3.31 (84)	6.46 (164)	2.87 (73)	5.24 (133)	5.24 (133)	2.56 (65)	4.65 (118)
	D3	D4	D5	H1	H2	H3	H4	H6	
	5.0/5.51 (127/140)	7.28 (185)	0.63/0.75 (16/19)	2.91 (74)	12.28 (312)	15.2 (386)	3.7 (94)	2.32 (59)	

For product numbers, see page 62.

MAGNA3 D 65-150 F

1 x 230 V, 60 Hz

Proportional pressure

Constant pressure

0-10 volt*

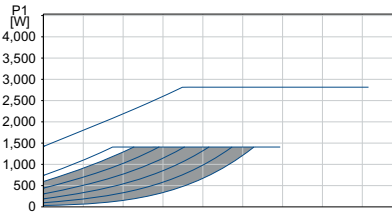
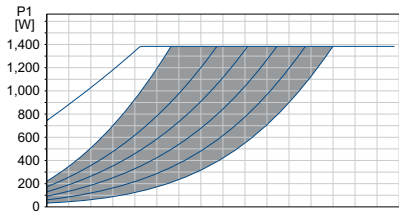
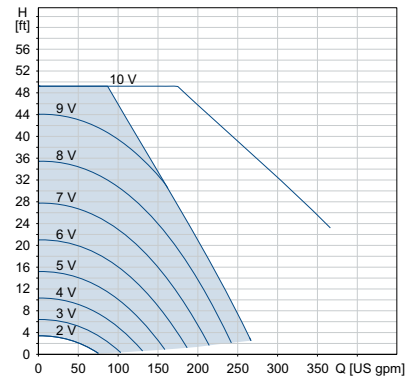
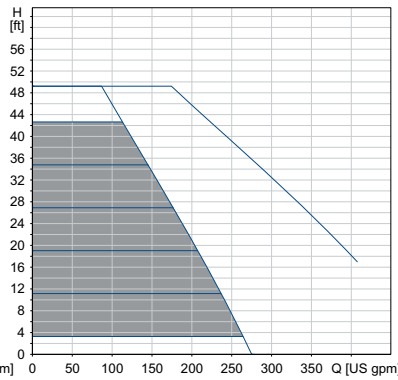
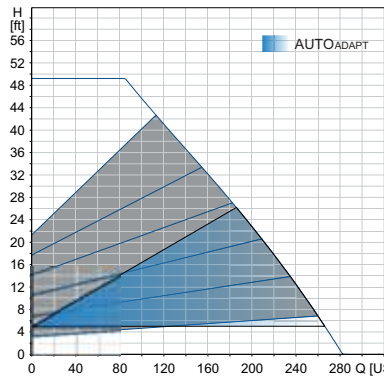

Speed	P1 [W] 230 V	I ₁ [A] 230 V
Min.	29	0.30
Max.	1409	6.18

The pump incorporates overload protection.

Net weights [lb (kg)]	Ship. vol. [ft ³ (m ³)]
101 (45.8)	2.12 (0.06)

* External setpoint influence shown with a setpoint of H_{max}

Connections: GF53/65 flanges.
See [Pipe connections](#), page 61.
System pressure: Max. 175 psi (1.2 MPa) (12 bar).
Liquid temperature: 14 to 230 °F (-10 to +110 °C) (TF 110).
Specific EEI: 0.17.

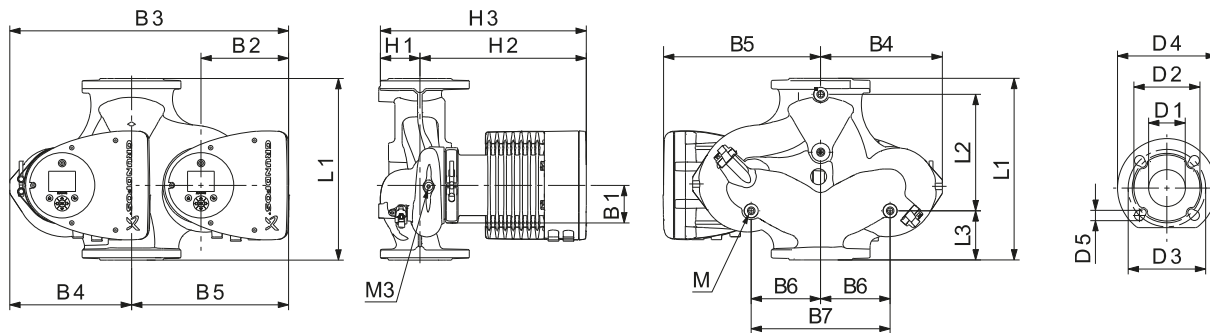

TM05 2205 2214

Pump type	Dimensions [in (mm)]								
	L1	L2	L3	L4	L5	B1	B3	B4	B5
MAGNA3 D 65-150 F	13.4 (340)	8.58 (218)	3.62 (92)	3.62 (92)	8.03 (204)	3.31 (84)	20.55 (522)	8.98 (228)	11.57 (294)
	D1	D2	D3	D4	D5	D5 (2)	M	M1	H1
	2.56 (65)	4.69 (119)	5.12/5.71 (130/145)	7.28 (185)	0.55 (14)	0.75 (19)	M12	Rp 1/4	3.03 (77)

For product numbers, see page 62.

MAGNA3 80-100 F (N)

1 x 230 V, 60 Hz

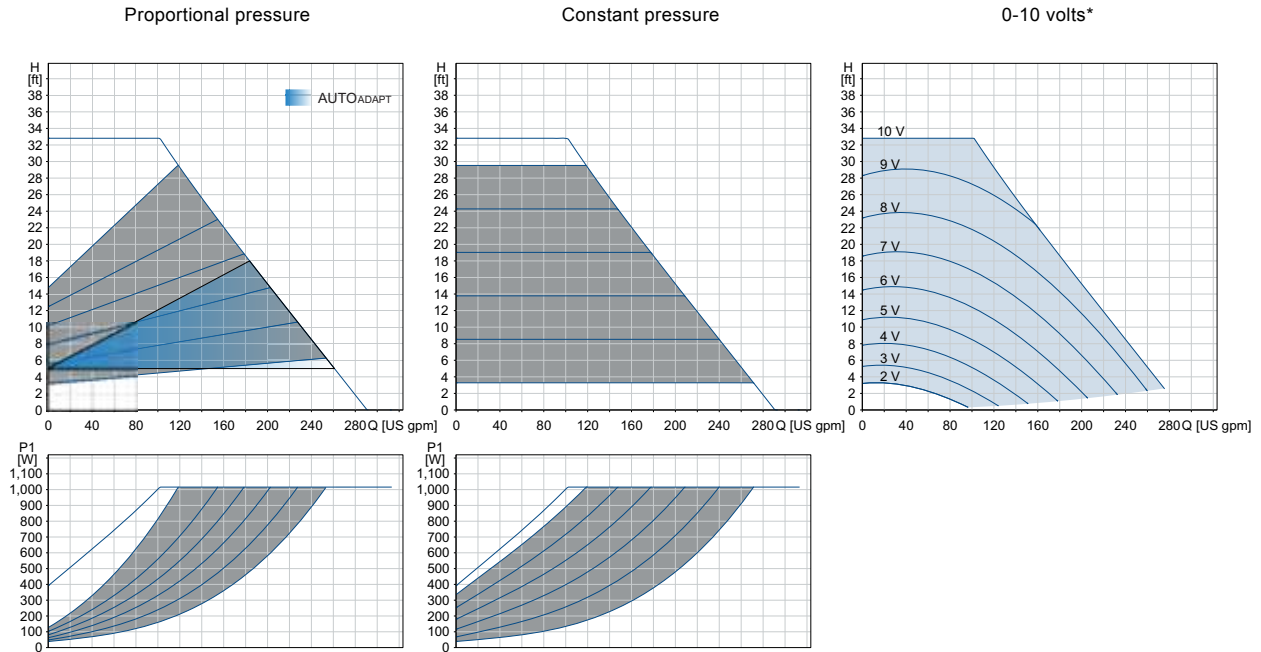

Speed	P1 [W] 230 V	I _l [A] 230 V
Min.	31	0.32
Max.	1017	4.51

The pump incorporates overload protection.

Net weights [lb (kg)]	Ship. vol. [ft ³ (m ³)]
66.2 (30.0)	2.47 (0.07)

* External setpoint influence shown with a setpoint of H_{max}

Connections:

GF80 flanges.
See [Pipe connections](#), page 61.

System pressure:
Liquid temperature:
Specific EEI:

Max. 175 psi (1.2 MPa) (12 bar).
14 to 230 °F (-10 to +110 °C) (TF 110).
0.17.

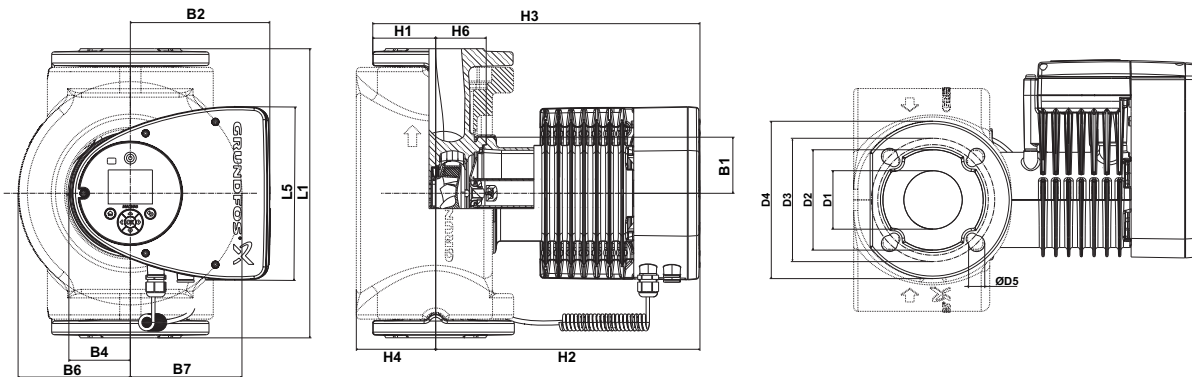

TM05 7652 1413

Pump type	Dimensions [in (mm)]									
	L1	L5	B1	B2	B4	B6	B7	D1	D2	
MAGNA3 80-100 F (N)	14.17 (360)	8.03 (204)	3.31 (84)	6.46 (164)	2.87 (73)	6.42 (163)	6.42 (163)	3.15 (80)	5.2 (132)	
	D3	D4	D5	H1	H2	H3	H4	H6		
	5.91 (150)	7.87 (200)	0.75 (19)	3.7 (94)	12.52 (318)	16.22 (412)	4.53 (115)	2.6 (66)		

For product numbers, see page 62.

MAGNA3 D 80-100 F

1 x 230 V, 60 Hz

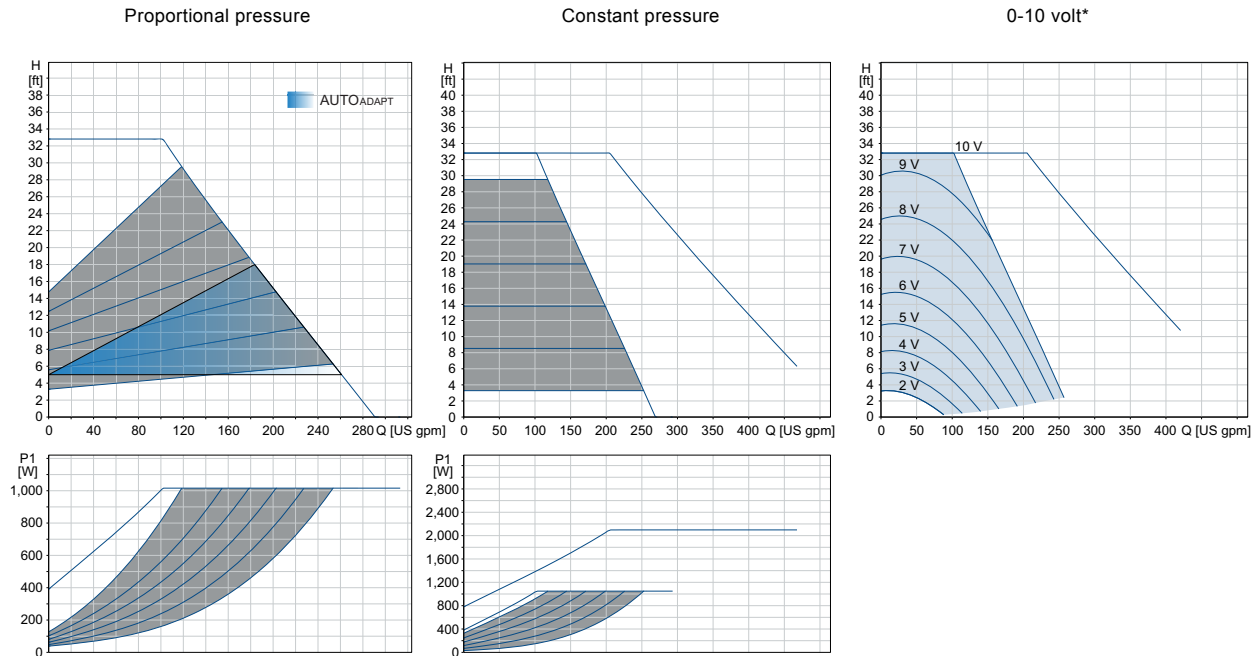

Speed	P1 [W] 230 V	I ₁ [A] 230 V
Min.	32	0.32
Max.	1050	4.71

The pump incorporates overload protection.

Net weights [lb (kg)]	Ship. vol. [ft ³ (m ³)]
116.9 (53.0)	7.5 (0.208)

* External setpoint influence shown with a setpoint of H_{max}

Connections: GF80 flanges. See [Pipe connections](#), page 61.
 System pressure: Max. 175 psi (1.2 MPa) (12 bar).
 Liquid temperature: 14 to 230 °F (-10 to +110 °C) (TF 110).
 Specific EEI: 0.17.

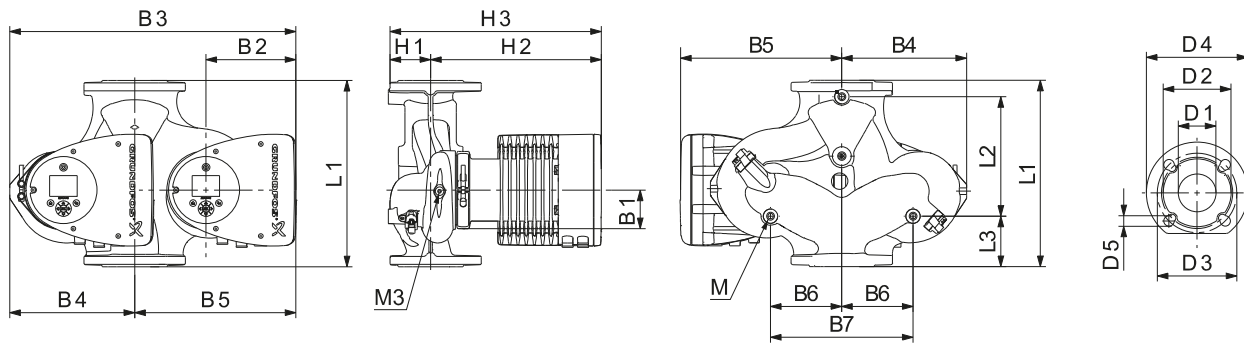

TM05 2205 2214

Pump type	Dimensions [in (mm)]								
	L1	L2	L3	L4	L5	B1	B3	B4	B5
MAGNA3 D 80-100 F	14.17 (360)	8.58 (218)	4.02 (102)	4.02 (102)	8.03 (204)	3.31 (84)	21.18 (538)	9.61 (244)	11.57 (294)
	D1	D2	D3	D3 (2)	D4	D5	M	M1	H1
	3.15 (80)	5.04 (128)	5.91 (150)	6.30 (160)	7.87 (200)	0.75 (19)	M12	Rp 1/4	3.82 (97)

For product numbers, see page 62.

MAGNA3 100-120 F (N)

1 x 230 V, 60 Hz

Proportional pressure

Constant pressure

0-10 volts*

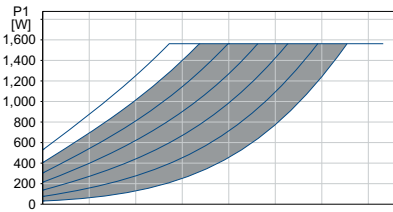
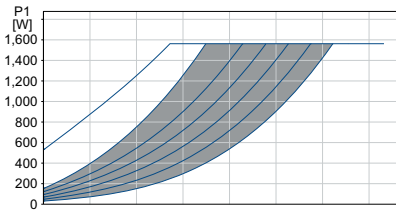
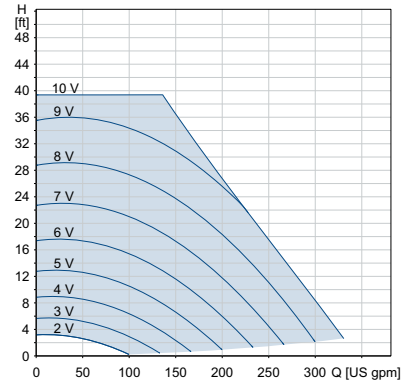
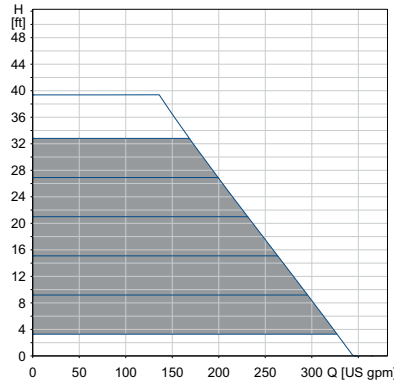
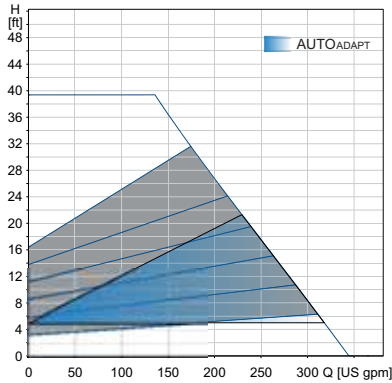

Speed	P1 [W] 230 V	I ₁ [A] 230 V
Min.	31	0.32
Max.	1564	6.78

* External setpoint influence shown with a setpoint of H_{max}

The pump incorporates overload protection.

Net weights [lb (kg)]	Ship. vol. [ft ³ (m ³)]
76.8 (34.8)	3.53 (0.1)

Connections:

GF100 flanges.

See *Pipe connections*, page 61.

System pressure:

Max. 175 psi (1.2 MPa) (12 bar).

Liquid temperature:

14 to 230 °F (-10 to +110 °C) (TF 110).

Specific EEI:

0.17.

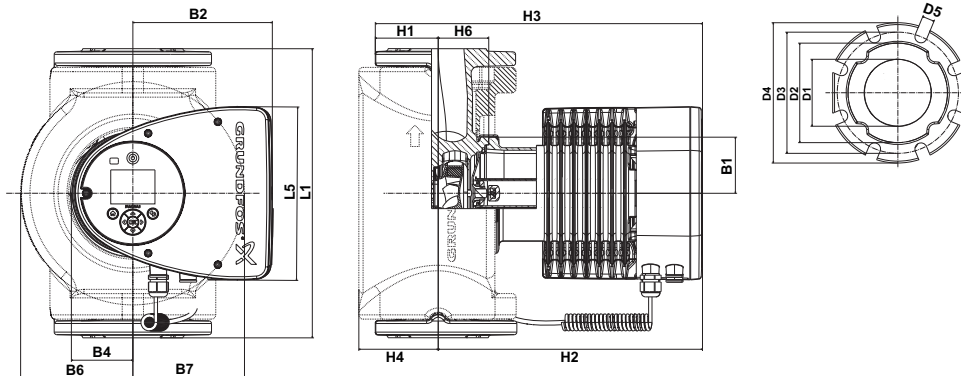

TM05 7650 1413

Pump type	Dimensions [in (mm)]									
	L1	L5	B1	B2	B4	B6	B7	D1	D2	
MAGNA3 100-120 F (N)	17.72 (450)	8.03 (204)	3.31 (84)	6.46 (164)	2.87 (73)	7.01 (178)	7.01 (178)	3.94 (100)	6.14 (156)	
	D3	D4	D5	H1	H2	H3	H4	H6		
	7.52 (191)	8.66 (220)	0.75 (19)	4.02 (102)	12.99 (330)	17.01 (432)	4.72 (120)	3.11 (79)		

For product numbers, see page 62.

MAGNA3 D 100-120 F

1 x 230 V, 60 Hz

Proportional pressure

Constant pressure

0-10 volts*

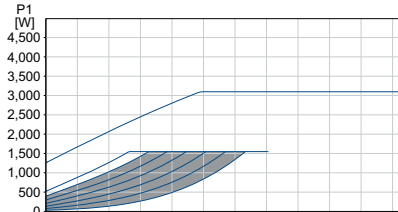
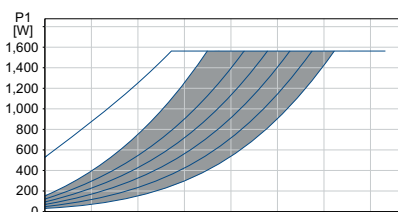
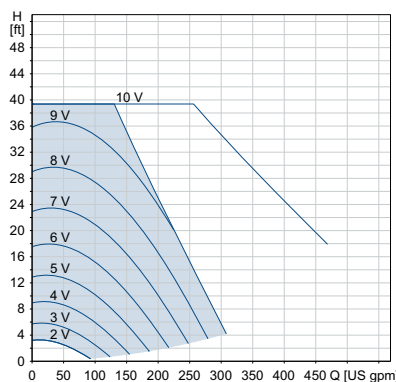
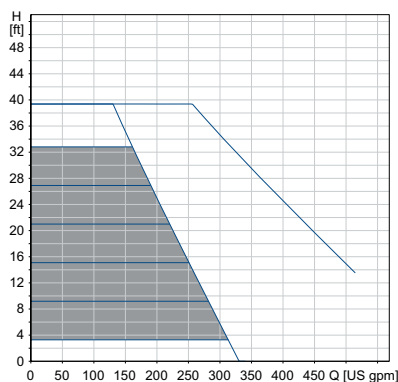
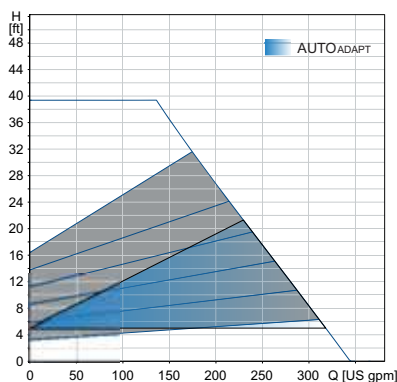

Speed	P1 [W] 230 V	I ₁ [A] 230 V
Min.	35	0.35
Max.	1550	6.78

* External setpoint influence shown with a setpoint of H_{max}

The pump incorporates overload protection.

Net weights [lb (kg)]	Ship. vol. [ft ³ (m ³)]
138.3 (62.7)	7.4 (0.208)

Connections: GF100 flanges.
See [Pipe connections](#), page 61.
System pressure: Max. 175 psi (1.2 MPa) (12 bar).
Liquid temperature: -14 to 230 °F (10 to +110 °C) (TF 110).
Specific EEI: 0.17.

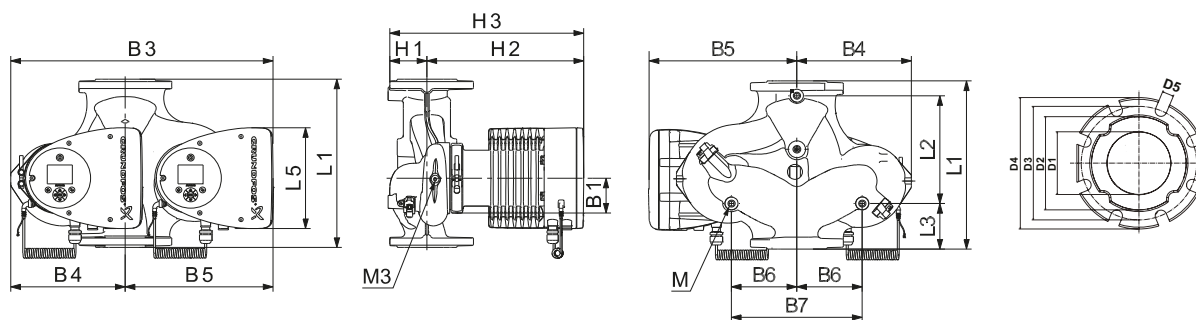

TM05 7701 1214

Pump type	Dimensions [in (mm)]								
	L1	L2	L3	L4	L5	B1	B3	B4	B5
MAGNA3 D 100-120 F	17.72 (450)	9.57 (243)	5.79 (147)	5.79 (147)	8.03 (204)	3.31 (84)	21.69 (551)	9.92 (252)	11.77 (299)
	D1	D2	D3	D4	D5	M	M1	H1	H2
	3.94 (100)	6.3 (160)	6.69 (170)	8.66 (220)	0.75 (19)	M12	Rp 1/4	4.06 (103)	12.99 (330)

For product numbers, see page 62.

10. Accessories

Insulating kits for air-conditioning and cooling systems

Single-head MAGNA3 pumps for air-conditioning and cooling systems can be fitted with insulating shells. A kit consists of two shells made of polyurethane (PUR) and metal clamps to ensure tight assembly.



TM05 2874 0412

Fig. 59 Fitting the insulating shells to a MAGNA3 pump

Note: The dimensions of the insulating shells for air-conditioning and cooling systems differ from those of the insulating shells for heating systems. You can use the insulating shells for both stainless-steel and cast-iron pumps.

The following insulating shells for air conditioning and cooling systems are available:

Pump type	Product number
MAGNA3 50-80 F (N)	98063289
MAGNA3 50-150 F (N)	98145676
MAGNA3 65-120 F (N)	96913593
MAGNA3 80-100 F	98134265

Note: Insulating shells for single-head pumps for heating systems are supplied with the pump. You can order the insulating shells as service kits in Grundfos Product Center.

Specifications:

- Specific volume resistance greater than or equal to $10^{15} \Omega\text{cm}$, DIN 60093
- thermal conductivity at 10 °C 0.036 W/mK and at 40 °C 0.039 W/mK, DIN 52612
- density $33 \pm 5 \text{ kg/m}^3$, ISO 845
- working temperature range -40/+90 °C, ISO 2796.

CIM modules

A CIM module is an add-on Communication Interface Module. The CIM module enables data transmission between the pump and an external system, for example a BMS or SCADA system.

The CIM module communicates via fieldbus protocols. The following CIM modules are available:

Module	Fieldbus protocol	Product number
CIM 050	GENIbus	96824631
CIM 100	LonWorks	96824797
CIM 200	Modbus RTU	96824796
CIM 300	BACnet MS/TP	96893770
CIM 500	Ethernet	98301408

For further information about data communication via CIM modules, see the CIM documentation available in Grundfos Product Center.

Location of CIM module

The CIM module is fitted behind the front cover. See fig. 60.

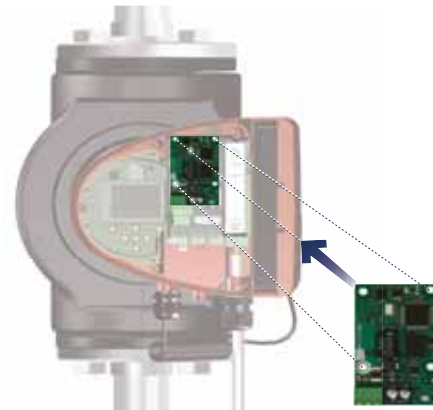

TM05 2914 1112

Fig. 60 Location of CIM module

For installation instructions, please go to:



net.grundfos.com/qr/i/99332342

Reuse of CIM modules

You can reuse a CIM module in a CIU unit used together with Grundfos MAGNA in MAGNA3. You must re-configure the CIM module before you use it in a MAGNA3 pump. Contact your local Grundfos company.

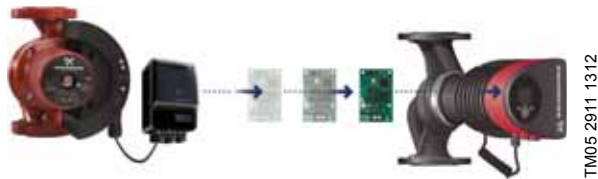

Fig. 61 Reusing CIM modules

Grundfos GO

Grundfos GO is used for infrared or radio communication with the pumps. Various Grundfos GO variants are available. The variants are described in the following.

MI 204

MI 204 is an add-on module with built-in infrared and radio communication. You can use MI 204 in conjunction with an Apple iPhone or iPod with Lightning connector, e.g. a fifth generation iPhone or iPod.

MI 204 is also available together with an Apple iPod touch and a cover.



Fig. 62 MI 204

Supplied with the product:

- Grundfos MI 204
- sleeve
- quick guide
- charger cable.

MI 301

MI 301 is a module with built-in infrared and radio communication. Use MI 301 in conjunction with an Android or iOS-based smart device with a Bluetooth connection. MI 301 has a rechargeable Li-ion battery and must be charged separately.



Fig. 63 MI 301

Supplied with the product:

- Grundfos MI 301
- battery charger
- quick guide.

Product numbers

Grundfos GO variant	Product number
Grundfos MI 204	98424092
Grundfos MI 204 including iPod touch	98612711
Grundfos MI 301	98046408

External Grundfos sensors

Combined relative-pressure and temperature transmitter

Sensor	Type	Supplier	Measuring range [psi (bar)]	Measuring range [°F (°C)]	Transmitter output [VDC]	Power supply [VDC]	Process connection	Product number
Combined pressure and temperature sensor	RPI T2	Grundfos	0-232 (0-16)	14 to 248 (-10 to +120)	0-10	16.6-30	G 1/2	98355521

Note: MAGNA3 has only one analog input.

Pressure sensor

Sensor	Type	Measuring range [psi]	Measuring range [bar]	Transmitter output [mA]	Power supply [VDC]	Process connection	Product number
Pressure transmitter	RPI	0-9	(0 - 0.6)	4 to 20	12 to 30	G 1/2	97748907
		0-15	(0 - 1.0)				97748908
		0-25	(0 - 1.6)				97748909
		0-35	(0 - 2.5)				97748910

10.1 Adapters

Adapter

Adapter for 1/4" NPT	98344015
----------------------	----------

DPI V.2 transmitter

Combined differential-pressure and temperature transmitter

Scope of delivery:

- DPI V.2 transmitter
- open 6.5 ft (2 m) cable with M12 connection in one end
- capillary tube with fitting
- quick guide.



TM04 7866 2510

Fig. 64 DPI V.2 transmitter

Sensor	Measuring range [psi (bar)]	Measuring range [°F (°C)]	Transmitter output	Power supply [VDC]	Temperature measurement	O-ring EPDM*	Process connection	Product number
Grundfos DPI	0 - 8.7 (0 - 0.6)	32-212 (0-100)	4-20 mA	12.5 - 30	•	•	G 1/2	97747194
			0-10 VDC	16.5 - 30				97747202
Grundfos DPI	0 - 14.5 (0 - 1.0)	32-212 (0-100)	4-20 mA	12.5 - 30	•	•	G 1/2	97747195
			0-10 VDC	16.5 - 30				97747203
Grundfos DPI	0 - 23.2 (0 - 1.6)	32-212 (0-100)	4-20 mA	12.5 - 30	•	•	G 1/2	97747196
			0-10 VDC	16.5 - 30				97747204
Grundfos DPI	0 - 36.26 (0 - 2.5)	32-212 (0-100)	4-20 mA	12.5 - 30	•	•	G 1/2	97747197
			0-10 VDC	16.5 - 30				97747205

* **Note:**

EPDM: approved for potable water.

FKM: for use in oily media.

Cable for sensors

Description	Length [ft (m)]	Product number
Screened cable	6.5 (2.0)	98374260
Screened cable	16.4 (5.0)	98374271

Blanking flange

A blanking flange is used to blank off the opening when one of the pump heads of a twin-head pump is removed for service to enable uninterrupted operation of the other pump.

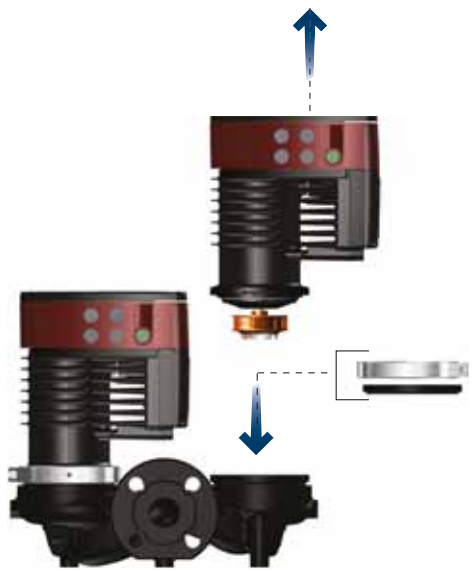

TM06 8518 0817

Fig. 65 Position of a blanking flange

Pump type	Product number
MAGNA3 D 65-150 F	98159372
MAGNA3 D 80-100 F	
MAGNA3 D 100-120 F	

Pipe connections

Material	Flange	Description	Part number
		3/4" NPT flange fitting set	519601
		1" NPT flange fitting set	519602
	GF 15/26 flange	1-1/4" NPT flange fitting set	519603
		1-1/2" NPT flange fitting set	519604
	GF 40/43 flange	1-1/2" NPT flange fitting set	539605
Cast iron	GF 50 flange	2" NPT flange fitting set	96409354
		2" NPT flange fitting set	91584910
	GF 53 flange	2-1/2" NPT flange fitting set	91584911
		3" NPT flange fitting set	91584912
	GF 65 flange	2-1/2" NPT flange fitting set	559601
	GF 80 flange	3" NPT flange fitting set	569601
	GF 100 flange	4" NPT flange fitting set	579801
	Stainless steel	GF 65 flange	Stainless steel, 2-1/2" NPT flange fitting set
Replacement flange gaskets			
	GF 15/40	2-bolt, single o-ring for 1-1/2" flange	98476425

11. Product numbers

Single-head pumps

Single-head pump type	Port-to-port length [in. (mm)]	Flange connection	Cast iron		Stainless steel (N)		Page
			115 V	208-230 V	115 V	208-230 V	
MAGNA3 32-60 F (N)	6 - 1/2 (165)	PN 12	98126820		98126822		43
MAGNA3 32-100 F (NA)	6 - 1/2 (165)	PN 12	98126824		98126826		44
MAGNA3 40-80 F (N)	8 - 9/16 (216)	PN 12	98126800	98126828	98126802	98126830	45
MAGNA3 40-120 F (N)	8 - 9/16 (216)	PN 12	98126804	98126832	98126806	98126834	46
MAGNA3 40-180 F (N)	8 - 9/16 (216)	PN 12	98126808	98126836	98126810	98126838	47
MAGNA3 50-80 F (N)	9 - 1/2 (240)	PN 12	98126812	98126840	98126814	98126842	48
MAGNA3 50-150 F (N)	11 - 1/16 (280)	PN 12	98126816	98126844	98126818	98126846	49
MAGNA3 65-120 F (N)	13 - 7/16 (340)	PN 12	98124696	98126848	98124702	98126850	50
MAGNA3 65-150 F (N)	13 - 7/16 (340)	PN 12	-	98126852	-	98126854	51
MAGNA3 80-100 F (N)	14 - 3/16 (360)	PN 12	-	98126856	-	98126858	53
MAGNA3 100-120 F (N)	17 - 3/4 (450)	PN 12	-	98126860	-	98126862	55

Twin-head pumps

Twin-head pump type	Port-to-port length [in. (mm)]	Flange connection	Cast iron		Stainless steel (N)		Page
			115 V	208-230 V	115 V	208-230 V	
MAGNA3 D 65-150 F	13 - 7/16 (340)	PN 12	-	98126863	-	-	52
MAGNA3 D 80-100 F	14 - 3/16 (360)	PN 12	-	98126864	-	-	54
MAGNA3 D 100-120 F	17 - 3/4 (450)	PN 12	-	98126865	-	-	56

Note: Click on the product number and go directly to the performance curve in Grundfos Product Center.

12. Grundfos Product Center

Online search and sizing tool to help you make the right choice.

<http://product-selection.grundfos.com>

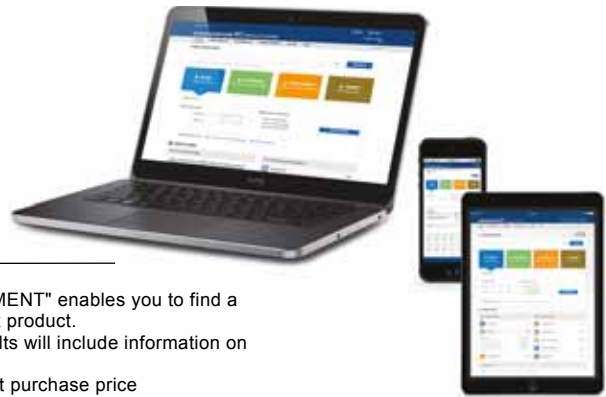

"SIZING" enables you to size a pump based on entered data and selection choices.

"REPLACEMENT" enables you to find a replacement product. Search results will include information on

- the lowest purchase price
- the lowest energy consumption
- the lowest total life cycle cost.

"CATALOG" gives you access to the Grundfos product catalog.

"LIQUIDS" enables you to find pumps designed for aggressive, flammable or other special liquids.

All the information you need in one place

Performance curves, technical specifications, pictures, dimensional drawings, motor curves, wiring diagrams, spare parts, service kits, 3D drawings, documents, system parts. The Product Center displays any recent and saved items - including complete projects - right on the main page.

Downloads

On the product pages, you can download installation and operating instructions, data booklets, service instructions, etc. in PDF format.

99332363 0718

ECM: 1240096

Grundfos Kansas City

17100 West 118th Terrace
Olathe, Kansas 66061
Phone: 913-227-3400
Fax: 913-227-3500
www.grundfos.us

Grundfos Canada

2941 Brighton Road
Oakville, Ontario L6H 6C9 Canada
Phone: +1-905-829-9533
Fax: +1-905-829-9512
www.grundfos.ca

Grundfos México

Boulevard TLC No. 15
Parque Industrial Stiva Aeropuerto
C.P. 66600 Apodaca, N.L. Mexico
Phone: 011-52-81-8144 4000
Fax: 011-52-81-8144 4010
www.grundfos.mx