



- 1. Product data . . . . . 3**
  - Product introduction . . . . . 3
  - Applications . . . . . 5
  - Features . . . . . 6
  - Pumped liquids . . . . . 7
  
- 2. Performance range . . . . . 8**
  - ALPHA2 15-55 performance range and operating mode selection . . . . . 8
  - ALPHA1 15-55 performance range and operating mode selection . . . . . 9
  - ALPHA2 26-99 performance range . . . . . 10
  - ALPHA1 26-99 performance range . . . . . 11
  - ALPHA 15-55 HWR-D performance range . . . . . 12
  
- 3. Product range . . . . . 13**
  - Product range . . . . . 13
  - Competitor cross reference . . . . . 14
  
- 4. Identification . . . . . 15**
  - Nameplates . . . . . 15
  - Type keys . . . . . 16
  
- 5. Operation . . . . . 17**
  - Operating conditions . . . . . 17
  - Control modes . . . . . 20
  
- 6. Technical data . . . . . 25**
  - Technical data, ALPHA2 15-55 . . . . . 25
  - Technical data, ALPHA1 15-55 . . . . . 26
  - Technical data, ALPHA 26-99 models . . . . . 27
  - Technical data, ALPHA 15-55 HWR-D . . . . . 28
  - Materials . . . . . 29
  - Approvals . . . . . 30
  
- 7. Dimensions and weights . . . . . 32**
  - ALPHA2 15-55 . . . . . 32
  - ALPHA1 15-55 . . . . . 33
  - ALPHA2 26-99 . . . . . 34
  - ALPHA 15-55 HWR-D . . . . . 35
  
- 8. Accessories . . . . . 36**
  - Accessories for ALPHA . . . . . 36

# 1. Product data

## Product introduction

Grundfos ALPHA circulators are medium-sized, speed-controlled, high-efficiency pumps fitted with an electronically commutated motor with permanent-magnet rotor and variable frequency drive. Grundfos ALPHA circulators are designed for domestic building applications such as:

- circulating liquids in heating systems
- hot water recirculation
- air conditioning and cooling systems.

The canned-rotor type pump and motor form an integral unit without a shaft seal with two gaskets for sealing and four screws for fastening the stator housing to the pump housing. The bearings are lubricated by the pumped liquid.



TM074556

**Fig. ALPHA2 15-55**

### ALPHA2 15-55

ALPHA2 15-55 features:

- Three constant pressure modes
- Three constant curve modes
- *AUTOAdapt*

The *AUTOAdapt* function continuously adjusts the pump performance to the actual heat demand, i.e. the size of the system and the changing heat demand during the year. The function will find the setting that provides optimal comfort with minimal energy consumption. It contributes to fast, safe and easy commissioning.

Other features:

- A user-friendly front-mounted user interface.
- Easy installation and start-up. With the *AUTOAdapt* feature (factory setting), the pump does not need any adjustments to the settings in most cases.
- High degree of comfort.
- Minimum noise from valves, etc.
- Low energy consumption compared to conventional circulator pumps.



TM074558

**Fig. ALPHA1 15-55**

### ALPHA1 15-55

ALPHA1 15-55 features:

- Three constant pressure control modes.
- An energy-efficient replacement for older circulator pumps.
- User-friendly front-mounted user interface.
- Easy installation and start-up.
- High degree of comfort.
- Minimum noise from valves, etc.
- Low energy consumption compared to conventional circulator pumps.



TM074557

**Fig. ALPHA2 26-99**

### ALPHA2 26-99

ALPHA2 26-99 features eight different control modes including constant pressure *AUTOAdapt* and proportional pressure *AUTOAdapt*.

The *AUTOAdapt* function continuously adjusts the pump performance to the actual heat demand, i.e. the size of the system and the changing heat demand during the year. The function will find the setting that provides optimal comfort with minimal energy consumption. It contributes to fast, safe and easy commissioning.

A magnetite-resistant design, robust ceramic shaft, and stainless-steel bearing plate ensure that the ALPHA2 26-99 reliably delivers the optimal system performance throughout the years at the lowest possible energy consumption.

**ALPHA1 26-99**

ALPHA1 26-99 circulator pumps are remote-controlled via a low-voltage 0-10 VDC signal by a system controller integrated into a boiler or a building management system. The pump requires a 0-10 V signal on the signal port to control the speed of the pump. The pump will run at its minimum speed if no signal is present or the signal fails.

A magnetite-resistant design, robust ceramic shaft, and stainless-steel bearing plate ensure that the ALPHA1 26-99 reliably delivers the optimal system performance at the lowest possible energy consumption throughout the years.



TM074717

**Fig.** ALPHA 15-55 HWR-D

**ALPHA 15-55 HWR-D**

The ALPHA HWR-D system is an on-command hot water recirculation system for use in domestic hot water applications. The system includes two temperature sensors and a push-button.

A repeater that can extend the range of wireless control for the push-button is also available as an accessory.

To prevent continuous operation, the pump stops recirculating water when:

- a) the media temperature measured at the temperature sensor has increased by 10 °F (5.5 °C) or is higher than 102 °F (38.9 °C).
- b) the pump has been operating continuously for more than 5 minutes, or for a total of 15 minutes during the last hour.

If the system is operated without the temperature sensor, the pump will stop according to b).

## Applications

### **ALPHA2 15-55 and ALPHA1 15-55 applications**

The ALPHA2 15-55 and ALPHA1 15-55 circulators are designed for the circulation of water in heating systems, domestic hot water systems as well as air-conditioning and cold water systems. Cold water systems are defined as systems where the ambient temperature is higher than the temperature of the pumped liquid.

ALPHA2 15-55 and ALPHA1 15-55 circulators are the best choice for the following systems:

- One pipe systems.
- Two pipe systems.
- Underfloor heating.
- Domestic hot water recirculation.
- Systems with constant or variable flows where you want to optimize the setting of the pump duty point.
- Systems where summer setback is required (ALPHA2 15-55).

### **ALPHA2 26-99 and ALPHA1 26-99 applications**

ALPHA2 26-99 and ALPHA1 26-99 circulator pumps are designed for circulating liquids in heating and air-conditioning systems.

These circulators are equipped with a conduit box for easy installation of the power cable.

ALPHA2 26-99 models are internally controlled and are designed for systems with variable flow rates, where the pump is internally controlled via a user interface. Speed control can reduce power consumption considerably.

ALPHA1 26-99 models are externally controlled via a low-voltage 0-10 VDC signal by a system controller integrated in a boiler or a building management system. The pump will run at its minimum speed if no signal is present or the signal fails.

### **ALPHA 15-55 HWR-D applications**

The ALPHA HWR-D system is an on-command hot water recirculation system for use in domestic hot water applications. It provides optimal comfort by providing hot water instantly on demand.

## Features

### Features overview

Feature	ALPHA2 15-55	ALPHA1 15-55	ALPHA2 26-99	ALPHA1 26-99	ALPHA 15-55 HWR-D
For heating and cooling systems	✓	✓	✓	✓	-
For hot water recirculation systems	✓	✓	-	-	✓
Energy efficient permanent magnet motor	✓	✓	✓	✓	✓
Simple operating panel	✓	✓	✓	-	✓
External speed control via low voltage 0-10 VDC signal	-	-	-	✓	-
AUTO <i>Adapt</i> control mode automatically adjusts the performance	✓	-	✓	-	-
Three constant speed modes	✓	-	-	-	-
Three constant pressure modes	✓	✓	✓	-	-
Three proportional pressure settings	-	-	✓	-	-
Cast iron pump housing	✓	✓	✓	✓	-
Stainless steel pump housing	✓	✓	-	-	✓
LED display shows current energy consumption and estimated flow	✓	✓	-	-	-
Integrated check valve	✓	✓	✓	✓	✓
Line cord connection	✓	✓	-	-	✓
Terminal box connection	✓	✓	✓	✓	-
Max. head [ft (m)]	19 (5.8)	19 (5.8)	42 (12.8)	42 (12.8)	17 (5.1)
Max. flow [gpm (m <sup>3</sup> /h)]	21 (4.8)	21 (4.8)	26 (5.9)	26 (5.9)	16.5 (3.7)
Flanged connection for quick installation	✓	✓	✓	✓	-
1 1/4" NPSM (union) connection	-	-	-	-	✓
Nut captures for flanges	✓	✓	-	-	-
Magnetite-resistant design helps prevent deposits and blockages with robust ceramic shaft, ceramic bearing rings, and stainless steel bearing plate	✓	✓	✓	✓	✓
Manual summer mode starts the pump every 24 hours to protect against deposits	✓	-	-	-	-
Robust startup feature enables the pump to continuously attempt to restart in blocked rotor conditions	✓	✓	-	-	-
Foam insulating jacket for some models	✓	*	-	-	-
Replaces more than 30 other pump models	✓	✓	-	-	-
Bluetooth™ enabled wireless communication with accessories	-	-	-	-	✓

\* Available as an accessory for ALPHA1 15-55.

## Pumped liquids

Grundfos ALPHA circulators are suitable for the following liquids:

- clean, thin, non-aggressive and non-explosive liquids, not containing solid particles, fibers or mineral oil.
- cooling liquids, not containing mineral oil.
- domestic hot water with maximum 15 grain/gal (US), maximum 149 °F (65 °C); maximum peak 158 °F (70 °C).
- softened water.
- If the pump is installed in a heating system, the water must meet the requirements of accepted standards on water quality in heating systems.

For water with a higher degree of hardness, contact Grundfos.

ALPHA circulators must not be used for the transfer of flammable liquids such as diesel oil, gasoline or similar liquids, and must not be used to circulate aggressive liquids such as acid or seawater.

In domestic hot water systems, the temperature of the pumped liquid must always be above 122 °F (50 °C) due to the risk of legionella. The temperature of the hot water source must not be high enough to cause burns or scalding.

The pump must be permanently connected to the main water supply and must not be connected with a hose.

The kinematic viscosity of water is 1 mm<sup>2</sup>/s (1 cSt) at 68 °F (20 °C). If the pump is used for a liquid with a higher viscosity, the hydraulic performance of the pump will be reduced.

Example: 50 % glycol at 68 °F (20 °C) means a viscosity of approximately 10 mm<sup>2</sup>/s (10 cSt) and a reduction of the pump performance by approximately 15 %.

When selecting a pump, pay attention to the viscosity of the pumped liquid. Additives that can or will disturb the functionality of the pump must not be used.

### Glycol

The ALPHA 1/2 15-55 and ALPHA 26-99 circulators are designed for pumping clean water or up to 50/50 mixtures by weight of glycol and water.\*

To prevent the glycol mixture from degrading, temperatures exceeding the rated liquid temperature must be avoided, and the operating time at high temperatures must be minimized.

It is important to clean and flush the system before adding the glycol mixture.

To prevent corrosion or precipitation, the glycol mixture must be checked and maintained regularly. If further dilution of the supplied glycol is required, refer to the glycol supplier's instructions.

\* ALPHA 1/2 26-99, if cooling liquid is used, requires mixtures of water with anti-freezing media such as glycol or ethanol down to 14 °F (-10 °C) with a validated temperature profile. The viscosity increases depending on the type of glycol, the mixture, and the liquid temperature, but the viscosity must not exceed 10 cSt (10 mm<sup>2</sup>/s).

ALPHA HWR-D is suited for domestic hot water only.

## 2. Performance range

### ALPHA2 15-55 performance range and operating mode selection

The shown hydraulic performance is without a check valve.

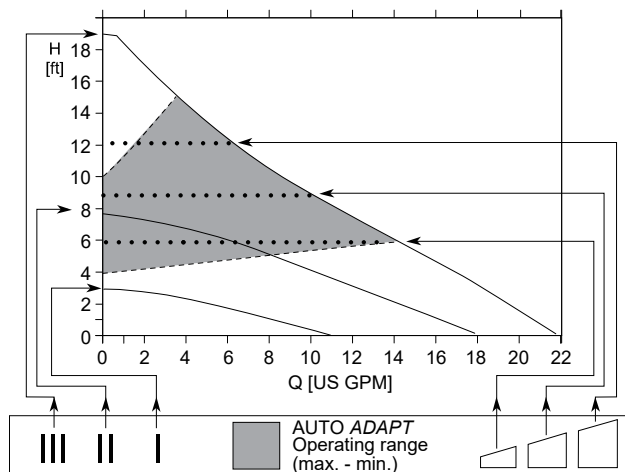

TM074554

#### Push-button

- Each time you press the push-button, the circulator setting is changed.



TM061857

#### High constant speed

- Runs at a constant speed and consequently on a constant curve.
- At Speed III, the pump is set on the maximum curve under all operating conditions.
- For quick venting, set the pump to Speed III for a short time.



TM073288

#### Medium constant speed

- Runs at a constant speed and consequently on a constant curve.
- At Speed II, the pump is set on the medium curve under all operating conditions.



TM073287

#### Low constant speed

- Runs at a constant speed and consequently on a constant curve.
- At Speed I, the pump is set on the minimum curve under all operating conditions.



TM073286

#### Constant pressure I

- The duty point of the pump will move left and right along the lowest constant-pressure curve depending on the water demand in the system.
- The pump head (pressure) is kept constant, irrespective of the water demand.



TM072406

#### Constant pressure II

- The duty point of the pump will move left and right along the middle constant-pressure curve depending on the water demand in the system.
- The pump head (pressure) is kept constant, irrespective of the water demand.



TM072407

#### Constant pressure III

- The duty point of the pump will move left and right along the highest constant-pressure curve depending on the water demand in the system.
- The pump head (pressure) is kept constant, irrespective of the water demand.



TM072408

#### AUTOAdapt (factory setting)

- This function automatically controls the pump performance within the defined performance range, automatically adjusting the pump performance to system demands over time.



TM061858

#### Manual summer mode

- The pump is stopped to save energy, and only the electronics are running.
- To avoid liming and blocking of the pump, the pump is started every 24 hours for two minutes at a low speed.



TM061857

(Hold for three seconds)



## ALPHA1 15-55 performance range and operating mode selection

The shown hydraulic performance is without a check valve.

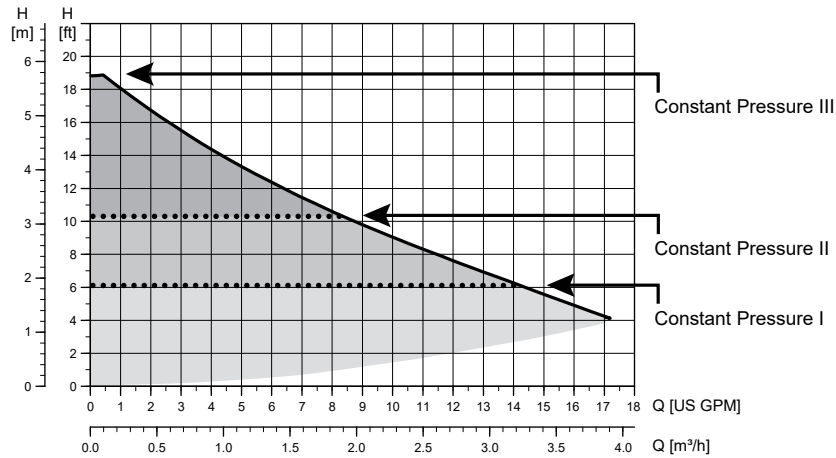

TM068910

### Push-button

- Each time you press the push-button, the circulator setting is changed.



TM061857

### Constant pressure I

- The duty point of the pump will move left and right along the lowest constant-pressure curve depending on the water demand in the system.
- The pump head (pressure) is kept constant, irrespective of the flow demand.



TM073286

### Constant pressure II

- The duty point of the pump will move left and right along the middle constant-pressure curve depending on the water demand in the system.
- The pump head (pressure) is kept constant, irrespective of the flow demand.



TM073287

### Constant pressure III

- The duty point of the pump will move left and right along the highest constant-pressure curve depending on the water demand in the system.
- The pump head (pressure) is kept constant, irrespective of the flow demand.



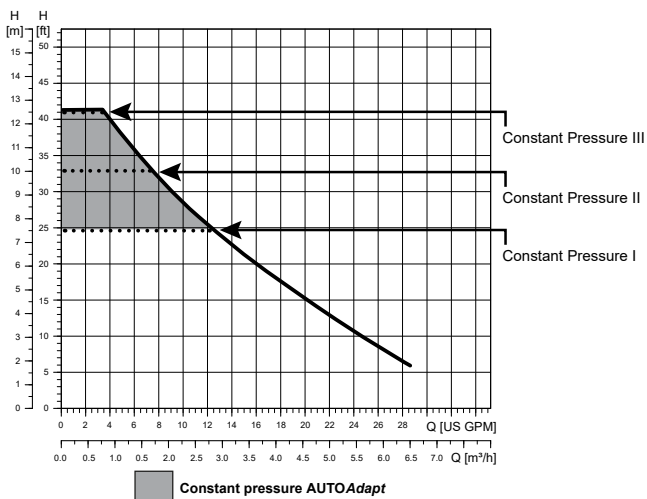
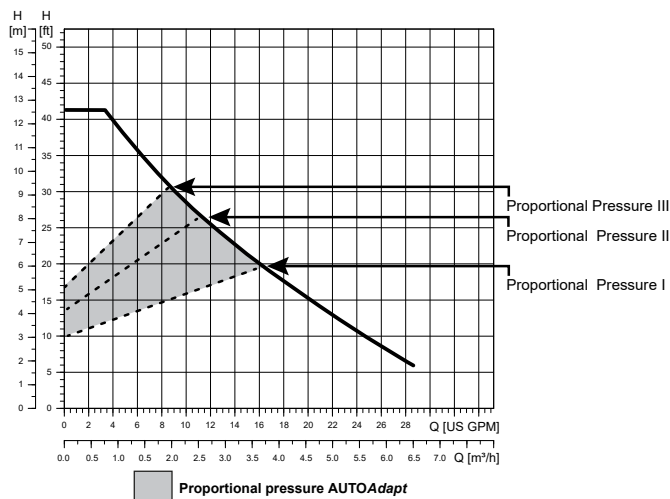

TM073288

### ALPHA2 26-99 performance range



TM074500

<b>Push-button</b>	<ul style="list-style-type: none"> <li>Each time you press the push-button, the circulator setting is changed.</li> </ul>		TM061857
<b>Proportional pressure I</b>	<ul style="list-style-type: none"> <li>The duty point of the pump will move up or down along the lowest proportional-pressure curve, depending on the heat demand in the system.</li> <li>The pump head (pressure) is reduced at falling heat demand and increased at rising flow demand.</li> </ul>	I	TM073286
<b>Proportional pressure II</b>	<ul style="list-style-type: none"> <li>The duty point of the pump will move up or down along the middle proportional-pressure curve, depending on the heat demand in the system.</li> <li>The pump head (pressure) is reduced at falling heat demand and increased at rising flow demand.</li> </ul>	II	TM073287
<b>Proportional pressure III</b>	<ul style="list-style-type: none"> <li>The duty point of the pump will move up or down along the highest proportional-pressure curve, depending on the heat demand in the system.</li> <li>The pump head (pressure) is reduced at falling heat demand and increased at rising flow demand.</li> </ul>	III	TM073288
<b>Proportional pressure AUTOAdapt</b>	<ul style="list-style-type: none"> <li>This function enables the circulator to control the pump performance automatically within the defined proportional pressure range and automatically adjusts the pump performance to system demands over time.</li> </ul>		TM061858
<b>Constant pressure I</b>	<ul style="list-style-type: none"> <li>The duty point of the pump will move left and right along the lowest constant-pressure curve depending on the flow demand in the system.</li> <li>The pump head (pressure) is kept constant, irrespective of the flow demand.</li> </ul>	I	TM073286
<b>Constant pressure II</b>	<ul style="list-style-type: none"> <li>The duty point of the pump will move left and right along the middle constant-pressure curve depending on the flow demand in the system.</li> <li>The pump head (pressure) is kept constant, irrespective of the flow demand.</li> </ul>	II	TM073287
<b>Constant pressure III</b>	<ul style="list-style-type: none"> <li>The duty point of the pump will move left and right along the highest constant-pressure curve depending on the flow demand in the system.</li> <li>The pump head (pressure) is kept constant, irrespective of the flow demand.</li> </ul>	III	TM073288
<b>Constant pressure AUTOAdapt</b>	<ul style="list-style-type: none"> <li>This function enables the circulator to control the pump performance automatically within the defined constant pressure range and automatically adjusts the pump performance to system demands over time.</li> </ul>		TM061859

**ALPHA1 26-99 performance range**

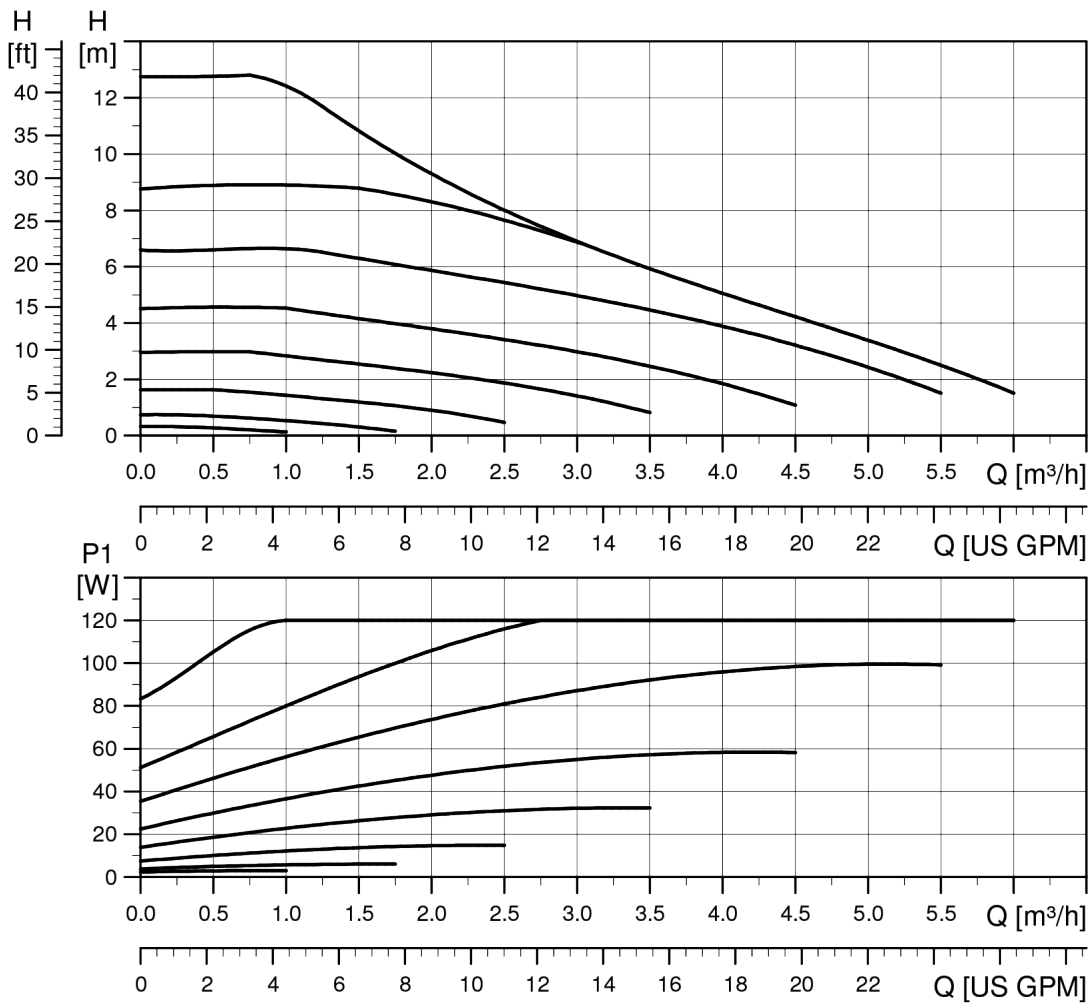

ALPHA1 26-99 circulators are externally speed-controlled by an analog 0-10 VDC signal.

TM073788

## ALPHA 15-55 HWR-D performance range

The pump runs at a constant speed and consequently on a constant curve. The pump is set on the maximum curve under all operating conditions.

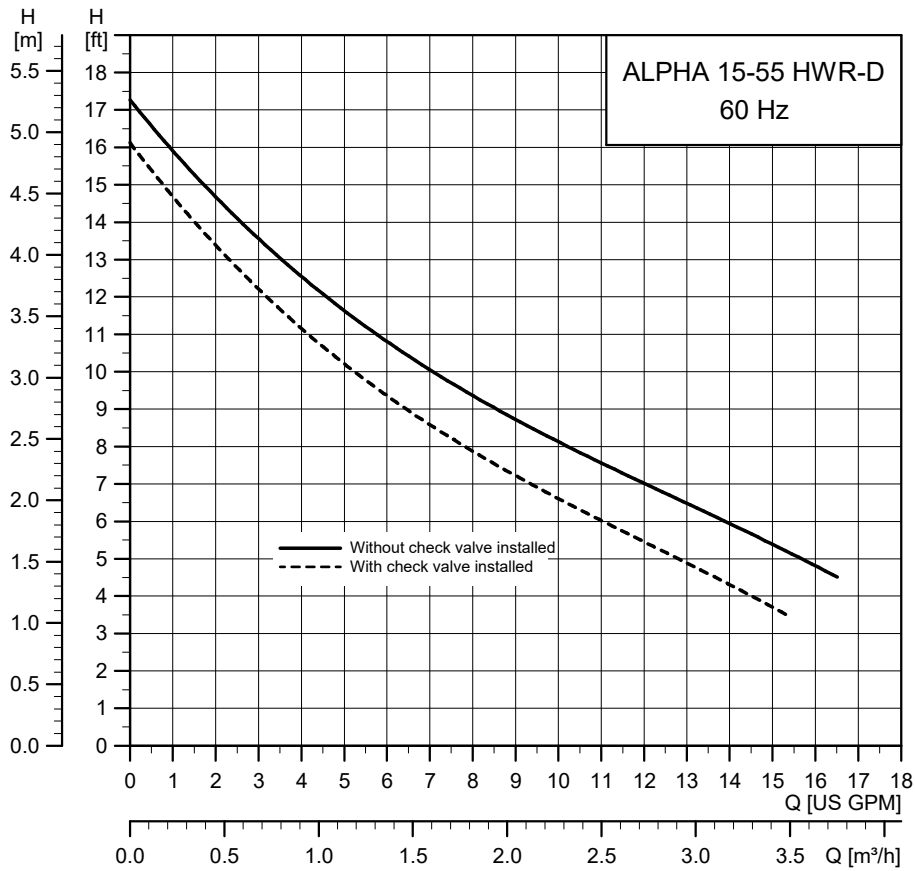

TM072501

## 3. Product range

### Product range

#### ALPHA2 15-55

Model	Description	Product number
ALPHA2 15-55 F	Cast iron flange with terminal box	99163903
ALPHA2 15-55 FR	Cast iron rotated flange with terminal box	99163932
ALPHA2 15-55 SF	Stainless flange with terminal box	99163937
ALPHA2 15-55 F/LC	Cast iron flange with line cord	99163906
ALPHA2 15-55 FR/LC	Cast iron rotated flange with line cord	99163934
ALPHA2 15-55 SF/LC	Stainless flange with line cord	99163972

#### ALPHA1 15-55

Model	Description	Product number
ALPHA1 15-55 F	Cast iron flange with terminal box	99287256
ALPHA1 15-55 FR	Cast iron rotated flange with terminal box	99287259
ALPHA1 15-55 SF	Stainless flange with terminal box	99287262
ALPHA1 15-55 F/LC	Cast iron flange with line cord	99285998
ALPHA1 15-55 FR/LC	Cast iron rotated flange with line cord	99287244
ALPHA1 15-55 SF/LC	Stainless flange with line cord	99287250

#### ALPHA2 26-99

Model	Description	Product number
ALPHA2 26-99 F	Cast iron flange with terminal box	99490916
ALPHA2 26-99 SF	Stainless flange with terminal box	99490917

#### ALPHA1 26-99

Model	Description	Product number
ALPHA1 26-99 F	Cast iron flange with terminal box	99490914

#### ALPHA 15-55 HWR-D

Model	Description	Product number
ALPHA 15-55 HWR-D LC CA	HWR-D system with: <ul style="list-style-type: none"> <li>• Pump with line cord</li> <li>• Push-button HWR-D (qty. 2)</li> <li>• Temperature sensor HWR-D</li> </ul>	99472723
ALPHA 15-55 HWR-D LC	<ul style="list-style-type: none"> <li>• Pump with line cord</li> <li>• Push-button HWR-D (qty. 2)</li> </ul>	99472724
Push button HWR-D	Push-button HWR-D only (qty. 1)	99410378
Temperature sensor HWR-D	Temperature sensor HWR-D only (qty. 1)	99410350
Repeater HWR-D	Repeater HWR-D only (qty. 1)	99410217

## Competitor cross reference

### ALPHA2 15-55

Model	Grundfos	TACO	B&G	Armstrong	WILO
ALPHA2 15-55 F/LC	UP 15-10 F	005-F2-3	NRF-25	Astro 230CI-R	Star S 16FX
	UP 15-42 F	006-F7	NRF-9F/LW	Astro 250CI-R	Star S 21FX
	UPS 15-42 F	007-F5-5	Ecocirc 19-14 vario	Compass 20-20	Star S 21RFC
	UPS 15-58 FC	008-F6-1	Ecocirc 19-14 auto		Stratos ECO 16 RFC
	ALPHA 15-55 F	008-F6-3			
		00R-F6-1			
ALPHA2 15-55 FR/LC	UP 15-10 FR	005-F2-2	NRF-22	Astro 230CI	Star S 16F
	UP 15-42 FR	007-F5	NRF-9F/LW	Astro 250CI	Star S 21F
	UPS15-58 FRC	008-F6		Astro 20	Star S 21RFC
	ALPHA 15-55 FR	00R-MSF		Astro 25	Stratos ECO 16 RFC
		0015-MSF3		Astro 30	
		007e			
	0015e				

### ALPHA1 15-55

Model	Grundfos	TACO	B&G	Armstrong	WILO
ALPHA1 15-55	UP 15-10 F	005-F2-3	NRF-9F/LW	Astro 20	Star S 16FX
	UP 15-42 F	006-F7	NRF-22	Astro 25	Star S 21FX
	UPS 15-42 F	007-F5-5	NRF-25	Astro 30	Star S 21RFC
	UPS 15-58 FC	008-F6-1	NRF-9F/LW	Astro 230CI-R	Stratos ECO 16 RFC
		008-F6-3	Ecocirc 19-14 vario	Astro 250CI-R	
		00R-F6-1	Ecocirc 19-14 auto	Compass 20-20	
		00R-MSF			
		0015-MSF3-1			
		007e			
	0015e				

### ALPHA2 26-99

Model	Grundfos	TACO	B&G	Armstrong	WILO
ALPHA2 26-99	UPS 26-99F	0011-F4, VR3452	Ecocirc XL		

## 4. Identification

### Nameplates

#### Nameplate, ALPHA2 and ALPHA1

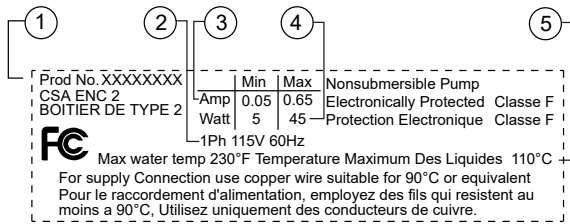

Fig. Example of nameplate, ALPHA2

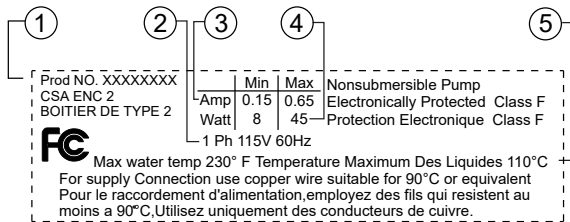

Fig. Example of nameplate, ALPHA1

Pos.	Description
1	Product number
2	Voltage [V]
3	Rated current [A]
	• Min.: Minimum current [A]
	• Max.: Maximum current [A]
4	Input power [W]:
	• Min.: Minimum power [W]
	• Max.: Maximum power [W]
5	Maximum fluid temperature [°F]

#### Nameplate, ALPHA 26-99 models

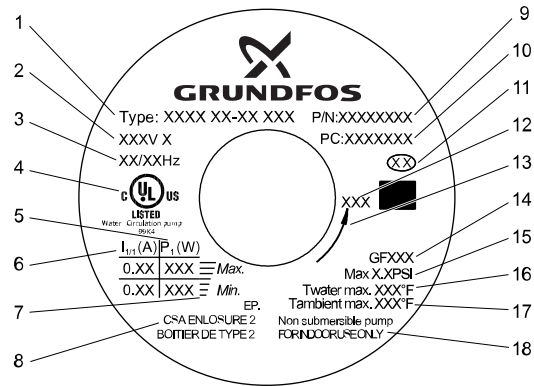
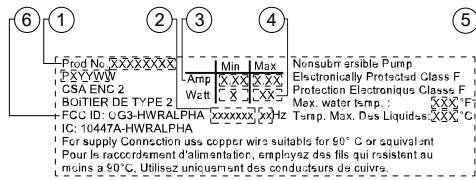

Fig. Example of faceplate, ALPHA 26-99

Pos.	Description
1	Type designation
2	Voltage [V]
3	Frequency [Hz]
4	Approval mark UL
5	Input power P1 [W] at a maximum and minimum performance
6	Rated current [A] at maximum and minimum performance
7	Speed
8	Enclosure class
9	Product number
10	Production code (YYMM)
11	Country of origin
12	Control signal
13	Direction of rotation
14	Code for UL Listed pumps
15	Max. system pressure [psi]
16	Max. water temperature [°F]
17	Max. ambient temperature [°F]
18	Application

## Nameplate, ALPHA 15-55 HWR-D models



TM074591

Fig. Example of nameplate, ALPHA 15-55 HWR-D models

Pos.	Description
1	Product number
2	Voltage [V]
3	Rated current [A]:
	• Min.: Minimum current [A] • Max.: Maximum current [A]
4	Input power [W]
	• Min.: Minimum power [W] • Max.: Maximum power [W]
5	Maximum liquid temperature [°F]
6	FCC and IC ID

## Type keys

### Type key, ALPHA 2

Example: ALPHA2 15-55 - 165

Code	Explanation
ALPHA2	Pump type
15	Nominal diameter (DN) of inlet and outlet ports [mm]
55	Maximum head [dm]
-	- : Cast iron pump housing N : Stainless steel pump housing
165	Port-to-port length [mm]

### Type key, ALPHA 1

Example: ALPHA1 15-55 F

Code	Explanation
ALPHA1	Pump type
15	Nominal diameter (DN) of inlet and outlet ports [mm]
55	Maximum head [dm]
F	Pipe connection F: Flange

## Type key, ALPHA 26-99 models

Example: ALPHA2 26-99 FC

Code	Description
ALPHA	Pump range (ECM circulator)
26-99	Pump control
	1: Externally controlled (0-10 V)
	2: Internally pressure-controlled modes
	- Proportional pressure - Constant pressure - Proportional pressure with <i>AUTOAdapt</i> - Constant pressure with <i>AUTOAdapt</i>
F	Pump name
	Material
	: Cast iron S: Stainless steel
C	Connection
	F: Flange Check valve (removable)

## Type key, ALPHA 15-55 HWR-D models

Example: ALPHA 15-55 HWR-D

Code	Explanation
ALPHA	Pump type
15	Nominal diameter (DN) of inlet and outlet ports [mm]
55	Maximum head [dm]
HWR-D	Hot water recirculation on demand system



## 5. Operation

### Operating conditions

#### Operating conditions, ALPHA2 15-55 and ALPHA1 15-55 models

##### Supply voltage

1 x 115 V, + 10 %/- 10 %, 60 Hz

##### Motor protection

The pump requires no external motor protection.

##### Enclosure class

Indoor use only, IP42.

CSA enclosure type 2.

##### Insulation class

F

##### Relative humidity

Maximum 95 %

##### Maximum outlet pressure

150 psi (10.34 bar)

##### Inlet pressure

Liquid temp.	Min. inlet press.
[°F (°C)]	[psi (bar)]
167 (75)	0.75 (0.05)
194 (90)	4.06 (0.28)
230 (110)	15.7 (1.08)

##### Sound pressure level

43 dB (A)

##### Ambient temperature

32 °F (0 °C) to 104 °F (40 °C)

##### Liquid temperature

36 °F (2 °C) to 230 °F (110 °C)

In domestic hot water systems, keep the liquid temperature below 149 °F (65 °C) to eliminate the risk of lime precipitation.

To avoid condensation in the control box and stator, the liquid temperature must always be higher than the ambient temperature:

Ambient temp.	Min. liquid temp.	Max. liquid temp.
[°F (°C)]	[°F (°C)]	[°F (°C)]
32 °F (0 °C)	36 °F (2 °C)	230 °F (110 °C)
50 °F (10 °C)	50 °F (10 °C)	230 °F (110 °C)
68 °F (20 °C)	68 °F (20 °C)	230 °F (110 °C)
86 °F (30 °C)	86 °F (30 °C)	230 °F (110 °C)
95 °F (35 °C)	95 °F (35 °C)	194 °F (90 °C)
104 °F (40 °C)	104 °F (40 °C)	158 °F (70 °C)

##### Watt readings

Accuracy: ± 1 watt.

##### Flow indicator

Provides a relative indication of flow – should not be used in lieu of a flow meter.

##### Check valve

Use of a check valve may reduce pump hydraulic performance. Use a check valve in parallel pumping applications.

##### Approximate power usage, ALPHA2 15-55

Speed setting	Min. [W]	Max. [W]
Constant speed III (High)	39	45
Constant speed II (Medium)	15	30
Constant speed I (Low)	5	8
Constant pressure I	8	45
Constant pressure II	14	45
Constant pressure III	22	45
AUTOAdapt	5	45

##### Approximate power usage, ALPHA1 15-55

Speed setting	Min. [W]	Max. [W]
Constant pressure III	39	45
Constant pressure II	14	45
Constant pressure I	8	45

## Operating conditions, ALPHA2 26-99 and ALPHA1 26-99 models

### Supply voltage

1 x 115 V, + 10 %/- 10 %, 60 Hz

### Motor protection

EP - Electronically Protected.

The pump requires no external motor protection.

### Enclosure class

CSA enclosure type 2. Indoor use only. X2D.

### Insulation class

F

### Relative humidity

Maximum 95 %

### Maximum system pressure

150 psi (10 bar) (1.0 MPa)

### Inlet pressure

The minimum inlet pressure must be available at the pump inlet during operation.

Liquid temp.	Min. inlet press.
[°F (°C)]	[psi (bar) (MPa)]
203 (95)	> 7 (0.48) (0.05)

### Sound pressure level

43 dB(A)

### Inrush current

Measured on a flicker network according to IEC 61000-3-3:1994 + A1, + A2, Annex B.

- 115 V: 25.2 A

### Leakage current

< 3.5 mA

### Ambient temperature

Maximum 130 °F (55 °C) near the pump surface.

### Storage temperature

Maximum 158 °F (70 °C)

### Liquid temperature

Maximum (continuously): 203 °F (95 °C)

Minimum: 14 °F (-10 °C)

In domestic hot water systems, keep the liquid temperature below 149 °F (65 °C) to eliminate the risk of lime precipitation.

To avoid condensation in the control box and stator, the liquid temperature must always be higher than the ambient temperature.

Operating temperatures		
Ambient temp.	Liquid temp. min.	Liquid temp. max.
[°F (°C)]	[°F (°C)]	[°F (°C)]
32 (0)	36 (2)	230 (110)
50 (10)	50 (10)	230 (110)
68 (20)	68 (20)	230 (110)
86 (30)	86 (30)	230 (110)
95 (35)	95 (35)	194 (90)
104 (40)	104 (40)	158 (70)

### Check valve

Use of a check valve may reduce pump hydraulic performance. Use a check valve in parallel pumping applications.

### Approximate power usage

Approx. power usage		
Speed setting	Min. [W]	Max. [W]
Constant pressure (I)	8	45
Constant pressure (II)	14	45
Constant pressure (III)	39	45

## Operating conditions, ALPHA 15-55 HWR-D models

### Supply voltage

1 x 115 V, + 10 %/- 10 %, 60 Hz

### Motor protection

The pump requires no external motor protection.

### Enclosure class

Indoor use only, IP42.

CSA enclosure type 2.

### Insulation class

F

### Relative humidity

Maximum 95 %

### Maximum outlet pressure

150 psi (10.34 bar)

### Inlet pressure

Liquid temp.	Min. inlet press.
[°F (°C)]	[psi (bar)]
167 (75)	0.75 (0.05)
194 (90)	4.06 (0.28)
230 (110)	15.7 (1.08)

### Sound pressure level

43 dB (A)

### Ambient temperature

32 °F (0 °C) to 104 °F (40 °C)

### Liquid temperature

36 °F (2 °C) to 230 °F (110 °C)

In domestic hot water systems, keep the liquid temperature below 149 °F (65 °C) to eliminate the risk of lime precipitation.

To avoid condensation in the control box and stator, the liquid temperature must always be higher than the ambient temperature:

Ambient temp.	Min. liquid temp.	Max. liquid temp.
[°F (°C)]	[°F (°C)]	[°F (°C)]
32 (0)	36 (2)	230 (110)
50 (10)	50 (10)	230 (110)
68 (20)	68 (20)	230 (110)
86 (30)	86 (30)	230 (110)
95 (35)	95 (35)	194 (90)
104 (40)	104 (40)	158 (70)

### Check valve

Use of a check valve may reduce pump hydraulic performance.

### Approximate power usage

Min. [W]	Max. [W]
39	45

## Control modes

### Control modes, ALPHA2

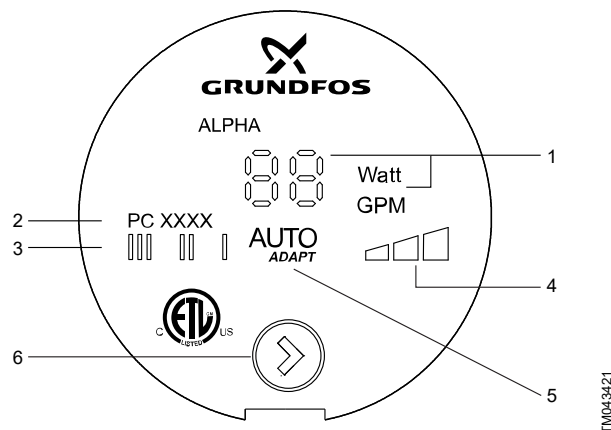

Fig. Elements on the ALPHA2 user interface

Pos.	Description
1	Display showing the power consumption in watt or the flow Light field indicating high and low flow
2	Production code: - 1st and 2nd figures, year - 3rd and 4th figures, week
3	Light field indicating fixed speed setting
4	Light field indicating constant pressure setting
5	Light field indicating AUTOAdapt setting
6	Push-button for selection of pump setting

#### Display

The display is on when you have switched on the power supply. The display shows the actual pump power consumption in watt (integer) or the actual flow during operation. If a fault is indicated after the fault is corrected, the pump is reset by switching the power supply off and on. If the pump impeller is rotated, for example, when filling the pump with water, sufficient energy can be generated to light up the display even if the power supply has been switched off.

#### Light field indicating high and low flow:

- The light field blinks for low flow. If the flow is lower than 1 gpm, the light field flashes randomly between "0" and "1".
- The light field shows "HI" for high flow. If the flow is higher than 12 gpm, the light field shows "HI" on the user interface.

#### Light fields indicating the pump setting:

- The pump has optional control modes with different settings which are selected with the push-button. The pump setting is indicated by light fields in the display.

#### Setting the pump

**AUTOAdapt, factory default setting** - The pump's factory default setting is the AUTOAdapt setting. The setting can be changed from the recommended factory default setting to an alternative setting by pressing the pump's push-button.

**Changing from recommended to alternative pump setting** - Heating systems are "slow" systems that cannot be set to the optimum operation within minutes or hours. However, if the recommended pump setting in some applications does not give the desired distribution of heat in the rooms of the house, you can change to an alternative pump setting.

#### Selection of control mode by application

Application	ALPHA2 control mode
Floor heating	Constant pressure
Two-pipe system	AUTOAdapt
Ventilation	Speed 1, 2 or 3
Boiler shunt	Speed 1, 2 or 3
One-pipe system	Speed 1, 2 or 3 or constant pressure
Domestic hot water	Speed 1, 2 or 3

#### ALPHA2 AUTOAdapt mode

The AUTOAdapt mode adjusts the pump performance to the actual heat demand in the system. As the performance is adjusted gradually, we recommend that you leave the pump in the AUTOAdapt mode for at least one week before changing the pump setting. If you choose to change back to AUTOAdapt, the pump remembers its last setpoint in AUTOAdapt and resumes the automatic adjustment of the performance.

#### ALPHA2 constant pressure modes

In this control mode, the constant differential pressure across the pump is maintained, irrespective of the flow.

#### ALPHA2 constant speed modes (III, II, or I)

In this control mode, the pump runs at a constant speed and consequently on a constant curve.

- At speed III, the pump is set on the maximum curve under all operating conditions. You can quickly vent the pump by setting the pump to speed III for a short period.
- At speed II, the pump is set on the medium curve under all operating conditions.
- At speed I, the pump is set on the minimum curve under all operating conditions.

#### ALPHA2 manual summer mode

In this control mode, the pump is stopped to save energy, and only the electronics are running. To avoid lime deposit that could block the pump, the pump is started every 25 hours for two minutes at a low speed. This is an alternative to shutting down the pump if there is a risk of lime deposit.

The display is turned off. If any faults occur during manual summer mode, the display will show the faults when the pump is taken out of manual summer mode.

If any alarms occur during manual summer mode, no alarms will be shown. When manual summer mode is deactivated again, only the actual alarms will be displayed.

To activate manual summer mode, press and hold the push-button for three seconds. All light fields will turn off, and the pump will stop. The *AUTOAdapt* light field will flash for four seconds.

To deactivate manual summer mode, press the push-button to return to normal operation.

## Control modes, ALPHA1

Fig. Elements on the ALPHA1 user interface

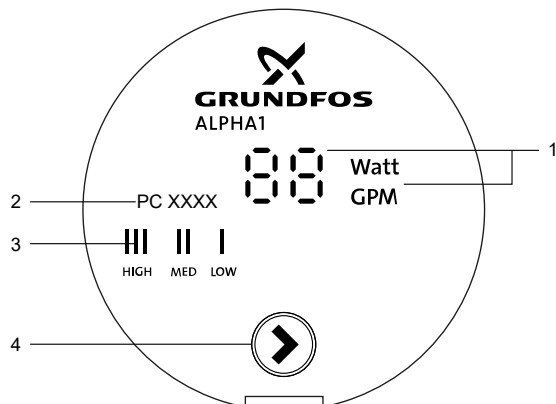

TM068878

Pos.	Description
1	Display showing the power consumption in watt or the flow
	Light field indicating high and low flow
2	Production code:
	- 1st and 2nd figures, year
	- 3rd and 4th figures, week
3	Light field indicating constant pressure setting
4	Push-button for selection of pump setting

### Display

The display is on when you have switched on the power supply. The display shows the actual pump power consumption in watt (integer) or the actual flow during operation. If a fault is indicated after the fault is corrected, the pump is reset by switching the power supply off and on. If the pump impeller is rotated, for example, when filling the pump with water, sufficient energy can be generated to light up the display even if the power supply has been switched off.

#### Light field indicating high and low flow:

- The light field blinks for low flow. If the flow is lower than 1 gpm, the light field flashes randomly between "0" and "1".
- The light field shows "HI" for high flow. If the flow is higher than 12 gpm, the light field shows "HI" on the control panel.

#### Light fields indicating the pump setting:

- The pump has optional control modes with different settings which are selected with the push-button. The pump setting is indicated by light fields in the display.

### Setting the pump

You can change the pump setting by pressing the push-button.

**Constant Pressure III, factory default setting** - The pump's factory default setting is the Constant Pressure III setting. In this control mode, a constant differential pressure

across the pump is maintained irrespective of the flow. The setting can be changed from the recommended factory default setting to an alternative setting by pressing the pump's push-button.

#### Changing from recommended to alternative pump setting

- Heating systems are "slow" systems that cannot be set to the optimum operation within minutes or hours. However, if the recommended pump setting in some applications does not give the desired distribution of heat in the rooms of the house, you can change to an alternative pump setting.

## Control modes, ALPHA2 26-99

### Internally controlled

ALPHA2 26-99 circulator pumps are designed for systems with variable flow rates, where the pump is internally controlled via a user interface.

ALPHA2 26-99 circulator pumps automatically control the differential pressure by adjusting the pump performance to the actual heat demand without the use of external components. Two different control modes are available:

#### Proportional pressure

- Proportional pressure with the differential pressure increasing at increased flow.



TM073148

**Fig.** Proportional pressure

#### Constant pressure

- Constant pressure with the differential pressure kept constant.



TM073147

**Fig.** Constant pressure

#### Grundfos AUTOAdapt

The Grundfos *AUTOAdapt* function enables the circulator to control the pump performance automatically within a defined performance range:

- Adjusting the pump performance to the size of the system.
- Adjusting the pump performance to the variations in load over time.

Two different control modes are available for Grundfos *AUTOAdapt*:

- **Proportional Pressure *AUTOAdapt*.** In proportional pressure *AUTOAdapt*, the circulator is set to proportional-pressure control.



TM073146

**Fig.** Proportional Pressure *AUTOAdapt*

- **Constant Pressure *AUTOAdapt*.** In constant pressure *AUTOAdapt*, the circulator is set to constant pressure control.



TM073145

**Fig.** Constant Pressure *AUTOAdapt*

## Control modes, ALPHA 15-55 HWR-D models

Fig. LED symbols and buttons on the pump display

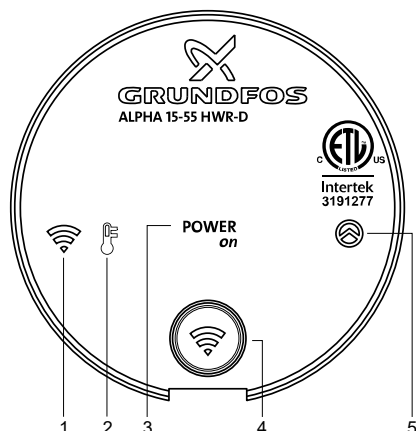

TM072147

Pos.	Description
1	"Connect" LED
2	"Temperature sensor" LED
3	"Power ON" LED
4	Pairing button
5	"Pump operation" LED

Pump display symbol	Status	Explanation
"Power ON"	Green	Lights green when the pump is powered on.
"Connect"	Flashing blue	The symbol flashes blue when the pump is ready for pairing with the push-button or temperature sensor. The symbol flashes blue when a paired temperature sensor has been disconnected.
"Connect"	Blue	The symbol lights blue for 5 seconds when pairing is successful between the pump and the push-button or temperature sensor.
"Connect"	Flashing red (5 seconds) during installation	The symbol flashes red for 5 seconds when pairing has failed with the push-button or temperature sensor.
"Connect"	Flashing red (2 seconds) during normal operation	The symbol flashes red for 2 seconds when the battery level in the push-button is at a critical level. Replacement of the batteries in the push-button is recommended.
"Connect"	Green	The icon lights green for 2 seconds when the push-button is activated during normal operation.
"Pump operation"	Green	The symbol lights green when the pump circulates water during normal operation and is connected to the temperature sensor.
"Pump operation"	Yellow	The symbol lights yellow when the pump has timed out. The pump does not circulate water.
"Pump operation"	Red	The pump is in an alarm state (see fault finding section in the installation and operating instructions).

Pump display symbol	Status	Explanation
"Temperature"	Red	The symbol lights red when the battery level in the temperature sensor is at a critically low level (see fault finding section in the installation and operating instructions). Replace the batteries in the temperature sensor.

### Temperature sensor HWR-D LED

The LED is located on the temperature sensor beneath the lid. You must remove the lid in order to pair the temperature sensor with the pump.

Status	Explanation
Flashing blue	The LED flashes blue when the temperature sensor is ready for pairing with the pump.
Blue	The LED lights blue for 5 seconds when pairing between the temperature sensor and the pump has succeeded.
Flashing red (5 seconds) during installation	The LED flashes red for 5 seconds when pairing between the temperature sensor and the pump has failed. Restart the installation procedure.

### Push-button HWR-D LED

LED status	Explanation
Flashing blue	The LED flashes blue when the push-button is ready for pairing with the pump.
Blue	The LED lights blue for 5 seconds when pairing between the push-button and the pump has succeeded.
Flashing red (5 seconds) during installation	The LED flashes red for 5 seconds when pairing between the push-button and the pump has failed. Restart the installation procedure.
Flashing red (2 seconds) during normal operation	The LED flashes red for 2 seconds when the battery level in the push-button is at a critical level and the push-button is activated. Replacement of the batteries in the push-button is recommended.
Green	The LED lights green for 2 seconds when the push-button is activated during normal operation.

### Repeater HWR-D LED

The LED on the repeater will light green when the repeater is in operation.



## 6. Technical data

### Technical data, ALPHA2 15-55

Flow (Q)	0 - 21.5 gpm (0 - 4.9 m <sup>3</sup> /h)
Head (H)	0 - 19 ft (0 - 5.8 m)
Supply voltage	1 x 115 V, + 10 %/- 10 %, 60 Hz
Motor	4-pole, synchronous permanent magnet motor. The pump requires no external motor protection.
Power usage (approximate)	5 - 45 W
Watt readings	Accuracy: ± 1 watt
Amps	Max. 0.65 A
Horsepower	0.06 hp
Capacitor	-
Enclosure class	Indoor use only, IP42. CSA enclosure type 2.
Liquid temperature	36 to 230 ° F (2 to 110 °C)*
Relative humidity	Max. 95 %
Ambient temp.	32 to 104 °F (0 to 40 °C)*
Insulation class	F
Max. system pressure	Max. 150 psi (10 bar)
Max. outlet pressure	Max. 150 psi (10 bar)
Sound pressure level	43 dB (A)
Approvals	ETL, NSF/ANSI 61, NSF/ANSI 372, FCC, Canadian ICES-003. Complies to limits for class B digital device, pursuant to Part 15 of the FCC Rules.
Flange-to-flange length	6.5 in (165 mm)
Pump housing	Cast iron or stainless steel.
Connection type	Flanged.
Systems	Closed (F, FR) and open (SF).
Glycol	Maximum glycol concentrations with clean water: 50 % glycol @ 36 °F (2 °C). Hydraulic performance change can be expected.
Flow indicator	Provides a relative indication of flow – should not be used in lieu of a flow meter.
Check valve	Use of a check valve may reduce pump hydraulic performance (up to - 10 %). Use a check valve in parallel pumping applications.
Curve conditions	Test liquid: Airless water.**

\* See operating temperatures table. In domestic hot water systems, keep the liquid temperature below 149 °F (65 °C) to eliminate the risk of lime precipitation. To avoid condensation in the control box and stator, the liquid temperature must always be higher than the ambient temperature.

\*\* Curves apply to a density of 983.2 kg/m<sup>3</sup> and a liquid temperature of 140 °F (60 °C). All curves show average values and should not be used as guarantee curves. If a

specific minimum performance is required, individual measurements must be made. Curves apply to a kinematic viscosity of 0.474 cSt.

## Technical data, ALPHA1 15-55

ALPHA1	
Flow (Q)	0 - 17 gpm (0 - 3.9 m <sup>3</sup> /h)
Head (H)	0 - 19 ft (0 - 5.8 m)
Supply voltage	1 x 115 V, + 10 %/- 10 %, 60 Hz
Motor	4-pole, synchronous permanent magnet motor. The pump requires no external motor protection.
Power usage (approximate)	8 - 45 W
Watt readings	Accuracy: ± 1 watt.
Amps	Max. 0.65 A
Horsepower	0.06 Hp
Capacitor	-
Enclosure class	Indoor use only, IP42. CSA enclosure type 2.
Liquid temperature	36 to 230 ° F (2 to 110 °C)*
Relative humidity	Max. 95 %
Ambient temp.	32 to 104 °F (0 to 40 °C)*
Insulation class	F
Max. system pressure	Max. 150 psi (10 bar)
Max. outlet pressure	Max. 150 psi (10 bar)
Sound pressure level	43 dB (A)
Approvals	ETL, NSF/ANSI 61, NSF/ANSI 372, FCC, Canadian ICES-003. Complies to limits for class B digital device, pursuant to Part 15 of the FCC Rules.
Flange-to-flange length	6.5 in (165 mm)
Pump housing	Cast iron or stainless steel.
Connection type	Flanged.
Systems	Closed (F, FR) and open (SF).
Glycol	Maximum glycol concentrations with clean water: 50 % glycol @ 36 °F (2 °C). Hydraulic performance change can be expected.
Flow indicator	Provides a relative indication of flow – should not be used in lieu of a flow meter.
Check valve	Use of a check valve may reduce pump hydraulic performance (up to - 10 %). Use a check valve in parallel pumping applications.
Curve conditions	Test liquid: Airless water.**

\* See operating temperatures table. In domestic hot water systems, keep the liquid temperature below 149 °F (65 °C) to eliminate the risk of lime precipitation. To avoid condensation in the control box and stator, the liquid temperature must always be higher than the ambient temperature.

\*\* Curves apply to a density of 983.2 kg/m<sup>3</sup> and a liquid temperature of 140 °F (60 °C). All curves show average values and should not be used as guarantee curves. If a specific minimum performance is required, individual measurements must be made. Curves apply to a kinematic viscosity of 0.474 cSt.

## Technical data, ALPHA 26-99 models

ALPHA 26-99 models	
Flow (Q)	0 - 26 gpm (0 - 5.9 m <sup>3</sup> /h)
Head (H)	0 - 42 ft (0 - 12.8 m)
Supply voltage	1 x 115 V, + 10 %/- 10 %, 60 Hz
Power usage (approximate)	3 - 120 W
Amps	Max. 1.7 A
Horsepower	0.16 hp
Capacitor	µF
Enclosure class	Type 2. Indoor use only. X2D.
Liquid temperature	Max. (continuously): 203 °F (95 °C)
	Min.: 14 °F (-10 °C)
Relative humidity	Max. 95 %
Ambient temp.	Max. 130 °F (55 °C) near the pump surface.
Storage temp.	Max. 158 °F (70 °C)
Insulation class	F
Max. system pressure	Max. 150 psi (10 bar) (1.0 MPa)
Max. outlet pressure	Max. 150 psi (10 bar)
Approvals	cULus Listed; cULus Classified, Water Quality, Drinking water system component; NSF/ANSI 61/ MH26400/NSF/ANSI 372.
Flange-to-flange length	6.5 in (165 mm)
Pump housing	Cast iron or stainless steel.
Connection type	Flanged.
Glycol	Maximum glycol concentrations with clean water: 50 % glycol @ 36 °F (2 °C). Hydraulic performance change can be expected.
Check valve	Use of a check valve may reduce pump hydraulic performance (up to - 10 %). Use a check valve in parallel pumping applications.
Curve conditions	Test liquid: Airless water.**
Inrush current	Measured on a flicker network according to IEC 61000-3-3:1994 + A1, + A2, Annex B. 115 V: 25.2 A.
Leakage current	< 3.5 mA

\* See operating temperatures table. In domestic hot water systems, keep the liquid temperature below 149 °F (65 °C) to eliminate the risk of lime precipitation. To avoid condensation in the control box and stator, the liquid temperature must always be higher than the ambient temperature.

\*\* Curves apply to a density of 983.2 kg/m<sup>3</sup> and a liquid temperature of 140 °F (60 °C). All curves show average values and should not be used as guarantee curves. If a specific minimum performance is required, individual measurements must be made. Curves apply to a kinematic viscosity of 0.474 cSt.

## Technical data, ALPHA 15-55 HWR-D

### ALPHA 15-55 HWR-D models

Flow (Q)	Max. 26 gpm (5.9 m <sup>3</sup> /h)
Head (H)	Max. 42 ft (12.8 m)
Supply voltage	1 x 115 V, +10 % / -10 %, 60 Hz. Requires no external motor protection.
Power usage (approximate):	Min.: 2 W Max.: 45 W
Enclosure class	Indoor use only, IP42. CSA enclosure type 2.
Liquid temperature	36 to 230 °F (2 to 110 °C)*
Relative humidity	Max. 95 %
Ambient temp.	34 to 104 °F (1 to 40 °C)*
Insulation class	F
Max. outlet pressure	150 psi (10.34 bars) (1.0 MPa)
Sound pressure level	43 dB (A)
Approvals	Intertek US Listed, FCC.  Complies to limits for class B digital device, pursuant to Part 15 of the FCC Rules.
Flange-to-flange length	
Pump housing	Cast iron
Connection type	Flanged connection

## Materials

### ALPHA2 and ALPHA1

Description	Material
Controller complete	Composite, PC
Rotor can	Stainless steel
Radial bearing	Ceramics
Shaft	Ceramics
Rotor cladding	Stainless steel
Thrust bearing	Carbon
Thrust bearing retainer	EPDM (ethylene propylene rubber)
Bearing plate	Stainless steel
Impeller	PES composite (30 % glass-filled)
Pump housing	Cast iron or stainless steel
Gaskets	EPDM (ethylene propylene rubber)

## Approvals

### Approvals for ALPHA1 15-55 and ALPHA2 15-55 models



TM073285



TM073284

#### FCC sections

##### Section 15.19 (a) 3

This device complies with Part 15 of the FCC Rules. The operation is subject to the following two conditions: (1) this device may not cause harmful interference, and (2) this device must accept any interference received, including interference that may cause undesired operation.

##### Section 15.21

Any changes or modifications to this equipment not expressly approved by the party responsible for compliance could void the user's authority to operate this equipment.

##### Section 15.105 (b)

This equipment has been tested and found to comply with the limits for a class B digital device, pursuant to Part 15 of the FCC Rules.

These limits are designed to provide reasonable protection against harmful interference in a residential installation. This equipment generates, uses and can radiate radio frequency energy and, if not installed and used in accordance with the instructions, may cause harmful interference to radio communications. However, there is no guarantee that interference will not occur in a particular installation. If this equipment does cause harmful interference to radio or television reception, which can be determined by turning the equipment off and on, the user is encouraged to try to correct the interference by one or more of the following measures:

- Reorient or relocate the receiving antenna.
- Increase the separation between the equipment and the receiver.
- Connect the equipment to an outlet on a circuit different from that to which the receiver is connected.
- Consult the dealer or an experienced radio/ TV technician for help.

#### Canadian EMC Standard: ICES-003

This class B digital apparatus complies with Canadian ICES-003.

### Approvals for ALPHA1 26-99 and ALPHA2 26-99 models



TM070539

Grundfos cULus listed pumps are tested and evaluated with water only.

ALPHA1 26-99/ALPHA2 26-99 pumps for the North American market are UL approved (E96215 vol. 1 and MH26400). Approval codes:

Model	Code	Voltage	Power	Control mode
ALPHA1 26-99	GFJOD	115 V	120 W	VDC
ALPHA2 26-99	GFJOF	115 V	120 W	AUTO

### Approvals, ALPHA 15-55 HWR-D models and accessories



TM073285



TM073284

#### FCC sections

##### Section 15.19 (a) 3

This device complies with Part 15 of the FCC Rules. The operation is subject to the following two conditions: (1) this device may not cause harmful interference, and (2) this device must accept any interference received, including interference that may cause undesired operation.

##### Section 15.21

Any changes or modifications to this equipment not expressly approved by the party responsible for compliance could void the user's authority to operate this equipment.

##### Section 15.105 (b)

This equipment has been tested and found to comply with the limits for a class B digital device, pursuant to Part 15 of the FCC Rules.

These limits are designed to provide reasonable protection against harmful interference in a residential installation. This equipment generates, uses and can radiate radio frequency energy and, if not installed and used in accordance with the instructions, may cause harmful interference to radio communications. However, there is no guarantee that interference will not occur in a particular installation. If this equipment does cause harmful interference to radio or television reception, which can be determined by turning the equipment off and on, the user is encouraged to try to correct the interference by one or more of the following measures:

- Reorient or relocate the receiving antenna.
- Increase the separation between the equipment and the receiver.
- Connect the equipment to an outlet on a circuit different from that to which the receiver is connected.
- Consult the dealer or an experienced radio/ TV technician for help.

This equipment complies with FCC/IC radiation exposure limits set forth for an uncontrolled environment and meets the FCC radio frequency (RF) Exposure Guidelines and RSS-102 of the IC radio frequency (RF) Exposure rules. This equipment should be installed and operated keeping the radiator at least 8 in (20 cm) or more away from person's body.

Cet équipement est conforme aux limites d'exposition aux rayonnements définies par la norme FCC / IC pour un environnement non contrôlé et est conforme aux directives d'exposition de la FCC en matière de radiofréquences et la norme RSS-102, des règles d'exposition aux radiofréquences (RF) de l'IC. Cet équipement doit être installé et utilisé en maintenant le radiateur à au moins 8 in (20 cm) du corps de la personne.

#### **Canadian ISED information**

These devices (ALPHA 15-55 HWR-D, Pushbutton HWR-D, Temperature sensor HWR-D and Repeater HWR-D) contain license-exempt transmitter(s)/receiver(s) that comply with Innovation, Science and Economic Development Canada's license-exempt RSS(s). Operation is subject to the following two conditions: 1. This device may not cause interference. 2. This device must accept any interference, including interference that may cause undesired operation of the device. Innovation, Science and Economic Development Canada ICES-003 Compliance Label: CAN ICES-3(B)/NMB-3(B).

L'émetteur/récepteur exempt de licence contenu dans le présent appareil est conforme aux CNR d'Innovation, Sciences et Développement économique Canada applicables aux appareils radio exempts de licence.

L'exploitation est autorisée aux deux conditions suivantes :

1. L'appareil ne doit pas produire de brouillage; 2. L'appareil doit accepter tout brouillage radioélectrique subi, même si le brouillage est susceptible d'en compromettre le fonctionnement. Étiquette de conformité à la NMB-003 d'Innovation, Sciences et Développement économique Canada : CAN ICES-3(B)/-3(B).

These devices (ALPHA 15-55 HWR-D, Push-button HWR-D, Temperature sensor HWR-D and Repeater HWR-D) comply with Industry Canada RSS-247 and license-exempt RSS standard(s). Operation is subject to the following two conditions: (1) this device may not cause interference, and (2) this device must accept any interference, including interference that may cause undesired operation of the device.

Ce dispositif est conforme à la norme CNR-247 d'Industrie Canada applicable aux appareils radio exempts de licence. Son fonctionnement est sujet aux deux conditions suivantes: (1) le dispositif ne doit pas produire de brouillage préjudiciable, et (2) ce dispositif doit accepter tout brouillage reçu, y compris un brouillage susceptible de provoquer un fonctionnement indésirable.

## 7. Dimensions and weights

### ALPHA2 15-55

ALPHA2 15-55 terminal box

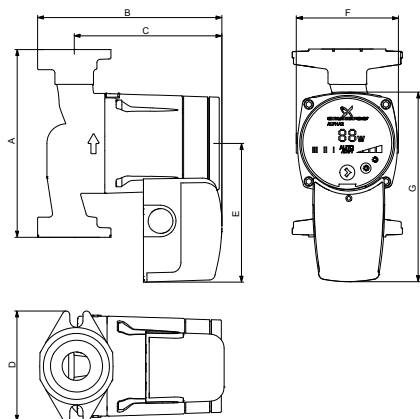

TM068168

ALPHA2 15-55 line cord

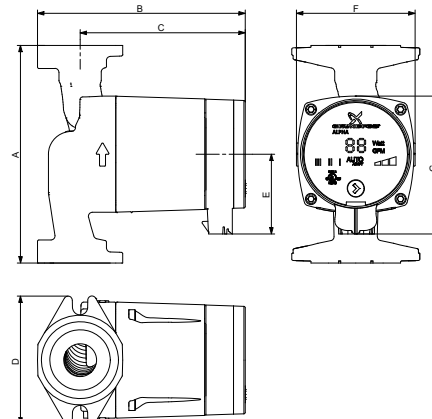

TM046012

ALPHA2 15-55 FR terminal box

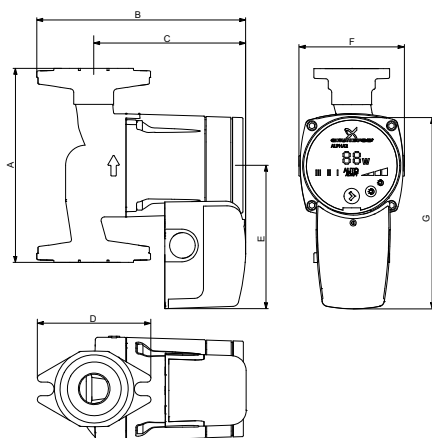

TM068169

ALPHA2 15-55 FR line cord

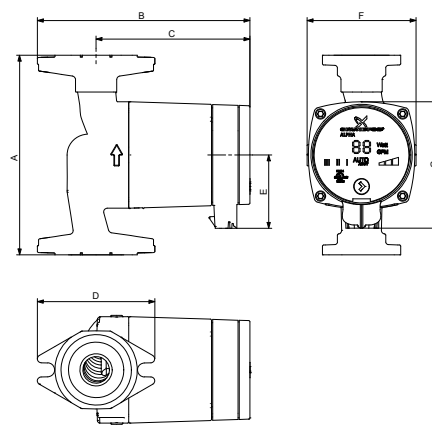

TM046013

ALPHA 2 model	Product number	Dimensions [in (mm)]							Flange	Ship. wt. [lb (kg)]
		A	B	C	D	E	F	G		
15-55 F	99163903	6.50 (165)	6.38 (162)	5.12 (130)	3.82 (97)	4.80 (122)	3.56 (90)	6.42 (163)	GF 15/26 with (2) 1/2" dia. bolt holes	7.2 (15.8)
15-55 FR	99163932	6.50 (165)	7.01 (178)	5.12 (130)	3.82 (97)	4.80 (122)	3.56 (90)	6.42 (163)		7.1 (15.6)
15-55 SF	99163937	6.50 (165)	6.38 (162)	5.12 (130)	3.82 (97)	4.80 (122)	3.56 (90)	6.42 (163)		6.1 (13.4)
15-55 F/LC	99163906	6.50 (165)	6.50 (165)	4.94 (125)	4.00 (102)	2.50 (64)	3.44 (87)	4.13 (105)	GF 15/26 with (2) 1/2" dia. bolt holes	7.5 (16.5)
15-55 FR/LC	99163934	6.50 (165)	7.00 (178)	4.94 (125)	4.00 (102)	2.50 (64)	3.44 (87)	4.13 (105)		7.3 (16.1)
15-55 SF/LC	99163972	6.50 (165)	6.50 (165)	4.94 (125)	4.00 (102)	2.50 (64)	3.44 (87)	4.13 (105)		6.3 (13.8)

**Note:** Dimensions are in inches unless otherwise stated. LC models have a 6 ft (1.8 m), 3-prong line cord.



ALPHA1 15-55

ALPHA1 15-55 terminal box

ALPHA1 15-55 line cord

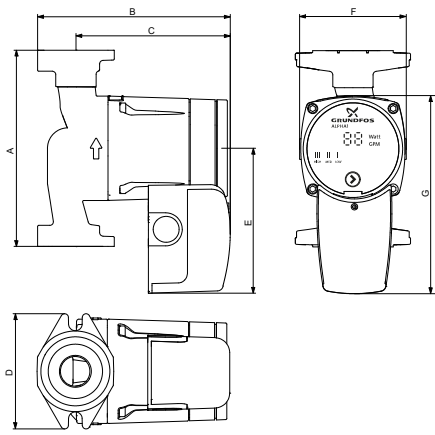

TM068963

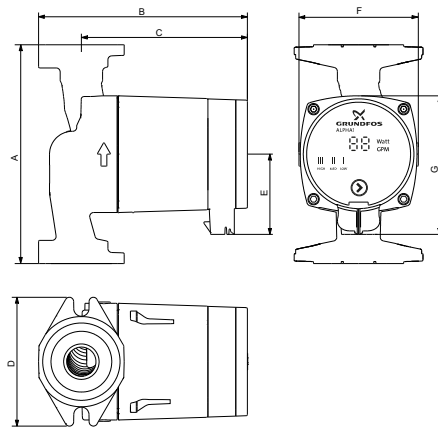

TM068961

ALPHA1 15-55 FR terminal box

ALPHA1 15-55 FR line cord

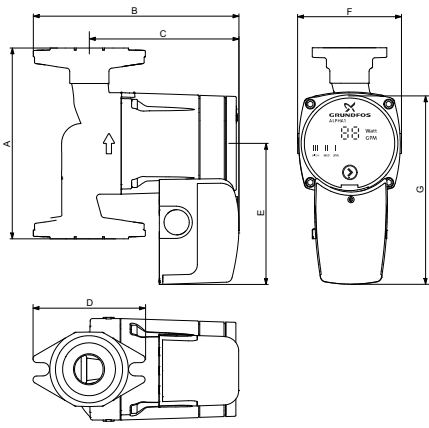

TM068964

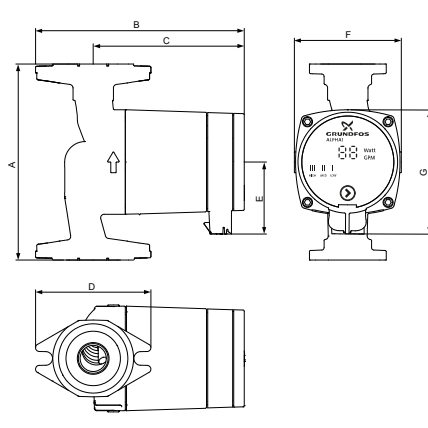

TM068962

ALPHA 1 model	Product number	Dimensions [in (mm)]							Flange	Ship. wt. [lb (kg)]
		A	B	C	D	E	F	G		
15-55 F	99287256	6.50 (165)	6.38 (162)	5.12 (130)	3.82 (97)	4.80 (122)	3.56 (90)	6.42 (163)	GF 15/26 with (2) 1/2" dia. bolt holes	7.2 (15.8)
15-55 FR	99287259	6.50 (165)	7.01 (178)	5.12 (130)	3.82 (97)	4.80 (122)	3.56 (90)	6.42 (163)		7.1 (15.6)
15-55 SF	99287262	6.50 (165)	6.38 (162)	5.12 (130)	3.82 (97)	4.80 (122)	3.56 (90)	6.42 (163)		6.1 (13.4)
15-55 F/LC	99285998	6.50 (165)	6.50 (165)	4.94 (125)	4.00 (102)	2.50 (64)	3.44 (87)	4.13 (105)	GF 15/26 with (2) 1/2" dia. bolt holes	7.5 (16.5)
15-55 FR/LC	99287244	6.50 (165)	7.00 (178)	4.94 (125)	4.00 (102)	2.50 (64)	3.44 (87)	4.13 (105)		7.3 (16.1)
15-55 SF/LC	99287250	6.50 (165)	6.50 (165)	4.94 (125)	4.00 (102)	2.50 (64)	3.44 (87)	4.13 (105)		6.3 (13.8)

**Note:** Dimensions are in inches unless otherwise stated. LC models have a 6 ft (1.8 m), 3-prong line cord.

## ALPHA2 26-99

ALPHA2 26-99

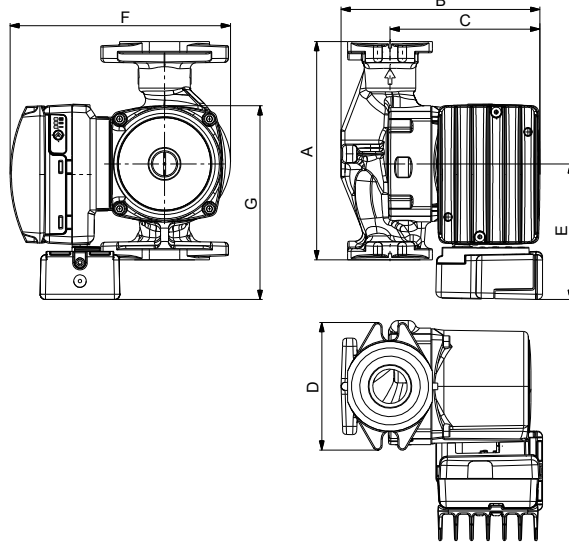

TM074562

ALPHA1 26-99

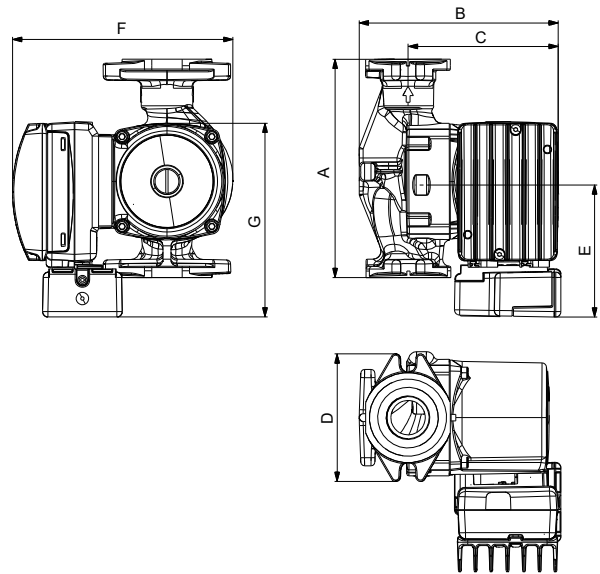

TM074563

Model	Product number	Dimensions [in (mm)]							Flange	Ship. wt. [lb (kg)]
		A	B	C	D	E	F	G		
ALPHA2 26-99	99490916	6.50 (165)	5.91 (150)	4.45 (113)	3.78 (96)	4.06 (103)	6.58 (167)	5.79 (147)	GF 15/26 with (2) 1/2" dia. bolt holes	5.95 (2.7)
ALPHA1 26-99	99490914									

**Note:** Dimensions are in inches unless otherwise stated. LC models have a 6 ft (1.8 m), 3-prong line cord.

## ALPHA 15-55 HWR-D

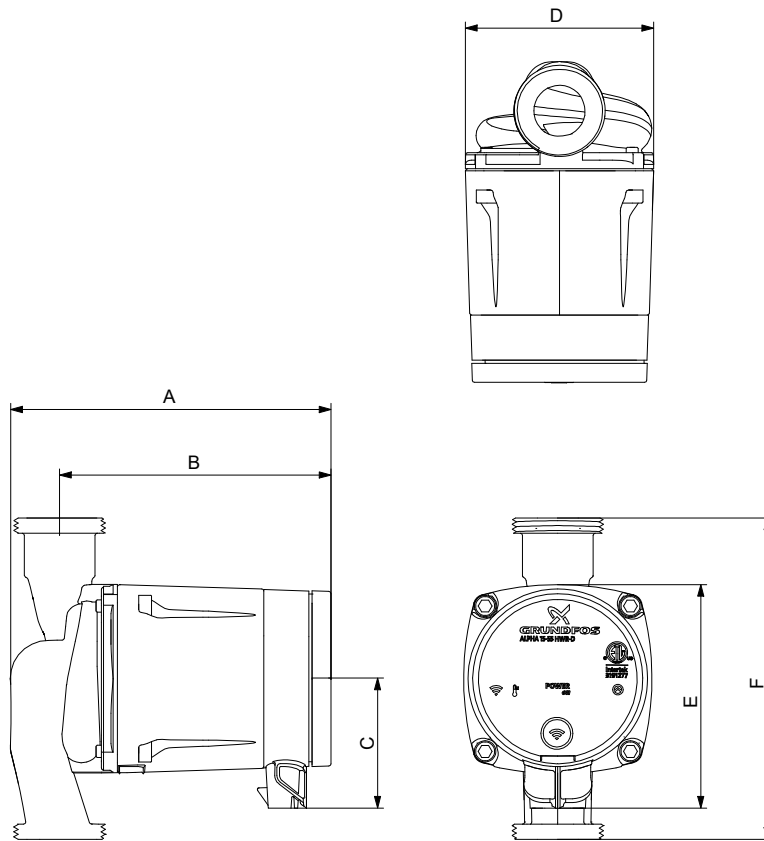

TM072657

ALPHA model	Product number	Dimensions [in (mm)]						Connection	Ship. wt. [lb (kg)]
		A	B	C	D	E	F		
15-55 HWR-D	99472723	5.89	4.99	2.39	3.46 (88)	4.11	5.91	1 1/4" NSPM	5.75 (2.61)
	99472724	(149.6)	(126.7)	(60.8)		(104.5)	(150)		

**Note:** Dimensions are in inches unless otherwise stated. LC models have a 6 ft (1.8 m), 3-prong line cord.

## 8. Accessories

### Accessories for ALPHA

Accessories, ALPHA 2



**Fig.** ALPHA2 with insulating shell

#### Insulating shells

Insulating shells limit the heat loss from the pump housing and pipes.

Insulating shells are supplied with ALPHA2 cast iron and stainless steel flanged versions. Insulating shells are available as an accessory for ALPHA2 15-55 and ALPHA1 15-55 models.

The fitting of insulating shells will increase the pump dimensions.

Description	Product number
Insulating shell for ALPHA2 circulator pump	99348254

Accessories, ALPHA HWR-D models



**Fig.** Accessories, ALPHA 15-55 HWR-D

Pos.	Product number	Description
1	99410350	Temperature sensor HWR-D - one temperature sensor is either included with delivery or may be purchased as an accessory.
2	99410378	Push-button HWR-D - two push-buttons are included with the circulator. Additional push-buttons may be purchased as accessories.
3	99410217	Repeater HWR-D - a repeater is not included but may be purchased as an accessory to increase the range of communication between the push-button and the pump.

**U.S.A.**

GRUNDFOS Pumps Corporation  
9300 Loiret Boulevard  
Lenexa, Kansas 66219 USA  
Tel.: +1 913 227 3400  
Fax: +1 913 227 3500

GRUNDFOS Water Utility Inc.  
3905 Enterprise Court  
P.O. Box 6620  
Aurora, IL 60598-0620  
Phone: +1-630-236-5500  
Fax: +1-630-236-5511

GRUNDFOS CBS Inc.  
902 Koomey Road  
Brookshire, TX 77423 USA  
Phone: 281-994-2700  
Toll Free: 1-800-955-5847  
Fax: 1-800-945-4777

Peerless Pump  
2005 Dr. Martin Luther King Jr  
US-46202 Indianapolis, Indiana U.S.A.  
Phone:317-925-9661

**Canada**

GRUNDFOS Canada Inc.  
2941 Brighton Road  
Oakville, Ontario  
L6H 6C9  
Tel.: +1-905 829 9533  
Fax: +1-905 829 9512

**Mexico**

Bombas GRUNDFOS de México  
S.A. de C.V.  
Boulevard TLC No. 15  
Parque Industrial Stiva Aeropuerto  
Apodaca, N.L. 66600  
Tel.: +52-81-8144 4000  
Fax: +52-81-8144 4010

**Revision Info**

Last revised on 13-10-2016

<b>99507863</b> 0619
ECM: 1250373

