

TPE2 (D), TPE3 (D)

Single-stage in-line pumps with integrated variable frequency drive

Installation and operating instructions

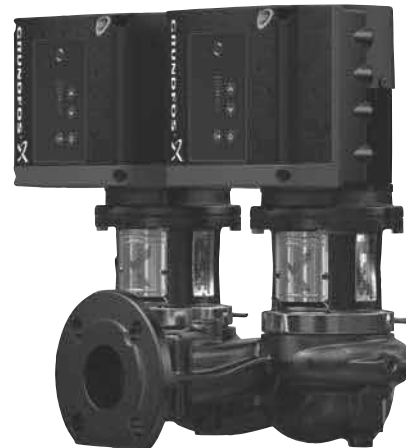
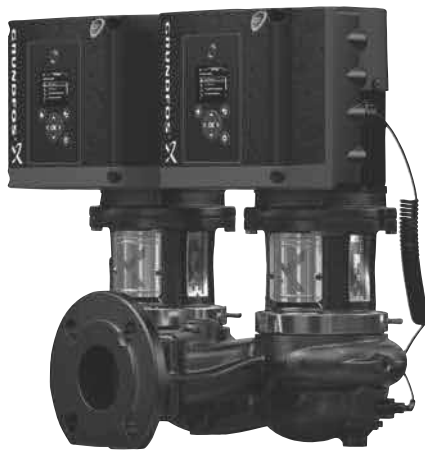

English (US) Installation and operating instructions

Original installation and operating instructions.

CONTENTS

	Page		Page
1. Symbols used in this document	3	15.4 Control mode	26
2. Limited warranty	3	15.5 FLOWLIMIT	31
3. Abbreviations and definitions	4	15.6 Automatic Night Setback	31
4. General information	4	15.7 Analog inputs	31
4.1 Radio communication	4	15.8 Pt100/1000 inputs	31
4.2 Battery	4	15.9 Digital inputs	32
5. Delivery and handling	4	15.10 Digital inputs/outputs	32
5.1 Delivery	4	15.11 Relay outputs	33
5.2 Handling	4	15.12 Analog output	33
6. Applications	5	15.13 Controller settings	33
6.1 Pumped liquids	5	15.14 Operating range	34
7. Operating conditions	5	15.15 Setpoint influence	35
7.1 Maximum number of starts and stops	5	15.16 Monitoring functions	38
7.2 Alternating operation of twin-head pumps	5	15.17 Special functions	38
7.3 Liquid temperature	5	15.18 Communication	38
7.4 Ambient temperature	5	15.19 General settings	39
7.5 Operating pressure/test pressure	5	16. Assist	39
7.6 Inlet pressure	6	16.1 Multi-pump setup	39
7.7 Electrical data	6	17. Selection of control mode	40
7.8 Sound pressure level	6	18. Changing the position of the control panel	42
7.9 Environment	6	19. Bus signal	43
7.10 Installation altitude	6	20. Priority of settings	43
7.11 Air humidity	6	21. Grundfos Eye	44
7.12 Motor cooling	6	22. Signal relays	45
8. Mechanical installation	7	23. Maintenance and service	46
8.1 Pipework	7	23.1 Maintenance	46
8.2 Terminal box positions	8	23.2 Service	46
8.3 Fitting of pump head	8	24. Fault finding	47
8.4 Base plate	9	25. Megging	48
8.5 Insulation	9	26. Technical data, single-phase motors	48
8.6 Frost protection	9	26.1 Supply voltage	48
8.7 Ensuring motor cooling	9	26.2 Leakage current	48
8.8 Outdoor installation	9	27. Technical data, three-phase motors	48
9. Electrical installation	10	27.1 Supply voltage	48
9.1 Protection against electric shock, indirect contact	10	27.2 Leakage current	48
9.2 Power supply	10	28. Inputs/outputs	48
9.3 Additional protection	11	29. Other technical data	49
9.4 Connection terminals	12	29.1 Torques	49
9.5 Signal cables	16	29.2 Sound pressure level	49
9.6 Bus connection cable	16	30. Disposal	49
10. Startup	16		
10.1 Flushing the pipe system	16		
10.2 Priming	16		
10.3 Starting	17		
10.4 Shaft seal run-in	17		
11. User interfaces	17		
12. Standard control panel	18		
12.1 Setpoint setting	18		
13. Advanced control panel	20		
13.1 Menu structure	20		
13.2 Menu overview for advanced control panel	21		
14. Grundfos GO Remote	23		
14.1 Communication	23		
14.2 Menu overview for Grundfos GO Remote	24		
15. Description of selected functions	26		
15.1 Setpoint	26		
15.2 Operating mode	26		
15.3 Set manual speed	26		

**Warning**

Prior to installation, read these installation and operating instructions. Installation and operation must comply with local regulations and accepted codes of good practice.

1. Symbols used in this document**Warning**

If these safety instructions are not observed, it may result in personal injury.

**Warning**

If these instructions are not observed, it may lead to electric shock with consequent risk of serious personal injury or death.

**Warning**

The surface of the product may be so hot that it may cause burns or personal injury.

**Warning**

Risk of dropping objects which may cause personal injury.

**Warning**

Escaping vapor involves the risk of personal injury.

**Caution**

If these safety instructions are not observed, it may result in malfunction or damage to the equipment.

**Note**

Notes or instructions that make the job easier and ensure safe operation.

2. Limited warranty

Products manufactured by GRUNDFOS PUMPS CORPORATION (Grundfos) are warranted to the original user only to be free of defects in material and workmanship for a period of 24 months from date of installation, but not more than 30 months from date of manufacture. Grundfos' liability under this warranty shall be limited to repairing or replacing at Grundfos' option, without charge, F.O.B. Grundfos' factory or authorized service station, any product of Grundfos' manufacture. Grundfos will not be liable for any costs of removal, installation, transportation, or any other charges which may arise in connection with a warranty claim. Products which are sold but not manufactured by Grundfos are subject to the warranty provided by the manufacturer of said products and not by Grundfos' warranty. Grundfos will not be liable for damage or wear to products caused by abnormal operating conditions, accident, abuse, misuse, unauthorized alteration or repair, or if the product was not installed in accordance with Grundfos' printed installation and operating instructions.

To obtain service under this warranty, the defective product must be returned to the distributor or dealer of Grundfos' products from which it was purchased together with proof of purchase and installation date, failure date, and supporting installation data. Unless otherwise provided, the distributor or dealer will contact Grundfos or an authorized service station for instructions. Any defective product to be returned to Grundfos or a service station must be sent freight prepaid; documentation supporting the warranty claim and/or a Return Material Authorization must be included if so instructed.

GRUNDFOS WILL NOT BE LIABLE FOR ANY INCIDENTAL OR CONSEQUENTIAL DAMAGES, LOSSES, OR EXPENSES ARISING FROM INSTALLATION, USE, OR ANY OTHER CAUSES. THERE ARE NO EXPRESS OR IMPLIED WARRANTIES, INCLUDING MERCHANTABILITY OR FITNESS FOR A PARTICULAR PURPOSE, WHICH EXTEND BEYOND THOSE WARRANTIES DESCRIBED OR REFERRED TO ABOVE.

Some jurisdictions do not allow the exclusion or limitation of incidental or consequential damages and some jurisdictions do not allow limit actions on how long implied warranties may last. Therefore, the above limitations or exclusions may not apply to you. This warranty gives you specific legal rights and you may also have other rights which vary from jurisdiction to jurisdiction.

3. Abbreviations and definitions

AI	Analog input.
AL	Alarm, out of range at lower limit.
AO	Analog output.
AU	Alarm, out of range at upper limit.
Current sinking	The ability to draw current into the terminal and guide it towards GND in the internal circuitry.
Current sourcing	The ability to push current out of the terminal and into an external load which must return it to GND.
DI	Digital input.
DO	Digital output.
ELCB	Earth leakage circuit breaker.
FM	Functional module.
GDS	Grundfos Digital Sensor. Factory-fitted sensor in some Grundfos pumps.
GENiBus	Proprietary Grundfos fieldbus standard.
GFCI	Ground fault circuit interrupter. (USA and Canada).
GND	Ground.
Grundfos Eye	Status indicator light.
LIVE	Low voltage with the risk of electric shock if the terminals are touched.
OC	Open collector: Configurable open-collector output.
PE	Protective earth. Protective extra-low voltage.
PELV	A voltage that cannot exceed ELV under normal conditions and under single-fault conditions, except earth faults in other circuits.
SELV	Safety extra-low voltage. A voltage that cannot exceed ELV under normal conditions and under single-fault conditions, including earth faults in other circuits.
TPE2	Single-head TPE2 pump without factory-fitted differential-pressure and temperature sensor.
TPE2 D	Twin-head TPE2 D pump without factory-fitted differential-pressure and temperature sensor.
TPE3	Single-head TPE3 pump with factory-fitted differential-pressure and temperature sensor.
TPE3 D	Twin-head TPE3 D pump with factory-fitted differential-pressure and temperature sensor.

4. General information

These installation and operating instructions apply to the Grundfos TPE2 (D) and TPE3 (D) pumps.

The pumps are fitted with frequency-controlled permanent-magnet motors for single-phase or three-phase power supply connection.

4.1 Radio communication

This product incorporates a radio module for remote control which is a class 1 device and can be used anywhere in the EU member states without restrictions.

For use in USA and Canada, see page 50.

Note

Some variants of these products and all products sold in China and Korea have no possibility of radio communication according to local legislation.

This product can communicate with the Grundfos GO Remote and other products of the same type via the built-in radio module. In some cases, an external antenna may be required. Only Grundfos-approved external antennas may be connected to this product, and only by a Grundfos-approved installer.

4.2 Battery

Pumps fitted with the advanced functional module (FM 300) incorporate a Li-ion battery. The Li-ion battery complies with the Battery Directive (2006/66/EC). The battery does not contain mercury, lead and cadmium.

5. Delivery and handling

5.1 Delivery

The pump is delivered from the factory in a carton with a wooden bottom, which is specially designed for transport by fork-lift truck or a similar vehicle.

5.2 Handling



Warning

TPE2 D, TPE3 D: The centrally positioned thread of the pump housing must not be used for lifting purposes as the thread is placed below the center of gravity of the pump.

Lift the pump by means of nylon straps. See figs 1 and 2.

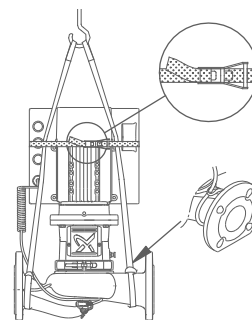

Fig. 1 TPE2, TPE3

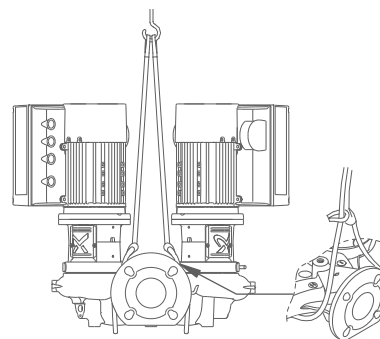

Fig. 2 TPE2 D, TPE3 D

TM05 7914 1613

TM05 7915 1613

6. Applications

The pumps are designed to circulate hot or cold water in:

- heating systems
- district heating plants
- air-conditioning systems
- cooling systems.

In addition, the pumps are used for liquid transfer and water supply in:

- washing systems
- domestic hot-water systems
- industrial systems in general.

To ensure optimum operation, the sizing range of the system must fall within the performance range of the pump.

6.1 Pumped liquids



Warning

If the pump is used for a liquid which is hazardous, it will be classified as contaminated. In such cases, the proper precautions must be taken to avoid injury to health when operating or working on the pump.

The pump is suitable for thin, clean, non aggressive and nonflammable liquids, not containing solid particles or fibers that may attack the pump mechanically or chemically.

Examples:

- central heating system water (the water should meet the requirements of accepted standards on water quality in heating systems)
- cooling liquids
- domestic hot water
- industrial liquids
- softened water.

The pumping of liquids with a density and/or kinematic viscosity higher than that of water will cause the following:

- a considerable pressure drop
- a drop in hydraulic performance
- a rise in power consumption.

In such cases, fit the pump with a bigger motor. If in doubt, contact Grundfos.

The EPDM O-rings fitted as standard are primarily suitable for water.

If the water being pumped contains minerals, synthetic oil, chemicals, or any liquids other than water, choose the O-rings accordingly.

7. Operating conditions

7.1 Maximum number of starts and stops

The number of starts and stops via the power supply must not exceed four times per hour.

When switched on via the power supply, the pump will start after approx. 5 seconds.

If you want a higher number of starts and stops, use the input for external start/stop when starting/stopping the pump.

When started via an external on/off switch, the pump will start immediately.

7.2 Alternating operation of twin-head pumps

On twin-head pumps, the duty and backup pumps must be alternated on a regular basis, i.e. once a week, to ensure an even distribution of the operating hours on both pumps. As default, the pumps alternate automatically. See section 16.1 *Multi-pump setup*.

If you use twin-head pumps for pumping domestic hot water, the duty and backup pumps must be alternated on a regular basis, i.e. once a day, to avoid blocking of the backup pump due to deposits (calcareous deposits, etc.). As default, the pumps alternate automatically. See section 16.1 *Multi-pump setup*.

7.3 Liquid temperature

-13 °F (-25 °C) up to 248 °F (+120 °C).

The maximum liquid temperature depends on the mechanical shaft seal type and the pump type.

Depending on the cast-iron version and the pump application, the maximum liquid temperature may be limited by local regulations and laws.

The maximum liquid temperature is stated on the pump nameplate.

If the pump is operating with liquids at high temperatures, the life of the shaft seal may be reduced. It may be necessary to replace the shaft seal more often.

Note

7.4 Ambient temperature

7.4.1 Ambient temperature during storage and transportation

-22 to 140 °F (-30 to +60 °C).

7.4.2 Ambient temperature during operation

-4 to 122 °F (-20 to +50 °C).

The motor can operate with the rated power output (P2) at 122 °F (50 °C), but continuous operation at higher temperatures will reduce the expected product life. If the motor is to operate at ambient temperatures between 122 and 140 °F (50 and 60 °C), select an oversized motor. Contact Grundfos for further information.

7.5 Operating pressure/test pressure

The pressure test has been made with water containing anti-corrosive additives at a temperature of +68 °F (+20 °C).

Operating pressure		Test pressure	
[bar]	[psi]	[bar]	[psi]
10	145	15	218

7.6 Inlet pressure

To ensure optimum and quiet pump operation, the inlet pressure (system pressure) must be adjusted correctly. See table on page 51.

For the calculation of specific inlet pressures, contact the local Grundfos company or see the data booklet for TP(D), TPE(D), TPE2 (D) and TPE3 (D) on www.grundfos.us.

7.7 Electrical data

See sections 26. *Technical data, single-phase motors* and 27. *Technical data, three-phase motors*.

For specific motor data, see the motor nameplate.

7.8 Sound pressure level

The sound pressure level of the pump is lower than 70 dB(A).

7.9 Environment

Non-aggressive and non-explosive atmosphere.

7.10 Installation altitude

Caution *The motor must not be installed more than 6562 ft (2000 m) above sea level.*

Installation altitude is the height above sea level of the installation site.

- Motors installed up to 3281 ft (1000 m) above sea level can be loaded 100 %.
- Motors installed more than 3281 ft (1000 m) above sea level must not be fully loaded due to the low density and consequent low cooling effect of the air. See fig. 3.

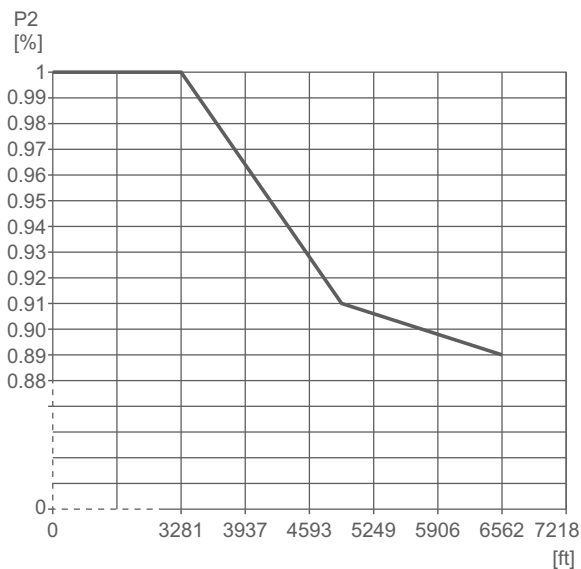

Fig. 3 Derating of motor output power (P2) in relation to altitude above sea level

TM05 6400-U.S. 1013

7.11 Air humidity

Maximum air humidity: 95 %.

If the air humidity is constantly high and above 85 %, one of the drain holes in the drive-end flange must be open. See section 5. *Delivery and handling*.

7.12 Motor cooling

To ensure cooling of motor and electronics, observe the following:

- Position the motor in such a way that adequate cooling is ensured. See section 8.7 *Ensuring motor cooling*.
- The temperature of the cooling air must not exceed 122 °F (50 °C).
- Keep cooling fins and fan blades clean.

8. Mechanical installation



Warning
When pumping hot or cold liquids, make sure that persons cannot accidentally come into contact with hot or cold surfaces.



Note
In order to maintain the UL mark, additional installation procedures must be followed. See page 50.

Install the pump in a dry well-ventilated, but frost-free position. When installing pumps with oval bolt holes in the pump flange, use washers as shown in fig. 4.

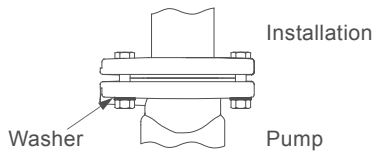

Fig. 4 Use of washers for oval bolt holes

Arrows on the pump housing show the direction of flow of liquid through the pump.

You can install the pump in horizontal or vertical pipes.



The motor must never fall below the horizontal plane.

For inspection and removal of motor or pump head, a clearance of 11.81" (300 mm) is required above the motor. See fig. 5.

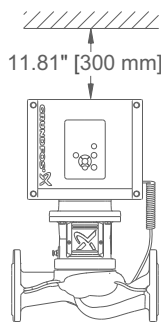

Fig. 5 Required clearance above the motor

Twin-head pumps installed in horizontal pipes must be fitted with an automatic air vent in the upper part of the pump housing. See fig. 6.

The automatic air vent is not supplied with the pump.

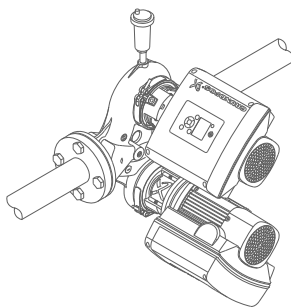

Fig. 6 Automatic air vent

If the liquid temperature falls below the ambient temperature, condensation may form in the motor during inactivity. In this case, make sure that one of the drain holes in the motor flange is open and points downwards. See fig. 7.

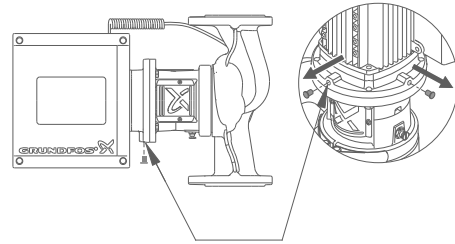

Fig. 7 Drain hole in motor flange

If twin-head pumps are used for pumping liquids with a temperature below 32 °F (0 °C), condensed water may freeze and cause the coupling to get stuck. You can solve the problem by installing heating elements. Whenever possible, install the pump with the motor shaft in horizontal position. See fig. 6.



Observe the conditions in section 11. User interfaces.

8.1 Pipework

Fit isolating valves on either side of the pump to avoid draining the system if the pump needs to be cleaned or repaired.

The pump is suitable for pipeline mounting, provided that the pipes are adequately supported on either side of the pump.

Single-head pumps are designed for pipeline mounting only.

Twin-head pumps are prepared for installation on a mounting bracket or base plate.

When installing the pipes, make sure that the pump housing is not stressed by the pipework.

The suction and discharge pipes must be of an adequate size, taking the pump inlet pressure into account.

To avoid sediment build-up, do not fit the pump at the lowest point of the system.

Install the pipes so that air locks are avoided, especially on the suction side of the pump. See fig. 8.

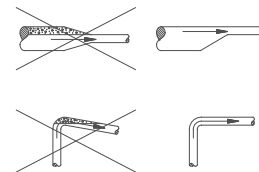

Fig. 8 Correct pipework on the suction side of the pump



The pump must not run against a closed discharge valve as this will cause an increase in temperature/formation of steam in the pump which may cause damage to the pump.

If there is any risk of the pump running against a closed discharge valve, ensure a minimum liquid flow through the pump by connecting a bypass/a drain to the discharge pipe. You can for instance connect the drain to a tank. A minimum flow rate equal to 10 % of the flow rate at maximum efficiency is needed at all times.

Flow rate and head at maximum efficiency are stated on the pump nameplate.

TM01 0683 1997

TM05 7916 1613

TM05 7983 1713

TM05 7917 1613

TM00 2263 0195

8.2 Terminal box positions



Warning

Before starting work on the pump, make sure that the power supply has been switched off for at least 5 minutes. Make sure that the power supply cannot be accidentally switched on.



Warning

If the pump head has been lifted partly or completely from the pump housing, pay special attention when fitting the pump head again. See 8.3 Fitting of pump head.



Warning

When loosening the clamp, do not drop the pump head. See fig. 9.



Warning

When loosening the clamp, there is a risk of escaping vapor. See fig. 9.

The terminal box can be turned to any position. Change the terminal box position as follows:

1. Loosen the clamp securing the pump head to the pump housing. See fig. 9.

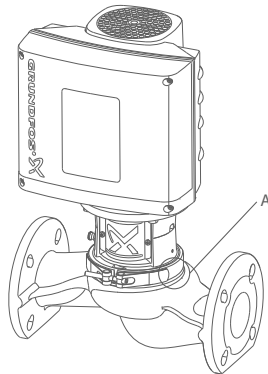

Fig. 9 Clamp (A)

2. Turn the pump head to the required position.
3. Check the following before you tighten the clamp:
 - The contact face of the pump housing and that of the pump head must be in full contact.
 - Position the clamp correctly in the flange recess of both the pump head and the pump housing. See fig. 12.

Tightening torque: 5.9 lbf-ft (± 0.75) (8 Nm (± 1)).

TM06 0721 0814

8.3 Fitting of pump head



Warning

Before starting work on the pump, make sure that the power supply has been switched off for at least 5 minutes. Make sure that the power supply cannot be accidentally switched on.



Warning

If the pump head has been lifted partly or completely from the pump housing, pay special attention when fitting the pump head again. See instructions below.



Warning

Do not drop the pump head. See fig. 9.



Warning

When loosening the clamp, there is a risk of escaping vapor. See fig. 9.

If for some reason the pump head has been lifted from the pump housing, follow the following procedure in order to mount the pump head correctly:

1. Visually check that the neck ring is centered in the pump housing. See fig. 10.

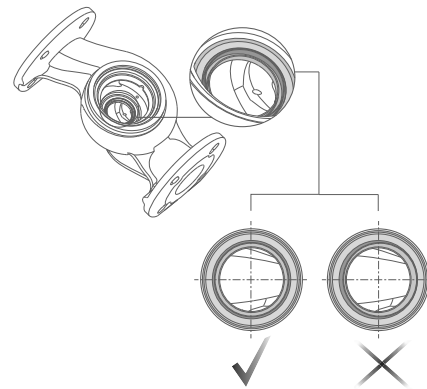

Fig. 10 Centering of neck ring

2. Gently lower the pump head with rotor shaft and impeller into the pump housing. See fig. 11.

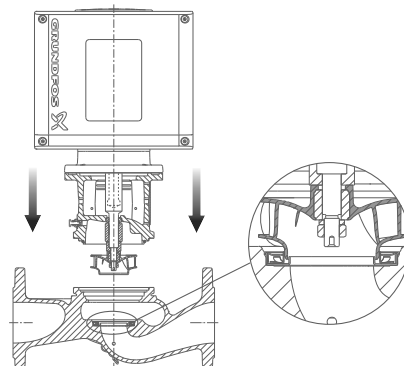

Fig. 11 Lowering of pump head

TM06 0722 0814

TM06 0723 0814

3. Check the following before you tighten the clamp:
 - The contact face of the pump housing and that of the pump head must be in full contact.
 - Position the clamp correctly in the flange recess of both the pump head and the pump housing. See fig. 12.
- Tightening torque: 5.9 lbf-ft (± 0.75) (8 Nm (± 1)).

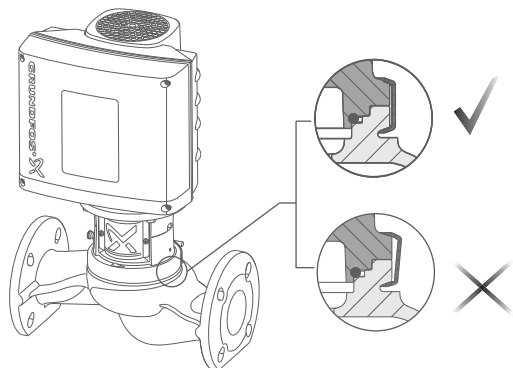

Fig. 12 Positioning of clamp ring

TM06 0724 0814

8.4 Base plate

Twin-head pumps have tapped holes in the bottom of the pump housing. The holes can be used for mounting a base plate.

8.5 Insulation

Caution *Do not insulate the motor stool as this will trap any vapor escaping from the shaft seal, thus causing corrosion. Covering the motor stool with insulation will also make inspection and service difficult.*

Follow the guidelines in fig. 13 when insulating the pump.

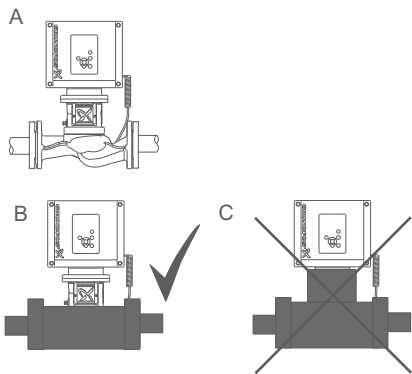

Fig. 13 Insulation of TPE2, TPE3 pumps

TM05 7918 1613

Pos.	Description
A	Without insulation
B	Correct insulation
C	Incorrect insulation

8.6 Frost protection

Pumps which are not being used during periods of frost must be drained to avoid damage.

8.7 Ensuring motor cooling

Note *In order to ensure sufficient cooling of the motor, the distance (D) between the end of the fan cover and a wall or other fixed objects must always be at least 2.0" (50 mm), irrespective of motor size. See fig. 14.*

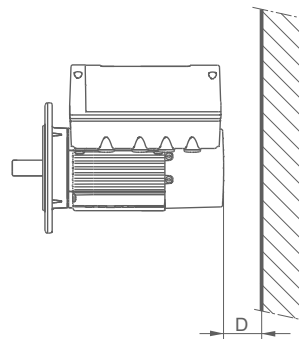

Fig. 14 Minimum distance (D) from the motor to a wall or other fixed objects

TM05 5236 3512

8.8 Outdoor installation

When installed outdoors, the motor must be provided with a suitable cover to avoid condensation on the electronic components. See fig. 15.

Note *When fitting a cover to the motor, observe the guideline in section 8.7 Ensuring motor cooling.*

The cover must be sufficiently large to ensure that the motor is not exposed to direct sunlight, rain or snow. Grundfos does not supply covers. We therefore recommend that you have a cover built for the specific application. In areas with high air humidity, we recommend that you enable the built-in standstill heating function.

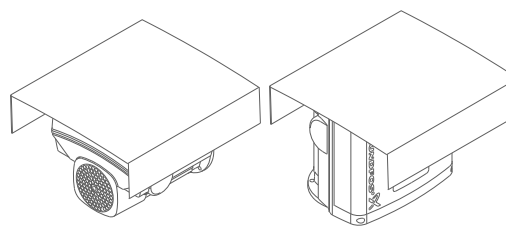

Fig. 15 Examples of covers (not supplied by Grundfos)

TM05 7919 1613

9. Electrical installation

Carry out the electrical connection according to local regulations. Check that the supply voltage and frequency correspond to the values stated on the nameplate.

Warning

Before making any connections in the terminal box, make sure that the power supply has been switched off for at least 5 minutes. Make sure that the power supply cannot be accidentally switched on.



The motor must be connected to an external all-pole power supply switch according to local regulations.

The motor must be grounded and protected against indirect contact in accordance with local regulations.

If the power supply cable is damaged, it must be replaced by the manufacturer, the manufacturer's service partner or a similarly qualified person.

The user or the installer is responsible for the installation of correct grounding and protection according to local regulations. All operations must be carried out by a qualified electrician.

Note

9.1 Protection against electric shock, indirect contact



Warning

The motor must be grounded and protected against indirect contact in accordance with local regulations.

9.1.1 Protection against power supply voltage transients

The motor is protected against power supply voltage transients in accordance with EN 61800-3.

9.1.2 Motor protection

The motor requires no external motor protection. The motor incorporates thermal protection against slow overloading and blocking.

9.2 Power supply

9.2.1 Single-phase supply voltage

- 1 x 200-240 V - 10 %/+ 10 %, 60 Hz, PE.

Check that the supply voltage and frequency correspond to the values stated on the nameplate.

The wires in the motor terminal box must be as short possible except for the separated ground conductor which must be so long that it is the last one to be disconnected in case the cable is inadvertently pulled out of the cable entry.

For maximum backup fuse, see section 26.1 *Supply voltage*.

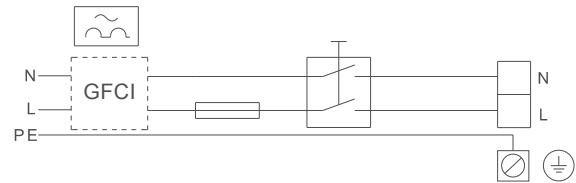

Fig. 16 Example of a power supply-connected motor with power supply switch, backup fuse and additional protection

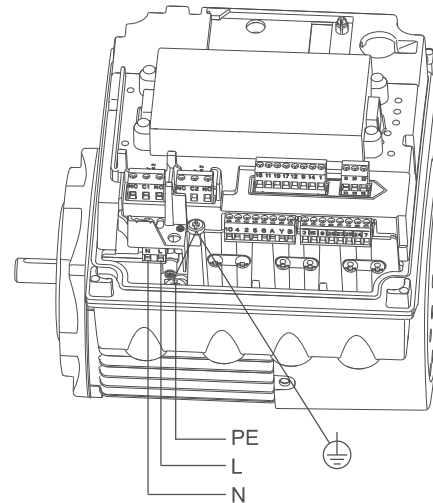

Fig. 17 Power supply connection, single-phase motors

TM05 4034 1912

TM05 3494 1512

9.2.2 Three-phase supply voltage

- 3 x 440-480 V - 10 %/+ 10 %, 60 Hz, PE.

Caution

In order to avoid loose connections, ensure that the terminal block for L1, L2 and L3 is pressed home in its socket when the supply cable has been connected.

Note

Corner grounding is not allowed for supply voltages above 3 x 480 V, 60 Hz.

Check that the supply voltage and frequency correspond to the values stated on the nameplate.

The wires in the motor terminal box must be as short as possible. Excepted from this is the separated earth conductor which must be so long that it is the last one to be disconnected in case the cable is inadvertently pulled out of the cable entry.

For maximum backup fuse, see section 27.1 Supply voltage.

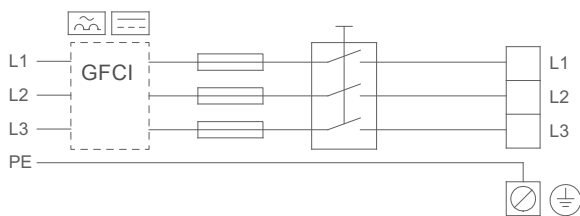

Fig. 18 Example of a power supply-connected motor with power supply switch, backup fuses and additional protection

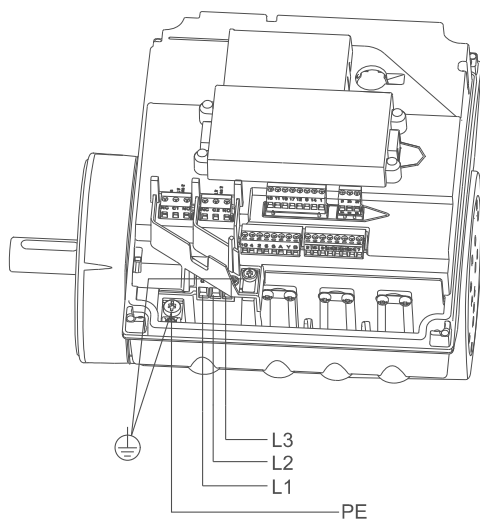

Fig. 19 Power supply connection, three-phase motors

TM05 3942 1812

TM05 3495 1512

9.3 Additional protection

9.3.1 Single-phase motors

If the motor is connected to an electric installation where an earth leakage circuit breaker (ELCB) or ground fault circuit interrupter (GFCI) is used as additional protection, this circuit breaker or interrupter must be marked with the following symbol:



Note

When an earth leakage circuit breaker or ground fault circuit interrupter is selected, the total leakage current of all the electrical equipment in the installation must be taken into account.

The leakage current of the motor can be found in section 26.2 Leakage current.

9.3.2 Three-phase motors

If the motor is connected to an electric installation where an earth leakage circuit breaker (ELCB) or ground fault circuit interrupter (GFCI) is used as additional protection, this circuit breaker or interrupter must be of the following type:

- It must be suitable for handling leakage currents and cutting-in with short pulse-shaped leakage.
- It must trip out when alternating fault currents and fault currents with DC content, i.e. pulsating DC and smooth DC fault currents, occur.

For these motors an earth leakage circuit breaker or ground fault circuit interrupter, type B, must be used.

This circuit breaker or interrupter must be marked with the following symbols:



Note

When you select an earth leakage circuit breaker or ground fault circuit interrupter, take into account the total leakage current of all the electrical equipment in the installation.

You find the leakage current of the motor in section 27.2 Leakage current.

Protection against phase unbalance

The motor must be connected to a power supply with a quality corresponding to IEC 60146-1-1, class C, to ensure correct motor operation at phase unbalance.

This also ensures long life of the components.

9.4 Connection terminals

The descriptions and terminal overviews in this section apply to both single-phase and three-phase motors.

For maximum tightening torques, see section *Torques*, page 49.

The number of terminals depends on the functional module (FM). You can identify the fitted module on the motor nameplate. See fig. 20.

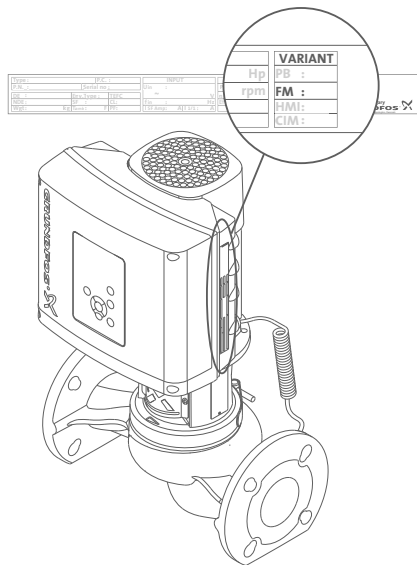

Fig. 20 Identification of functional module

9.4.1 Connection terminals, advanced functional module (FM 300)

The advanced functional module is only available as an option.

The advanced module has these connections:

- three analog inputs
- one analog output
- two dedicated digital inputs
- two configurable digital inputs or open-collector outputs
- Grundfos Digital Sensor input and output
- two Pt100/1000 inputs
- two LiqTec sensor inputs
- two signal relay outputs
- GENIbus connection.

See fig. 21.

Digital input 1 is factory-set to be start/stop input where open circuit will result in stop.

Note

A jumper has been factory-fitted between terminals 2 and 6. Remove the jumper if digital input 1 is to be used as external start/stop or any other external function.

Note

As a precaution, the wires to be connected to the connection groups below must be separated from each other by reinforced insulation in their entire lengths.

- **Inputs and outputs**

All inputs and outputs are internally separated from the power supply-conducting parts by reinforced insulation and galvanically separated from other circuits.

All control terminals are supplied by safety extra-low voltage (SELV), thus ensuring protection against electric shock.

- **Signal relay outputs**

– Signal relay 1:

LIVE:

Power supply voltages up to 250 VAC can be connected to this output.

SELV:

The output is galvanically separated from other circuits. Therefore, the supply voltage or safety extra-low voltage can be connected to the output as desired.

– Signal relay 2:

SELV:

The output is galvanically separated from other circuits. Therefore, the supply voltage or safety extra-low voltage can be connected to the output as desired.

- **Power supply** (terminals N, PE, L or L1, L2, L3, PE).

A galvanically safe separation must fulfil the requirements for reinforced insulation including creepage distances and clearances specified in EN 61800-5-1.

TM05 7928 1613

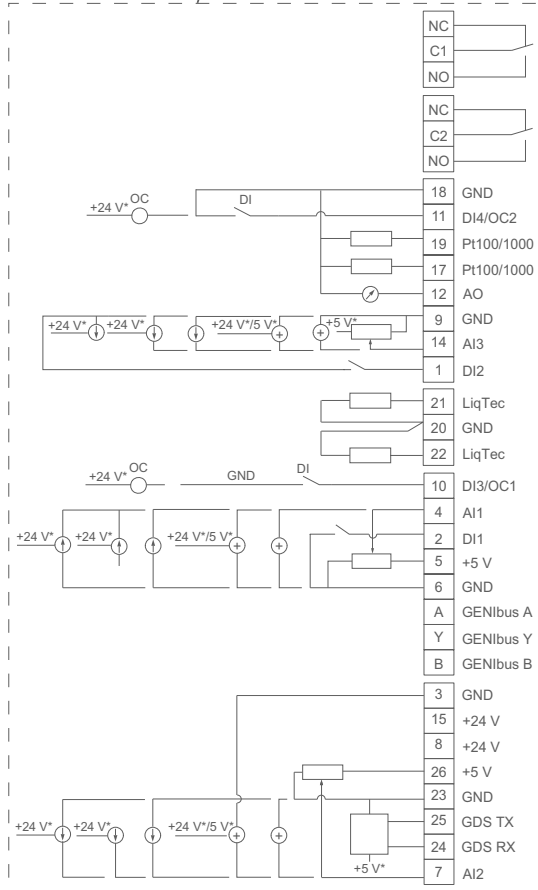
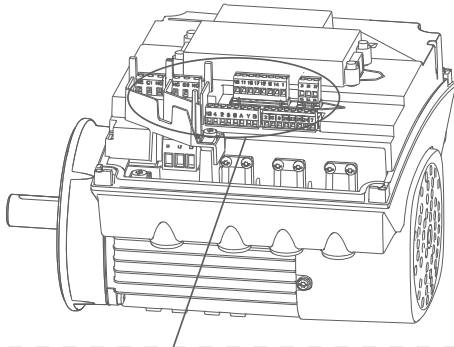

TM05 3509 3512

* If you use an external supply source, there must be a connection to GND.

Fig. 21 Connection terminals, FM 300 (option)

Terminal	Type	Function
NC	Normally closed contact	Signal relay 1 (LIVE or SELV)
C1	Common	
NO	Normally open contact	
NC	Normally closed contact	Signal relay 2 (SELV only)
C2	Common	
NO	Normally open contact	
18	GND	Ground
11	DI4/OC2	Digital input/output, configurable. Open collector: Max. 24 V resistive or inductive.
19	Pt100/1000 input 2	Pt100/1000 sensor input
17	Pt100/1000 input 1	Pt100/1000 sensor input
12	AO	Analog output: 0-20 mA / 4-20 mA 0-10 V
9	GND	Ground
14	AI3	Analog input: 0-20 mA / 4-20 mA 0-10 V
1	DI2	Digital input, configurable
21	LiqTec sensor input 1	LiqTec sensor input (white conductor)
20	GND	Ground (brown and black conductors)
22	LiqTec sensor input 2	LiqTec sensor input (blue conductor)
10	DI3/OC1	Digital input/output, configurable. Open collector: Max. 24 V resistive or inductive.
4	AI1	Analog input: 0-20 mA / 4-20 mA 0.5 - 3.5 V / 0-5 V / 0-10 V
2	DI1	Digital input, configurable
5	+5 V	Supply to potentiometer and sensor
6	GND	Ground
A	GENIbus, A	GENIbus, A (+)
Y	GENIbus, Y	GENIbus, GND
B	GENIbus, B	GENIbus, B (-)
3	GND	Ground
15	+24 V	Supply
8	+24 V	Supply
26	+5 V	Supply to potentiometer and sensor*
23	GND	Ground
25	GDS TX	Grundfos Digital Sensor output
24	GDS RX	Grundfos Digital Sensor input
7	AI2	Analog input: 0-20 mA / 4-20 mA 0.5 - 3.5 V / 0-5 V / 0-10 V

9.4.2 Connection terminals, standard functional module (FM 200)

The standard module has these connections:

- two analog inputs
- two digital inputs or one digital input and one open-collector output
- Grundfos Digital Sensor input and output
- two signal relay outputs
- GENIbus connection.

See fig. 22.

Digital input 1 is factory-set to be start/stop input where open circuit will result in stop.

Note

A jumper has been factory-fitted between terminals 2 and 6. Remove the jumper if digital input 1 is to be used as external start/stop or any other external function.

As a precaution, the wires to be connected to the connection groups below must be separated from each other by reinforced insulation in their entire lengths.

Note

- **Inputs and outputs**

All inputs and outputs are internally separated from the power supply-conducting parts by reinforced insulation and galvanically separated from other circuits.

All control terminals are supplied by safety extra-low voltage (SELV), thus ensuring protection against electric shock.

- **Signal relay outputs**

– Signal relay 1:

LIVE:

Power supply voltages up to 250 VAC can be connected to this output.

SELV:

The output is galvanically separated from other circuits.

Therefore, the supply voltage or safety extra-low voltage can be connected to the output as desired.

– Signal relay 2:

SELV:

The output is galvanically separated from other circuits.

Therefore, the supply voltage or safety extra-low voltage can be connected to the output as desired.

- **Power supply** (terminals N, PE, L or L1, L2, L3, PE).

A galvanically safe separation must fulfil the requirements for reinforced insulation including creepage distances and clearances specified in EN 61800-5-1.

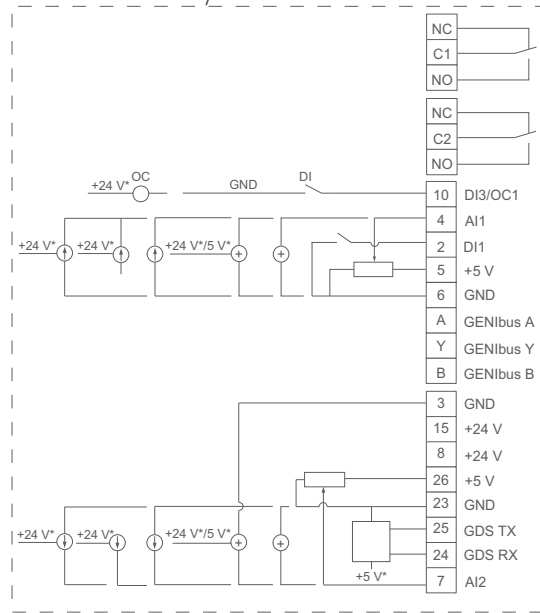
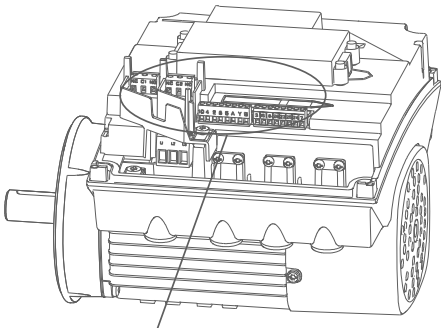

* If an external supply source is used, there must be a connection to GND.

Fig. 22 Connection terminals, FM 200

TM05 3510 3512

Terminal	Type	Function
NC	Normally closed contact	Signal relay 1 (LIVE or SELV)
C1	Common	
NO	Normally open contact	
NC	Normally closed contact	Signal relay 2 (SELV only)
C2	Common	
NO	Normally open contact	
10	DI3/OC1	Digital input/output, configurable. Open collector: Max. 24 V resistive or inductive.
4	AI1	Analog input: 0-20 mA / 4-20 mA 0.5 - 3.5 V / 0-5 V / 0-10 V
2	DI1	Digital input, configurable
5	+5 V	Supply to potentiometer and sensor
6	GND	Ground
A	GENIbus, A	GENIbus, A (+)
Y	GENIbus, Y	GENIbus, GND
B	GENIbus, B	GENIbus, B (-)
3	GND	Ground
15	+24 V	Supply
8	+24 V	Supply
26	+5 V	Supply to potentiometer and sensor*
23	GND	Ground
25	GDS TX	Grundfos Digital Sensor output
24	GDS RX	Grundfos Digital Sensor input
7	AI2	Analog input: 0-20 mA / 4-20 mA 0.5 - 3.5 V / 0-5 V / 0-10 V

9.5 Signal cables

- Use screened cables with a cross-sectional area of min. 20 AWG and max. 16 AWG (0.5 mm² and max. 1.5 mm²) for external on/off switch, digital inputs, setpoint and sensor signals.
- Connect the screens of the cables to frame at both ends with good connection. The screens must be as close as possible to the terminals. See fig. 23.

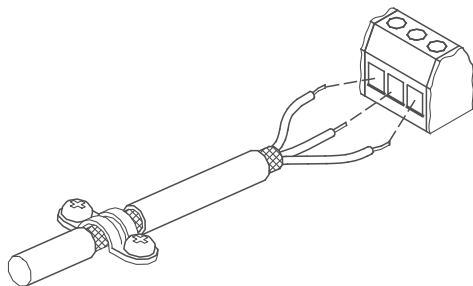

Fig. 23 Stripped cable with screen and wire connections

- Screws for frame connections must always be tightened whether a cable is fitted or not.
- The wires in the motor terminal box must be as short as possible.

9.6 Bus connection cable

9.6.1 New installations

For the bus connection, use a screened 3-core cable with a cross-sectional area of min. 20 AWG and max. 16 AWG (0.5 mm² and max. 1.5 mm²).

- If the motor is connected to a unit with a cable clamp which is identical to the one on the motor, connect the screen to this cable clamp.
- If the unit has no cable clamp as shown in fig. 24, leave the screen unconnected at this end.

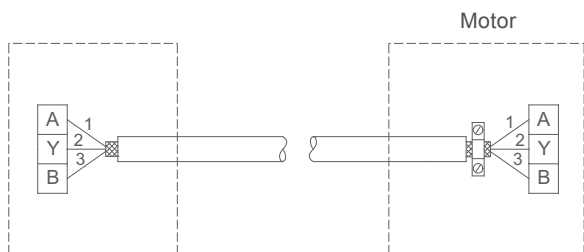

Fig. 24 Connection with screened 3-core cable

TM02 1325 4402

TM05 3973 1812

9.6.2 Replacing an existing motor

- If a screened 2-core cable is used in the existing installation, connect the cable as shown in fig. 25.

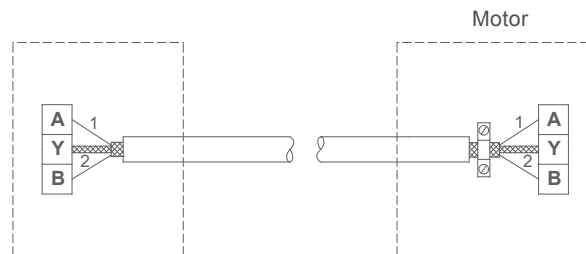

Fig. 25 Connection with screened 2-core cable

- If a screened 3-core cable is used in the existing installation, follow the instructions in section 9.6.1 *New installations*.

10. Startup

10.1 Flushing the pipe system

The pump is not designed to pump liquids containing solid particles such as pipe debris and welding slag. Before starting up the pump, clean the pipe system thoroughly, and flush and fill it with clean water.

Caution

The warranty does not cover any damage caused by flushing the pipe system by means of the pump.

10.2 Priming

Caution

Do not start the pump until it has been filled with liquid and vented. To ensure correct venting, the vent screw should point upwards.

Closed systems or open systems where the liquid level is above the pump inlet

1. Close the discharge isolating valve and loosen the air vent screw in the motor stool. See fig. 26.



Warning

Pay attention to the direction of the vent hole, and make sure that the escaping hot or cold liquid does not cause injury to persons or damage to the equipment.

2. Slowly open the isolating valve in the suction pipe until a steady stream of liquid runs out of the vent hole.
3. Tighten the air vent screw and completely open the isolating valve(s).

TM02 8842 0904

Open systems where the liquid level is below the pump inlet

The suction pipe and the pump must be filled with liquid and vented before you start the pump.

1. Close the discharge isolating valve and open the isolating valve in the suction pipe.
2. Loosen the air vent screw. See fig. 26.
3. Remove the plug from one of the pump flanges, depending on the pump location.
4. Pour liquid through the priming port until the suction pipe and the pump are filled with liquid.
5. Replace the plug and tighten securely.
6. Tighten the air vent screw.

The suction pipe can to some extent be filled with liquid and vented before it is connected to the pump. You can also install a priming device before the pump.

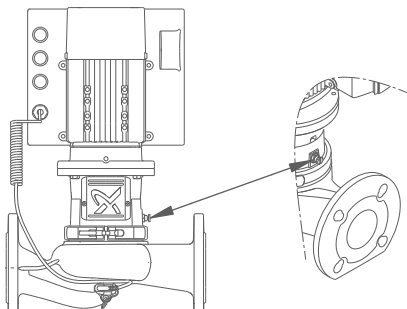

Fig. 26 Position of air vent screw

10.3 Starting

1. Before starting the pump, completely open the isolating valve on the suction side of the pump and leave the discharge isolating valve almost closed.
2. Start the pump. See section 11. *User interfaces*.
3. Vent the pump during starting by loosening the air vent screw in the motor stool until a steady stream of liquid runs out of the vent hole. See fig. 26.



Warning

Pay attention to the direction of the vent hole, and make sure that the escaping hot or cold liquid does not cause injury to persons or damage to the equipment.

4. When the pipe system has been filled with liquid, slowly open the discharge isolating valve until it is completely open.

10.4 Shaft seal run-in

The seal faces are lubricated by the pumped liquid, meaning that there may be a certain amount of leakage from the shaft seal.

When the pump is started up for the first time, or when a new shaft seal is installed, a certain run-in period is required before the leakage is reduced to an acceptable level. The time required for this depends on the operating conditions, i.e. every time the operating conditions change, a new run-in period will be started.

Under normal conditions, the leaking liquid will evaporate. As a result, no leakage will be detected.

However, liquids such as kerosene will not evaporate. The leakage may therefore be seen as a shaft seal failure.

11. User interfaces



Warning

The product may be so hot that only the buttons must be touched to avoid burns.

Pump settings can be made by means of the following user interfaces:

Control panels

- Standard control panel.
See section 12. *Standard control panel*.
- Advanced control panel.
See section 13. *Advanced control panel*.

Remote controls

- Grundfos GO Remote.
See section 14. *Grundfos GO Remote*.

If you switch-off the power supply to the pump, the settings will be stored.

Factory settings

TPE2 (D) pumps have been factory-set to constant-curve control mode. See section 12.1.2 *Pump in constant-curve control mode*.

The setpoint value corresponds to 100 %, of maximum pump performance. See data booklet or WebCAPS.

TPE3 (D) pumps have been factory-set to AUTO_{ADAPT} control mode. See section 15.4.1 *AUTOADAPT*.

TM05 7922 1613

12. Standard control panel

This control panel is fitted as standard on TPE2 (D) pumps.

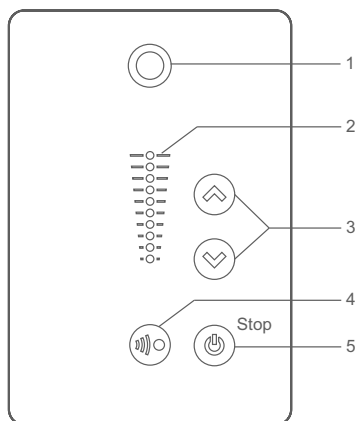

Fig. 27 Standard control panel

TM05 4848 3512

Pos.	Symbol	Description
1		Grundfos Eye Shows the operating status of the pump. See section 21. <i>Grundfos Eye</i> for further information.
2	-	Light fields for indication of setpoint.
3		Changes the setpoint.
4		Enables radio communication with the Grundfos GO Remote and other products of the same type.
5		Makes the pump ready for operation/starts and stops the pump. Start: If you press the button when the pump is stopped, the pump will only start if no other functions with higher priority have been enabled. See section 20. <i>Priority of settings</i> . Stop: If you press the button when the pump is running, the pump will always be stopped. When the pump is stopped via this button, the "Stop" text next to the button will illuminate.

12.1 Setpoint setting

Set the desired setpoint of the pump by pressing or . The light fields on the control panel will indicate the setpoint set.

12.1.1 Pump in differential-pressure control mode

The following example applies to a pump in an application where a pressure sensor gives a feedback to the pump. If you retrofit the sensor to the pump, you must set it up manually as the pump does not automatically register a connected sensor.

Figure 28 shows that the light fields 5 and 6 are activated, indicating a desired setpoint of 4.3 psi (3 m) with a sensor measuring range from 0 to 8.5 psi (0 to 6 m). The setting range is equal to the sensor measuring range.

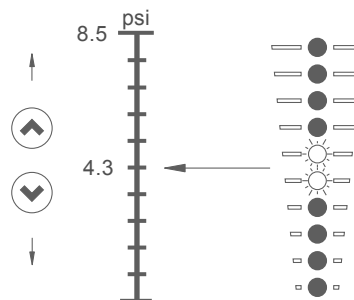

Fig. 28 Setpoint set to 4.3 psi (3 m), differential-pressure control

TM06 1116 1714

12.1.2 Pump in constant-curve control mode

In constant-curve control mode, the pump performance will lie between the maximum and minimum curve of the pump. See fig. 29.

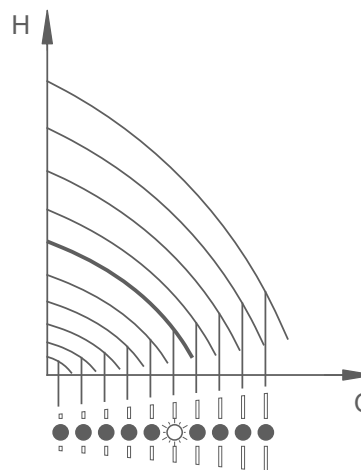





Fig. 29 Pump in constant-curve control mode

TM05 4895 2812

Setting to maximum curve:

- Press  continuously to change over to the maximum curve of the pump (top light field flashes). When the top light field is on, press  for 3 seconds until the light field starts flashing.
- To change back, press  continuously until the desired setpoint is indicated.

Example: Pump set to maximum curve.

Figure 30 shows that the top light field is flashing, indicating maximum curve.

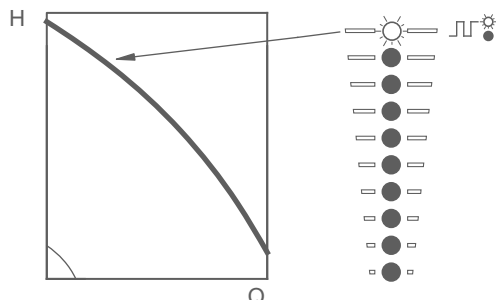





Fig. 30 Maximum curve duty

Setting to minimum curve:

- Press  continuously to change over to the minimum curve of the pump (bottom light field flashes). When the bottom light field is on, press  for 3 seconds until the light field starts flashing.
- To change back, press  continuously until the desired setpoint is indicated.

Example: Pump set to minimum curve.

Figure 31 shows that the bottom light field is flashing, indicating minimum curve.

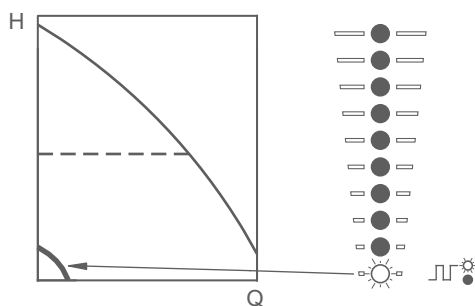









Fig. 31 Minimum curve duty

12.1.3 Start/stop of pump

Start the pump by pressing  or by continuously pressing  until the desired setpoint is indicated.

Stop the pump by pressing . When the pump is stopped, the "Stop" text next to the button will illuminate. You can also stop the pump by continuously pressing  until none of the light fields are on.





If you have stopped the pump by pressing , it can only be given free to operation by pressing  again.

If you have stopped the pump by pressing , it can only be restarted by pressing .

You can also stop the pump with the Grundfos GO Remote or via a digital input set to "External stop". See section 20. *Priority of settings*.

12.1.4 Resetting of fault indications

You can reset a fault indication in one of the following ways:

- Via the digital input if it has been set to "Alarm resetting".
- Briefly press  or  on the pump. This will not change the setting of the pump. You cannot reset a fault indication by pressing  or  if the buttons have been locked.
- Switch off the power supply until the indicator lights are off.
- Switch the external start/stop input off and then on again.
- With the Grundfos GO Remote.

TM05 4896 2812

TM05 4897 2812

13. Advanced control panel

This control panel is fitted as standard on TPE3 (D) pumps. TPE2 (D) pumps can be fitted with the advanced control panel as an option.

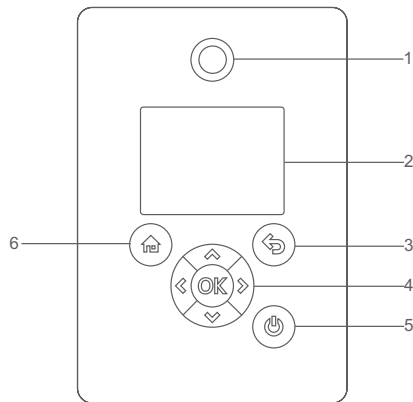

Fig. 32 Advanced control panel

TM05 4849 1013

Pos.	Symbol	Description
1		Grundfos Eye Shows the operating status of the pump. See section 21. <i>Grundfos Eye</i> for further information.
2	-	Graphical color display.
3		Goes one step back.
		Navigates between main menus, displays and digits. When the menu is changed, the display will always show the top display of the new menu.
4		Navigates between submenus.
		Saves changed values, resets alarms and expands the value field. Enables communication with the Grundfos GO Remote.
5		Makes the pump ready for operation/starts and stops the pump. Start: If you press the button when the pump is stopped, the pump will only start if no other functions with higher priority have been enabled. See section 20. <i>Priority of settings</i> . Stop: If you press the button when the pump is running, the pump will always be stopped. When you stop the pump via this button, the "Stop" text next to the button will illuminate.
6		Goes to the "Home" menu.

13.1 Menu structure

The pump incorporates a startup guide which is started at the first startup. After the startup guide, the four main menus will appear in the display.

1. Home

This menu shows up to four user-defined parameters with shortcuts or a graphical illustration of a Q/H performance curve.

2. Status

This menu shows the status of the pump and system as well as warnings and alarms.

Note

You cannot make any settings in this menu.

3. Settings

This menu gives access to all setting parameters. A detailed setting of the pump can be made in this menu.

See section 15. *Description of selected functions*.

4. Assist

This menu enables assisted pump setup, provides a short description of the control modes and offers fault advice.

See section 16. *Assist*.

13.2 Menu overview for advanced control panel

13.2.1 Main menus

Home	TPE3 (D)	TPE2 (D)
	•	•
Status	TPE3 (D)	TPE2 (D)
Operating status	•	•
Operating mode, from	•	•
Control mode	•	•
Pump performance	•	•
Actual controlled value	•	•
Max. curve and duty point	•	-
Resulting setpoint	•	•
Liquid temperature	•	-
Speed	•	•
Acc. flow and specific energy	•	•
Power and energy consumption	•	•
Measured values	•	•
Analog input 1	•	•
Analog input 2	•	•
Analog input 3	• ¹⁾	• ¹⁾
Pt100/1000 input 1	• ¹⁾	• ¹⁾
Pt100/1000 input 2	• ¹⁾	• ¹⁾
Analog output	• ¹⁾	• ¹⁾
Warning and alarm	•	•
Actual warning or alarm	•	•
Warning log	•	•
Alarm log	•	•
Heat energy meter	•	-
Heat power	•	-
Heat energy	•	-
Flow rate	•	-
Volume	•	-
Hours counter	•	-
Temperature 1	•	-
Temperature 2	•	-
Differential temp.	•	-
Operating log	•	•
Operating hours	•	•
Trend data	•	-
Fitted modules	•	•
Date and time	-	-
Product identification	•	•
Motor bearing monitoring	•	•
Multi-pump system	•	•
System operating status	•	•
System performance	•	•
System input power and energy	•	•
Pump 1, multi-pump sys.	•	•
Pump 2, multi-pump sys.	•	•
Pump 3, multi-pump sys.	•	•

¹⁾ Only available if an advanced functional module is fitted.

Settings	TPE3 (D)	TPE2 (D)	Section	Page
Setpoint	•	•	15.1 Setpoint	26
Operating mode	•	•	15.2 Operating mode	26
Set manual speed	•	•	15.3 Set manual speed	26
Control mode	•	•	15.4 Control mode	26
FLOW _{LIMIT}	•	•	15.5 FLOWLIMIT	31
Automatic Night Setback	•	-	15.6 Automatic Night Setback	31
Analog inputs	•	•	15.7 Analog inputs	31
Analog input 1, setup	•	•		
Analog input 2, setup	•	•		
Analog input 3, setup	• ¹⁾	• ¹⁾		
Built-in Grundfos sensor	•	-		
Pt100/1000 inputs	• ¹⁾	• ¹⁾	15.8 Pt100/1000 inputs	31
Pt100/1000, setup	• ¹⁾	• ¹⁾		
Digital inputs	•	•	15.9 Digital inputs	32
Digital input 1, setup	•	•		
Digital input 2, setup	• ¹⁾	• ¹⁾		
Digital inputs/outputs	•	•	15.10 Digital inputs/outputs	32
Digital input/output 3, setup	•	•		
Digital input/output 4, setup	• ¹⁾	• ¹⁾		
Relay outputs	•	•	15.11 Relay outputs	33
Relay output 1	•	•		
Relay output 2	•	•		
Analog output	• ¹⁾	• ¹⁾	15.12 Analog output	33
Output signal	• ¹⁾	• ¹⁾		
Function of analog output	• ¹⁾	• ¹⁾		
Controller settings	•	•	15.13 Controller settings	33
Operating range	•	•	15.14 Operating range	34
Setpoint influence	•	•	15.15 Setpoint influence	35
External setpoint function	•	•	15.15.1 External setpoint influence	35
Predefined setpoints	• ¹⁾	• ¹⁾		
Temperature influence	•	-	15.15.3 Temperature influence	37
Monitoring functions	•	•	15.16 Monitoring functions	38
Motor bearing monitoring	•	•		
Motor bearing maintenance	•	•		
Limit-exceeded function	-	•	15.16.1 Limit-exceeded function	38
Special functions	•	•	15.17 Special functions	38
Pulse flow meter setup	-	•	15.17.1 Pulse flow meter setup	38
Ramps	-	•	15.17.2 Ramps	38
Standstill heating	•	•		
Communication	•	•	15.18 Communication	38
Pump number	•	•	15.18.1 Pump number	38
Enable/disable radio communication	•	•	15.18.2 Enable/disable radio communication	38
General settings	•	•	15.19 General settings	39

¹⁾ Only available if an advanced functional module is fitted.

Assist	TPE3 (D)	TPE2 (D)	Section	Page
Assisted pump setup	•	•		
Setup, analog input	•	•		
Setting of date and time	-	-		
Multi-pump setup	•	•	16.1 Multi-pump setup	39
Description of control mode	•	•		
Assisted fault advice	•	•		

14. Grundfos GO Remote

The pump is designed for wireless radio or infrared communication with the Grundfos GO Remote.

The Grundfos GO Remote enables setting of functions and gives access to status overviews, technical product information and actual operating parameters.

The Grundfos GO Remote offers the following mobile interfaces (MI). See fig. 33.

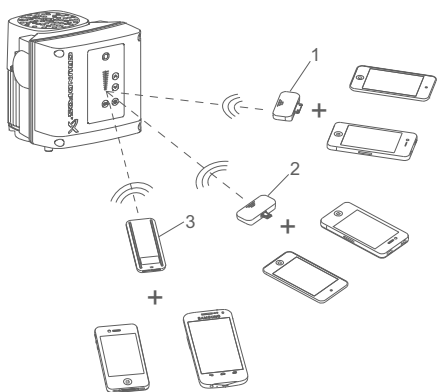

TM06 0744 0914

Fig. 33 Grundfos GO Remote communicating with the pump via radio or infrared connection (IR)

Pos.	Description
1	Grundfos MI 202: Add-on module which can be used in conjunction with an Apple iPhone or iPod with 30-pin connector and iOS 5.0 or later, e.g. fourth generation iPhone or iPod.
2	Grundfos MI 204: Add-on module which can be used in conjunction with an Apple iPhone or iPod with Lightning connector, e.g. fifth generation iPhone or iPod. (The MI 204 is also available together with an Apple iPod touch and a cover.)
3	Grundfos MI 301: Separate module enabling radio or infrared communication. The module can be used in conjunction with an Android or iOS-based smart device with Bluetooth connection.



14.1 Communication

When the Grundfos GO Remote communicates with the pump, the indicator light in the middle of the Grundfos Eye will flash green. See section 21. *Grundfos Eye*.

Communication must be established using one of these communication types:

- radio communication
- infrared communication.

14.1.1 Radio communication

Radio communication can take place at distances up to 30 meters. It is necessary to enable communication by pressing  or  on the pump control panel.

14.1.2 Infrared communication

When communicating via infrared light, the Grundfos GO Remote must be pointed at the pump control panel.

14.2 Menu overview for Grundfos GO Remote

14.2.1 Main menus

Dashboard	TPE3 (D)	TPE2 (D)
	•	•
Status	TPE3 (D)	TPE2 (D)
Resulting setpoint	•	•
Actual controlled value	•	•
Motor speed (rpm, %)	•	•
Power consumption	•	•
Energy consumption	•	•
Acc. flow, specific energy	•	•
Operating hours	•	•
Liquid temperature	•	-
Analog input 1	•	•
Analog input 2	•	•
Analog input 3	• ¹⁾	• ¹⁾
Pt100/1000 input 1	• ¹⁾	• ¹⁾
Pt100/1000 input 2	• ¹⁾	• ¹⁾
Analog output	• ¹⁾	• ¹⁾
Digital input 1	•	•
Digital input 2	• ¹⁾	• ¹⁾
Digital in/output 3	•	•
Digital in/output 4	• ¹⁾	• ¹⁾
Fitted modules	•	•
Trend data	•	-
Heat energy meter	•	-

¹⁾ Only available if an advanced functional module is fitted.

Settings	TPE3 (D)	TPE2 (D)	Section	Page
Setpoint	•	•	15.1 Setpoint	26
Operating mode	•	•	15.2 Operating mode	26
Control mode	•	•	15.4 Control mode	26
Date and time	• ¹⁾	• ¹⁾		
Flow limit	•	-	15.5 FLOWLIMIT	31
Automatic Night Setback	•	-	15.6 Automatic Night Setback	31
Temperature influence	•	-	15.15.3 Temperature influence	37
Buttons on product	•	•	15.19.3 Enable/disable settings	39
Controller	•	•	15.13 Controller settings	33
Operating range	•	•	15.14 Operating range	34
Ramps	-	•	15.17.2 Ramps	38
Pump number	•	•	15.18.1 Pump number	38
Radio communication	•	•	15.18.2 Enable/disable radio communication	38
Analog input 1	•	•		
Analog input 2	•	•	15.7 Analog inputs	31
Analog input 3	• ¹⁾	• ¹⁾		
Pt100/1000 input 1	• ¹⁾	• ¹⁾	15.8 Pt100/1000 inputs	31
Pt100/1000 input 2	• ¹⁾	• ¹⁾		
Digital input 1	•	•	15.9 Digital inputs	32
Digital input 2	• ¹⁾	• ¹⁾		
Digital in/output 3	•	•	15.10 Digital inputs/outputs	32
Digital in/output 4	• ¹⁾	• ¹⁾		
Predefined setpoint	• ¹⁾	• ¹⁾	15.15.2 Predefined setpoints	37
Analog output	• ¹⁾	• ¹⁾	15.12 Analog output	33
External setpoint funct.	•	•	15.15.1 External setpoint influence	35
Signal relay 1	•	•	15.11 Relay outputs	33
Signal relay 2	•	•		
Limit 1 exceeded	-	•	15.16.1 Limit-exceeded function	38
Limit 2 exceeded	-	•		
Standstill heating	•	•		
Motor bearing monitoring	•	•		
Service	•	•		
Store settings	•	•		
Recall settings	•	•		
Undo	•	•		
Pump name	•	•		
Unit configuration	•	•		

¹⁾ Only available if an advanced functional module is fitted.

Alarms and warnings	TPE3 (D)	TPE2 (D)
Alarm log	•	•
Warning log	•	•
"Reset alarm" button	•	•

Assist	TPE3 (D)	TPE2 (D)
Assisted pump setup	•	•
Assisted fault advice	•	•
Multipump setup	•	•

15. Description of selected functions

15.1 Setpoint

The setpoint for all control modes, except $AUTO_{ADAPT}$ and $FLOW_{ADAPT}$, can be set in this submenu when the desired control mode has been selected. See section 15.4 *Control mode*.

15.2 Operating mode

Possible operating modes:

- Normal
The pump runs according to the selected control mode.
- Stop
The pump stops.
- Min.
The minimum curve mode can be used in periods in which a minimum flow is required.
This operating mode is for instance suitable for manual night setback if "Automatic Night Setback" is not desired.
- Max.
The maximum curve mode can be used in periods in which a maximum flow is required.
This operating mode is for instance suitable for systems with hot-water priority.
- Manual
The pump is operating at a manually set speed.
See section 15.3 *Set manual speed*.

The pump can be set to operate according to the maximum or minimum curve, like an uncontrolled pump. See fig. 34.

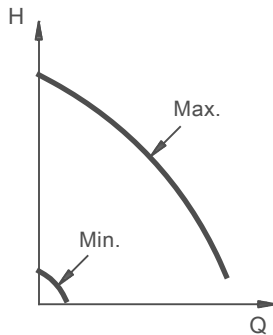

Fig. 34 Maximum and minimum curves

15.3 Set manual speed

The pump speed can be set in %. When the operating mode has been set to "Manual", the pump will run at the set speed.

15.4 Control mode

Possible control modes:

- $AUTO_{ADAPT}$
- $FLOW_{ADAPT}$
- Prop. press. (proportional pressure)
- Const. pressure (constant pressure)
- Const. temp. (constant temperature)
- Con. diff. press. (constant differential pressure)
- Con. diff. temp. (constant differential temperature)
- Const. flow rate (constant flow rate)
- Const. level (constant level)
- Const. other val. (constant other value)
- Const. curve (constant curve).

Note

The operating mode must be set to "Normal" before a control mode can be enabled.

You can change the setpoint for all control modes, except $AUTO_{ADAPT}$ and $FLOW_{ADAPT}$, in the "Setpoint" submenu under "Settings" when you have selected the desired control mode.

15.4.1 $AUTO_{ADAPT}$

Pump variant	$AUTO_{ADAPT}$
TPE3 (D)	•
TPE2 (D)	-

The $AUTO_{ADAPT}$ control mode continuously adapts the pump performance according to the actual system characteristic.

Note

You cannot set the setpoint manually.

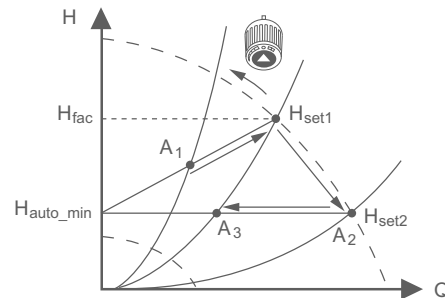

Fig. 35 $AUTO_{ADAPT}$

When you have enabled the $AUTO_{ADAPT}$ control mode, the pump will start with the factory setting, $H_{fac} = H_{set1}$, and then adjust its performance to A_1 . See fig. 35.

When the pump registers a lower head on the max. curve, A_2 , the $AUTO_{ADAPT}$ function will automatically select a correspondingly lower control curve, H_{set2} . If the valves in the system close, the pump will adjust its performance to A_3 .

- A_1 : Original duty point.
- A_2 : Lower registered head on the max. curve.
- A_3 : New duty point after $AUTO_{ADAPT}$ control.
- H_{set1} : Original setpoint setting.
- H_{set2} : New setpoint after $AUTO_{ADAPT}$ control.
- H_{fac} : Factory setting.
- H_{auto_min} : A fixed value of 5 ft (1.5 m).

The $AUTO_{ADAPT}$ control mode is a form of proportional-pressure control where the control curves have a fixed origin, H_{auto_min} . The $AUTO_{ADAPT}$ control mode has been developed specifically for heating systems and Grundfos do not recommend it for air-conditioning and cooling systems.

TM00 5547 0995

TM05 7910 1613

15.4.2 FLOW_{ADAPT}

Pump variant	FLOW _{ADAPT}
TPE3 (D)	•
TPE2 (D)	-

When you select FLOW_{ADAPT}, the pump will run AUTO_{ADAPT} and ensure that the flow never exceeds the entered FLOW_{LIMIT} value. The setting range for FLOW_{LIMIT} is 25 to 90 % of the Q_{max} of the pump.

The factory setting of the FLOW_{LIMIT} is the flow where the AUTO_{ADAPT} factory setting meets the maximum curve. See fig. 36.

Note Do not set the FLOW_{LIMIT} lower than the dimensioned duty point.

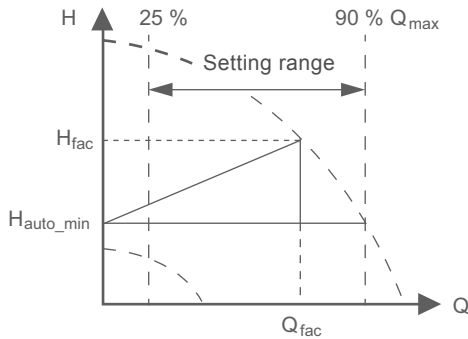

Fig. 36 FLOW_{ADAPT}

15.4.3 Proportional pressure

Pump variant	Proportional pressure
TPE3 (D)	•
TPE2 (D)	-

The pump head is reduced at decreasing water demand and increased at rising water demand. See fig. 37.

This control mode is especially suitable in systems with relatively large pressure losses in the distribution pipes. The head of the pump will increase proportionally to the flow in the system to compensate for the large pressure losses in the pipes.

The setpoint can be set with an accuracy of 0.33 ft (0.1 m). The head against a closed valve is half the setpoint, H_{set}/2.

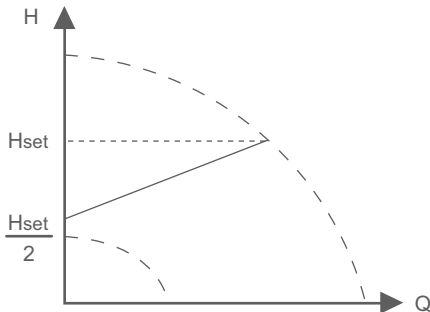

Fig. 37 Proportional pressure

Example

- Factory-fitted differential-pressure sensor.



Fig. 38 Proportional pressure

15.4.4 Constant pressure

Pump variant	Constant pressure
TPE3 (D)	-
TPE2 (D)	•

The pump maintains a constant discharge pressure, independently of the flow rate. See fig. 39.

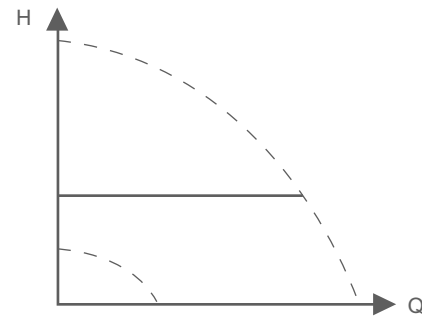

Fig. 39 Constant pressure

This control mode requires an external pressure sensor as shown in the examples below:

Examples

- One external pressure sensor.

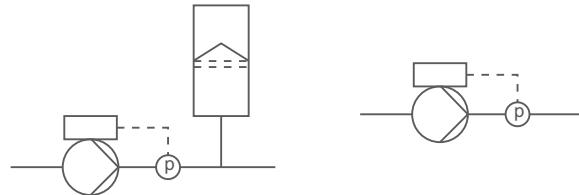

Fig. 40 Constant pressure

15.4.5 Constant temperature

Pump variant	Constant temperature
TPE3 (D)	•
TPE2 (D)	•

This control mode ensures a constant temperature. Constant temperature is a comfort control mode that can be used in domestic hot-water systems to control the flow to maintain a fixed temperature in the system. See fig. 41. When this control mode is used, no balancing valves must be installed in the system.

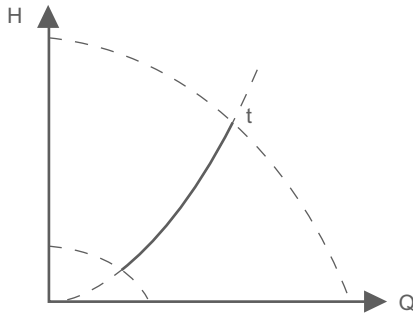
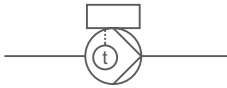

Fig. 41 Constant temperature

This control mode requires either an internal or external temperature sensor as shown in the examples below:

Examples

- Factory-fitted temperature sensor (only TPE3 (D)).



- One external temperature sensor.

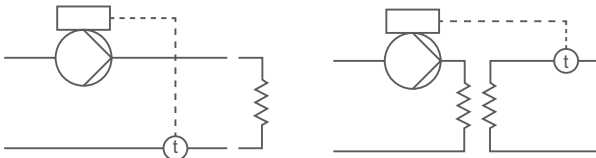

Fig. 42 Constant temperature

15.4.6 Constant differential pressure

Pump variant	Constant differential pressure
TPE3 (D)	•
TPE2 (D)	•

The pump maintains a constant differential pressure, independently of the flow in the system. See fig. 43. This control mode is primarily suitable for systems with relatively small pressure losses.

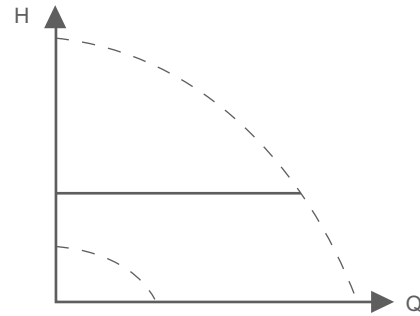
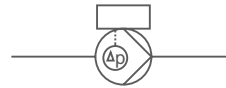

Fig. 43 Constant differential pressure

This control mode requires either an internal or external differential-pressure sensor or two external pressure sensors as shown in the examples below:

Examples

- Factory-fitted differential-pressure sensor (only TPE3 (D)).



- One external differential-pressure sensor.

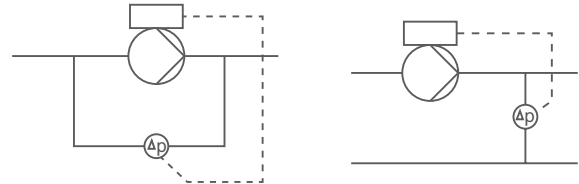

- Two external pressure sensors.

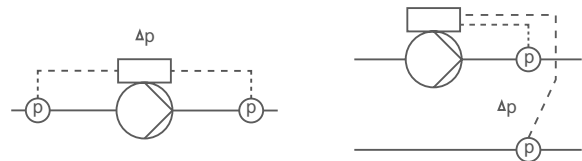
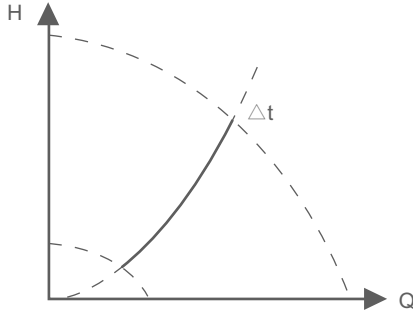

Fig. 44 Constant differential pressure

15.4.7 Constant differential temperature

Pump variant	Constant differential temperature
TPE3 (D)	•
TPE2 (D)	•

The pump maintains a constant differential temperature in the system and the pump performance is controlled according to this. See fig. 45.



TM05 7954 1713

Fig. 45 Constant differential temperature

This control mode requires either two temperature sensors or one external differential-temperature sensor as shown in the examples below:

Examples

- Factory-fitted temperature sensor and an external temperature sensor (only TPE3 (D)).

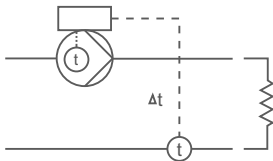

- Two external temperature sensors.

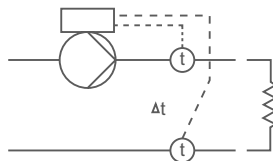

- One external differential-temperature sensor.

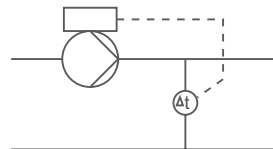
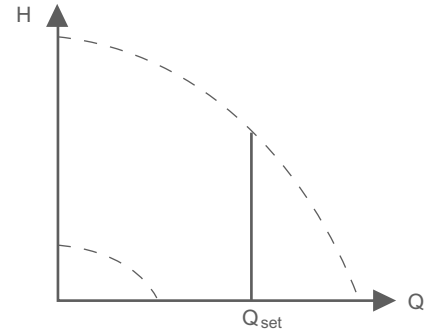

Fig. 46 Constant differential temperature

15.4.8 Constant flow rate

Pump variant	Constant flow rate
TPE3 (D)	-
TPE2 (D)	•

The pump maintains a constant flow in the system, independently of the head. See fig. 47.



TM05 7955 1713

Fig. 47 Constant flow rate

This control mode requires an external flow sensor as shown below:

Example

- One external flow sensor.

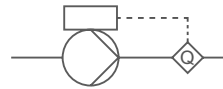
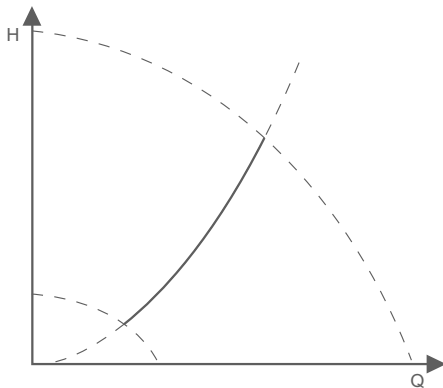

Fig. 48 Constant flow rate

15.4.9 Constant level

Pump variant	Constant level
TPE3 (D)	-
TPE2 (D)	•

The pump maintains a constant level, independently of the flow rate. See fig. 49.



TM05 7941 1613

Fig. 49 Constant level

This control mode requires an external level sensor.

The pump can control the level in a tank in two ways:

- as an emptying function where the pump draws the liquid from the tank.
- as a filling function where the pump pumps the liquid into the tank.

See fig. 50.

The type of level control function depends on the setting of the built-in controller. See section 15.13 Controller settings.

Examples

- One external level sensor. – emptying function.

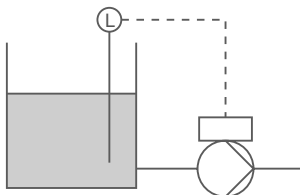

- One external level sensor. – filling function.

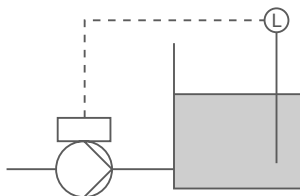

Fig. 50 Constant level

15.4.10 Constant other value

Pump variant	Constant other value
TPE3 (D)	-
TPE2 (D)	•

Any other value is kept constant.

15.4.11 Constant curve

Pump variant	Constant curve
TPE3 (D)	-
TPE2 (D)	•

You can set the pump to operate according to a constant curve, like an uncontrolled pump. See fig. 51.

You can set the desired speed in % of maximum speed in the range from 25 to 100 %.

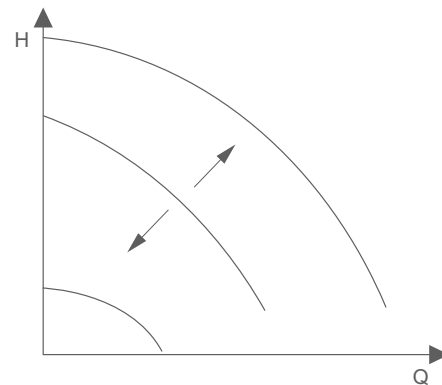

TM05 7957 1713

Fig. 51 Constant curve

Depending on the system characteristic and the duty point, the 100 % setting may be slightly smaller than the pump's actual maximum curve even though the display shows 100 %. This is due to power and pressure limitations built into the pump. The deviation varies according to pump type and pressure loss in the pipes.

Note

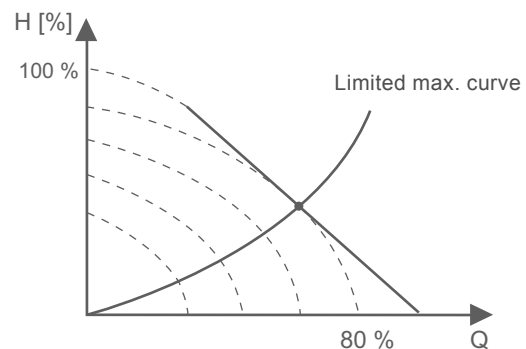

TM05 7913 1613

Fig. 52 Power and pressure limitations influencing the max. curve

15.5 FLOW_{LIMIT}

Pump variant	FLOW _{LIMIT}
TPE3 (D)	•
TPE2 (D)	-

FLOW_{LIMIT}

- Enable FLOW_{LIMIT} function.
- Set FLOW_{LIMIT}.

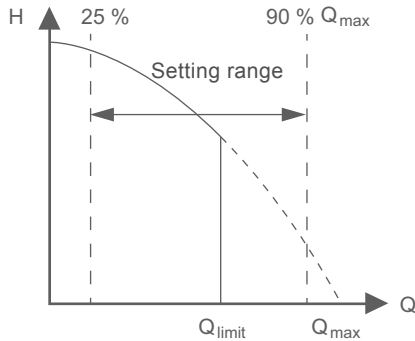

Fig. 53 FLOW_{LIMIT}

The FLOW_{LIMIT} function can be combined with the following control modes:

- Prop. press.
- Con. diff. press.
- Con. diff. temp.
- Const. temp.
- Const. curve.

A flow-limiting function ensures that the flow never exceeds the entered FLOW_{LIMIT} value.

The setting range for FLOW_{LIMIT} is 25 to 90 % of the Q_{max} of the pump.

The factory setting of the FLOW_{LIMIT} is the flow where the AUTO_{ADAPT} factory setting meets the maximum curve. See fig. 36.

15.6 Automatic Night Setback

Pump variant	Automatic Night Setback
TPE3 (D)	•
TPE2 (D)	-

Once you have enabled Automatic Night Setback, the pump automatically changes between normal duty and night setback (duty at low performance).

Changeover between normal duty and night setback depends on the flow-pipe temperature.

The pump automatically changes over to night setback when the built-in sensor registers a flow-pipe temperature drop of more than 18 to 27 °F (10 to 15 °C) within approx. two hours.

The temperature drop must be at least 1.8 °F/min (0.1 °C/min).

Changeover to normal duty takes place without a time lag when the temperature has increased by approx. 18 °F (10 °C).

Note

You cannot enable Automatic Night Setback when the pump is in constant-curve mode.

15.7 Analog inputs

Available inputs depending on the functional module fitted in the pump:

Function (terminal)	FM 200 (standard)	FM 300 (advanced)
Analog input 1, setup (4)	•	•
Analog input 2, setup (7)	•	•
Analog input 3, setup (14)	-	•

To set up an analog input, make the settings below.

Function

The analog inputs can be set to these functions:

- Not active
- Feedback sensor
- Ext. setpoint influence
See section 15.15 Setpoint influence
- Other function.

Measured parameter

Select one of the parameters, i.e. the parameter to be measured in the system by the sensor connected to the actual analog input.

Unit

Available measuring units:

Parameter	Possible units
Pressure	ft, psi, bar, m, kPa
Pump flow	gpm, m ³ /h, l/s, yd ³ /h
Liquid temperature	°F, °C
Other parameter	%

Electrical signal

Select signal type (0.5 - 3.5 V, 0-5 V*, 0-10 V, 0-20 mA or 4-20 mA).

Sensor range, min. value

Set the minimum value of the connected sensor.

Sensor range, max. value

Set the maximum value of the connected sensor.

15.8 Pt100/1000 inputs

Available inputs depending on the functional module fitted in the pump:

Function (terminal)	FM 200 (standard)	FM 300 (advanced)
Pt100/1000 input 1, setup (17 and 18)	-	•
Pt100/1000 input 2, setup (18 and 19)	-	•

Function

The Pt100/1000 inputs can be set to these functions:

- Not active
- Feedback sensor
- Ext. setpoint influence
See section 15.15 Setpoint influence
- Other function.

Measured parameter

Select one of the parameters, i.e. the parameter to be measured in the system.

TMM05 7908 1613

15.9 Digital inputs

Available inputs depending on the functional module fitted in the pump:

Function (terminal)	FM 200 (standard)	FM 300 (advanced)
Digital input 1, setup (2 and 6)	•	•
Digital input 2, setup (1 and 9)	-	•

To set up a digital input, make the settings below.

Function

Select one of these functions:

- Not active
When set to "Not active", the input has no function.
- External stop
When the input is deactivated (open circuit), the pump will stop.
- Min. (minimum speed)
When the input is activated, the pump will run at the set min. speed.
- Max. (maximum speed)
When the input is activated, the pump will run at the set max. speed.
- External fault
When the input is activated, a timer will be started. If the input is activated for more than 5 seconds, the pump will be stopped and a fault will be indicated.
- Alarm resetting
When the input is activated, a possible fault indication will be reset.
- Dry running
When this function has been selected, lack of inlet pressure or water shortage can be detected.
When lack of inlet pressure or water shortage (dry running) is detected, the pump will be stopped. The pump cannot restart as long as the input is activated.
This requires the use of an accessory, such as these:
 - a pressure switch installed on the suction side of the pump
 - a float switch installed on the suction side of the pump.
- Accumulated flow
When this function has been selected, the accumulated flow can be registered. This requires the use of a flowmeter which can give a feedback signal as a pulse per defined flow of water.
See section 15.17.1 *Pulse flow meter setup*.
- Predefined setpoint digit 1 (applies only to digital input 2)
When digital inputs are set to predefined setpoint, the pump will operate according to a setpoint based on the combination of the activated digital inputs.
See section 15.15.2 *Predefined setpoints*.

The priority of the selected functions in relation to each other appears from section 20. *Priority of settings*.

A stop command will always have the highest priority.

15.10 Digital inputs/outputs

Available inputs/outputs depending on the functional module fitted in the pump:

Function (terminal)	FM 200 (standard)	FM 300 (advanced)
Digital input/output 3, setup (10 and 16)	•	•
Digital input/output 4, setup (11 and 18)	-	•

To set up a digital input/output, make the settings below.

Mode

You can set the digital input/output 3 and 4 to act as digital input or digital output:

- Digital input
- Digital output.

Function

You can set the digital input/output 3 and 4 to these functions:

Possible functions, digital input/output 3

Function if input	Function if output
• Not active	• Not active
• External stop	• Ready
• Min.	• Alarm
• Max.	• Operation
• External fault	• Pump running
• Alarm resetting	• Warning
• Dry running	• Limit 1 exceeded*
• Accumulated flow*	• Limit 2 exceeded*
• Predefined setpoint digit 2	

* Only TPE2 (D).

Possible functions, digital input/output 4

Function if input	Function if output
• Not active	• Not active
• External stop	• Ready
• Min.	• Alarm
• Max.	• Operation
• External fault	• Pump running
• Alarm resetting	• Warning
• Dry running	• Limit 1 exceeded*
• Accumulated flow*	• Limit 2 exceeded*
• Predefined setpoint digit 3	

* Only TPE2 (D).

15.11 Relay outputs

Function (terminal)	FM 200 (standard)	FM 300 (advanced)
Relay output 1 (NC, C1, NO)	•	•
Relay output 2 (NC, C2, NO)	•	•

The pump incorporates two signal relays for potential-free signalling. See section 22. *Signal relays* for further information. You can configure the signal relays to be activated by one of the following incidents:

- Ready
- Operation
- Alarm
- Warning
- Limit 2 exceeded*
- Limit 1 exceeded*
- Pump running
- Relubricate
- Control of external fan
- Not active.

* Only TPE2 (D).

15.12 Analog output

Whether the analog output is available or not, depends on the functional module fitted in the pump:

Function (terminal)	FM 200 (standard)	FM 300 (advanced)
Analog output	-	•

To set up the analog output, make the settings below.

Output signal

- 0-10 V
- 0-20 mA
- 4-20 mA.

Function of analog output

- Actual speed
- Actual value
- Resulting setpoint
- Motor load
- Motor current
- Limit 1 exceeded*
- Limit 2 exceeded*
- Flow rate

* Only TPE2 (D).

15.13 Controller settings

Pump variant	Controller settings
TPE3 (D)	•
TPE2 (D)	•

The pumps have a factory default setting of gain (K_p) and integral time (T_i).

However, if the factory setting is not the optimum setting, you can change the gain and the integral time:

- Set the gain (K_p) within the range from 0.1 to 20.
- Set the integral-action time (T_i) within the range from 0.1 to 3600 s.
If you have selected 3600 s, the controller will function as a P controller.

Furthermore, you can set the controller to inverse control.

This means that if the setpoint is increased, the speed will be reduced. In the case of inverse control, set the gain (K_p) within the range from -0.1 to -20.

Guidelines for setting of PI controller

The tables below show the recommended controller settings:

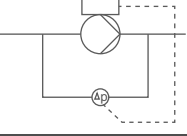
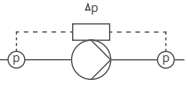
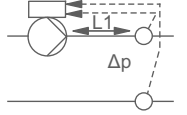
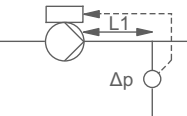
Differential-pressure control	K_p	T_i
	0.5	0.5
		
	0.5	L1 < 16.4 ft (5 m): 0.5 L1 > 16.4 ft (5 m): 3 L1 > 32.8 ft (10 m): 5
		

L1 = Distance ft (m) between pump and sensor.

Temperature control	K_p		T_i
	Heating system ¹⁾	Cooling system ²⁾	
	0.5	-0.5	10 + 5L2
	0.5	-0.5	30 + 5L2

- 1) In heating systems, an increase in pump performance will result in a rise in temperature at the sensor.
- 2) In cooling systems, an increase in pump performance will result in a drop in temperature at the sensor.

L2 = Distance ft (m) between heat exchanger and sensor.

Differential-temperature control	K_p	T_i
	-0.5	10 + 5L2

L2 = Distance ft (m) between heat exchanger and sensor.

Flow control	K_p	T_i
	0.5	0.5
Constant-pressure control	K_p	T_i
	0.5	0.5
	0.1	0.5

Level control	K_p	T_i
	-2.5	100
	2.5	100

General rules of thumb

If the controller is too slow-reacting, increase K_p .
 If the controller is hunting or unstable, dampen the system by reducing K_p or increasing T_i .

15.14 Operating range

Pump variant	Operating range
TPE3 (D)	•
TPE2 (D)	•

Set the operating range as follows:

- Set the minimum speed within the range from fixed minimum speed to user-set maximum speed.
- Set the maximum speed within the range from user-set minimum speed to fixed maximum speed.

The range between the user-set minimum and maximum speeds is the operating range. See fig. 54.

Note *Speeds below 25 % may result in noise from the shaft seal.*

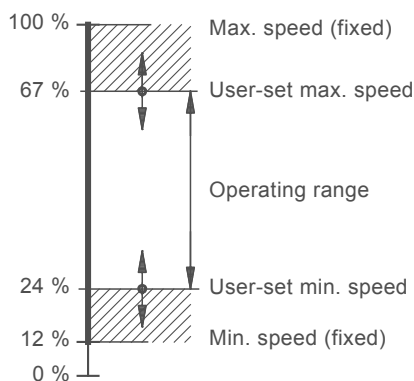

Fig. 54 Example of min. and max. settings

TM00 6785 5095

15.15 Setpoint influence

15.15.1 External setpoint influence

Pump variant	Setpoint influence
TPE3 (D)	•
TPE2 (D)	•

You can influence the setpoint by an external signal, either via one of the analog inputs or, if you fit an advanced functional module, via one of the Pt100/1000 inputs.

Before you can enable the "Digital inputs", set one of the analog inputs or Pt100/1000 inputs to "External setpoint function".

Note

See sections 15.7 Analog inputs and 15.8 Pt100/1000 inputs.

If more than one input has been set up for setpoint influence, the function will select the analog input with the lowest number, for example "Analog input 2", and ignore the other inputs, for example "Analog input 3" or "Pt100/1000 input 1".

Example

See fig. 55.

At a lower sensor value of 0 psi, a set setpoint of 29 psi and an external setpoint of 60 %, the actual setpoint is $0.60 \times (29 - 0) + 0 = 17.4$ psi.

Actual setpoint = actual input signal x (setpoint - lower value) + lower value.

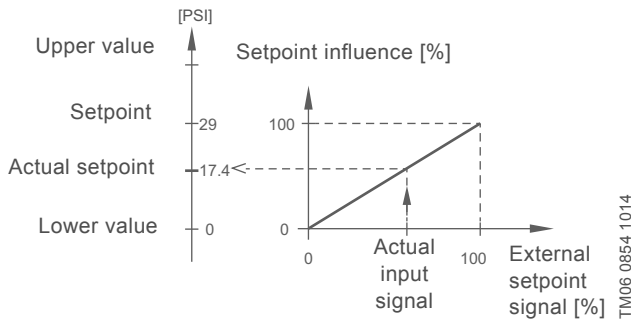

Fig. 55 Example of setpoint influence

The table below gives an overview of the types of setpoint influence and the availability depending on pump type.

Type of setpoint influence	Pump type	
	TPE3 (D)	TPE2 (D)
Not active	•	•
Linear function	•	•
Linear with Stop	-	•
Linear with Min.	•	•
Inverse function	-	•
Inverse with Stop	-	•
Inverse with Min.	-	•
Influence table	-	•
Influence table with Stop at Min.	-	•
Influence table with Stop at Max.	-	•

You can select these functions:

- Not active
When set to "Not active", the setpoint will not be influenced from any external function.
- Linear function
The setpoint is influenced linearly from 0 to 100 %. See fig. 56.

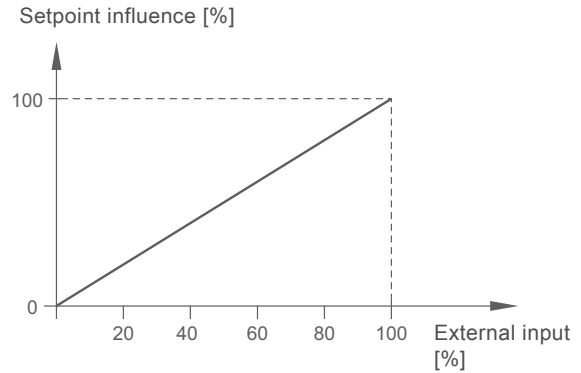

Fig. 56 Linear function

- "Linear with Stop" and "Linear with Min."
 - Linear with Stop
In the input signal range from 20 to 100 %, the setpoint is influenced linearly.
If the input signal is below 10 %, the pump will change to operating mode "Stop".
If the input signal is increased above 15 %, the operating mode will be changed back to "Normal".
See fig. 57.
 - Linear with Min.
In the input signal range from 20 to 100 %, the setpoint is influenced linearly.
If the input signal is below 10 %, the pump will change to operating mode "Min.".
If the input signal is increased above 15 %, the operating mode will be changed back to "Normal".
See fig. 57.

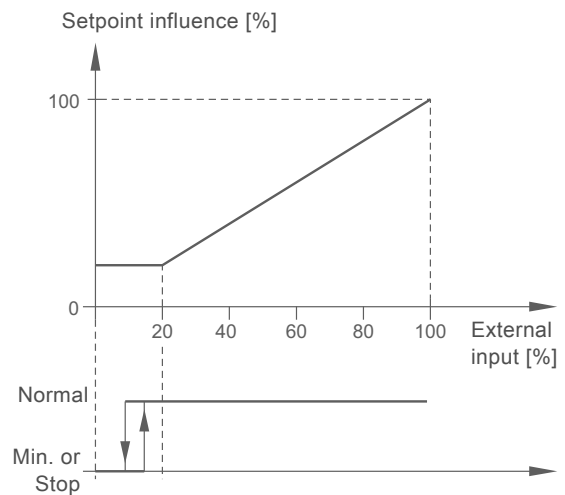

Fig. 57 "Linear with Stop" and "Linear with Min."

TM05 6280 4612

TM06 0854 1014

TM05 6281 4612

- Inverse function
The setpoint is influenced inversely from 0 to 100 %.
See fig. 58.

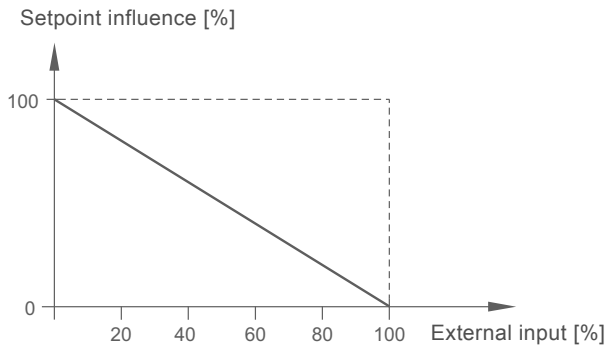

Fig. 58 Inverse function

- "Inverse with Stop" and "Inverse with Min."
 - Inverse with Stop
In the input signal range from 0 to 80 %, the setpoint is influenced inversely.
If the input signal is above 90 %, the pump will change to operating mode "Stop".
If the input signal is reduced below 85 %, the operating mode will be changed back to "Normal".
See fig. 59.
 - Inverse with Min.
In the input signal range from 0 to 80 %, the setpoint is influenced inversely.
If the input signal is above 90 %, the pump will change to operating mode "Min.".
If the input signal is reduced below 85 %, the operating mode will be changed back to "Normal".
See fig. 59.

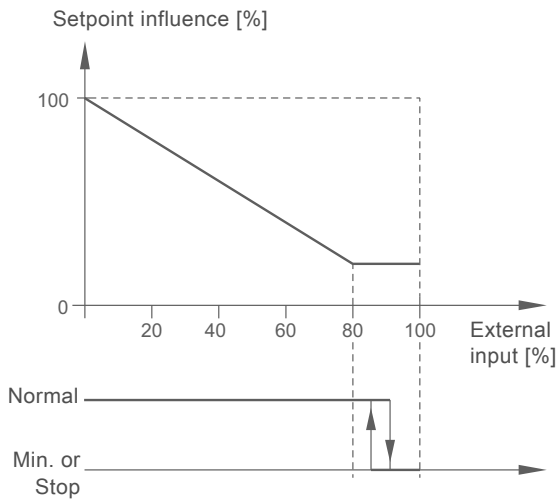

Fig. 59 "Inverse with Stop" and "Inverse with Min."

- Influence table
The setpoint is influenced by a curve made out of two to eight points. There will be a straight line between the points and a horizontal line before the first point and after the last point.

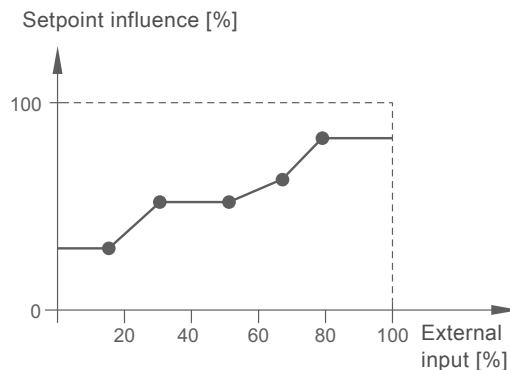

Fig. 60 Influence table

- Influence table with Stop at Min.
The setpoint is influenced by a curve made out of two to eight points. There will be a straight line between the points and a horizontal line before the first point and after the last point.
If the input signal is below 10 %, the pump will change to operating mode "Stop".
If the input signal is increased above 15 %, the operating mode will be changed back to "Normal".
See fig. 61.

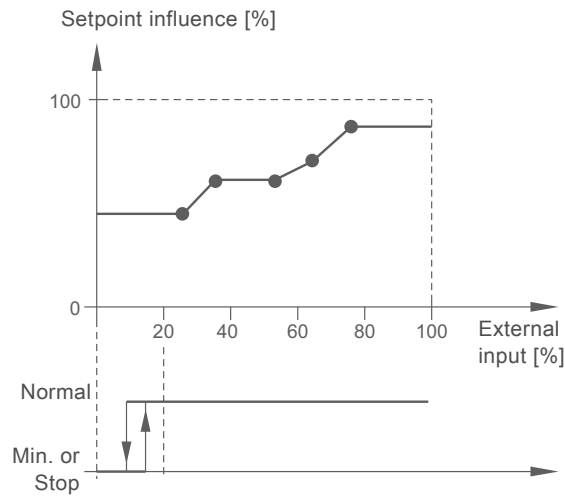

Fig. 61 Influence table with Stop at Min.

- Influence table with Stop at Max.
The setpoint is influenced by a curve made out of two to eight points. There will be a straight line between the points and a horizontal line before the first point and after the last point. If the input signal is above 90 %, the pump will change to operating mode "Min.". If the input signal is reduced below 85 %, the operating mode will be changed back to "Normal". See fig. 62.

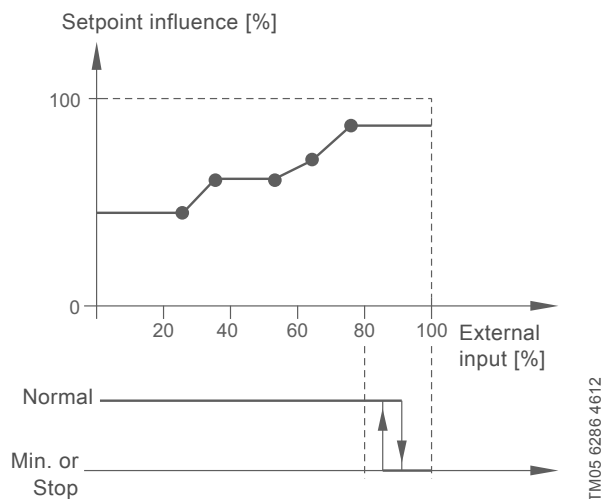

Fig. 62 Influence table with Stop at Max.

15.15.2 Predefined setpoints

Pump variant	Predefined setpoints
TPE3 (D)	•
TPE2 (D)	•

Seven predefined setpoints can be set and activated by combining the input signals to digital inputs 2, 3 and 4 as shown in the table below.

Digital inputs			Setpoint
2	3	4	
0	0	0	Normal setpoint
1	0	0	Predefined setpoint 1
0	1	0	Predefined setpoint 2
1	1	0	Predefined setpoint 3
0	0	1	Predefined setpoint 4
1	0	1	Predefined setpoint 5
0	1	1	Predefined setpoint 6
1	1	1	Predefined setpoint 7

15.15.3 Temperature influence

Pump variant	Temperature influence
TPE3 (D)	•
TPE2 (D)	-

When you enable this function in proportional- or constant-pressure control mode, the setpoint for head will be reduced according to the liquid temperature.

Temperature influence can be set to function at liquid temperatures below +176 °F or +122 °F (80 °C or 50 °C). These temperature limits are called T_{max} . The setpoint is reduced in relation to the head set (= 100 %) according to the characteristics below.

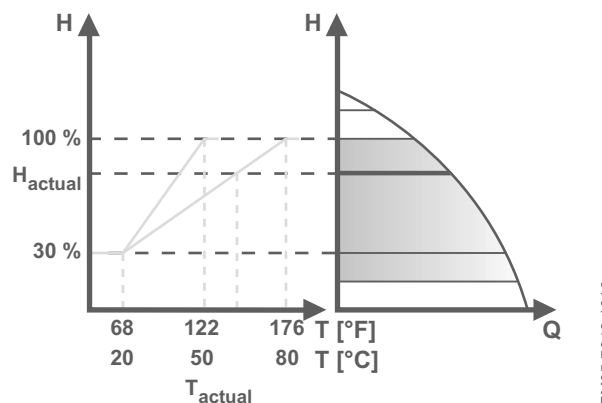

Fig. 63 Select the measured parameter of Pt100/1000 input 2

In the above example, T_{max} = +176 °F (+80 °C) has been selected.

The actual liquid temperature T_{actual} causes the setpoint for head to be reduced from 100 % to H_{actual} .

The temperature influence function requires the following:

- Proportional-pressure, constant-pressure or constant-curve control mode.
- Pump installed in flow pipe.
- System with flow-pipe temperature control.

Temperature influence is suitable for the following systems:

- Systems with variable flows (for example two-pipe heating systems) in which the enabling of the temperature influence function will ensure a further reduction of the pump performance in periods with small heating demands and consequently a reduced flow-pipe temperature.
- Systems with almost constant flows (for example one-pipe heating systems and underfloor heating systems), in which variable heating demands cannot be registered as changes in the head as is the case with two-pipe heating systems. In such systems, you can only adjust the pump performance by enabling the temperature influence function.

Selection of T_{max} .

In systems with a dimensioned flow-pipe temperature of:

- up to and including +131 °F (+55 °C), select T_{max} = +122 °F (+50 °C)
- above +131 °F (+55 °C), select T_{max} = +176 °F (80 °C).

Note You cannot use the temperature influence function in air-conditioning and cooling systems.

15.16 Monitoring functions

15.16.1 Limit-exceeded function

Pump variant	Limit-exceeded function
TPE3 (D)	-
TPE2 (D)	•

This function can monitor set limits of analog values. It will react if the values exceed the limits. Each limit can be set as a maximum or minimum value. For each of the monitored values, you must define a warning limit and an alarm limit.

The function makes it possible to monitor two different locations in a pump system at the same time. For instance the pressure at a consumer and the pump discharge pressure. This ensures that the discharge pressure does not reach a critical value.

If the value exceeds the warning limit, a warning is given. If the value exceeds the alarm limit, the pumps will be stopped.

You can set a delay between the detection of an exceeded limit and the activation of a warning or an alarm. You can also set a delay for resetting a warning or an alarm.

You can reset a warning automatically or manually.

Furthermore, you can set whether the system is to restart automatically after an alarm, or if the alarm must be reset manually. Restarting can be delayed by an adjustable time. You can also set a startup delay ensuring that the system reaches a steady state before the function becomes active.

15.17 Special functions

15.17.1 Pulse flow meter setup

Pump variant	Pulse flow meter setup
TPE3 (D)	-
TPE2 (D)	•

You can connect an external pulse flowmeter to one of the digital inputs in order to register the actual and accumulated flows. Based on this, you can also calculate the specific energy btu/lb (kWh/m^3).

To enable a pulse flowmeter, set one of the digital-input functions to "Accumulated flow" and set the pumped volume per pulse.

See section 15.9 *Digital inputs*.

15.17.2 Ramps

Pump variant	Ramps
TPE3 (D)	-
TPE2 (D)	•

The setting of ramps is only relevant in the case of constant-curve operation.

The ramps determine how quickly the motor can accelerate and decelerate, respectively, during start/stop or setpoint changes.

The following can be set:

- acceleration time, 0.1 to 300 s
- deceleration time, 0.1 to 300 s.

The times apply to the acceleration from stop to rated speed and the deceleration from rated speed to stop, respectively.

At short deceleration times, the deceleration of the motor may depend on load and inertia as there is no possibility of actively braking the motor.

If the power supply is switched off, the deceleration of the motor will only depend on load and inertia.

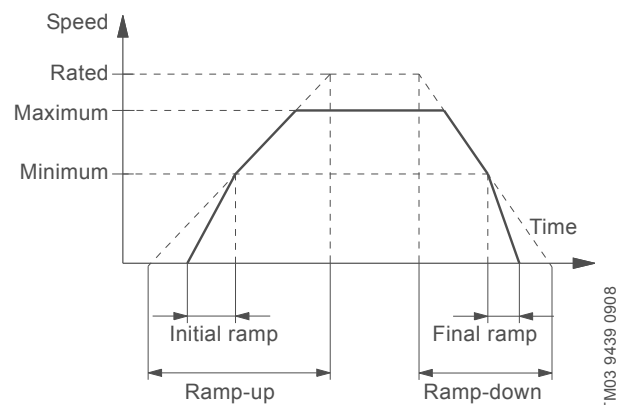

Fig. 64 Ramp-up and ramp-down

15.18 Communication

15.18.1 Pump number

Pump variant	Pump number
TPE3 (D)	•
TPE2 (D)	•

You can allocate a unique number to the pump. This makes it possible to distinguish between pumps in connection with bus communication.

15.18.2 Enable/disable radio communication

Pump variant	Pump number
TPE3 (D)	•
TPE2 (D)	•

You can set the radio communication to either enabled or disabled.

15.19 General settings

Pump variant	General settings
TPE3 (D)	•
TPE2 (D)	•

15.19.1 Language

A number of languages is available.

Measuring units are automatically changed according to selected language.

15.19.2 Units

In this menu you can select between US and SI units. The setting can be made generally for all parameters or customized for each individual parameter.

15.19.3 Enable/disable settings

In this display, you can disable the possibility of making settings for protective reasons.

Note

To unlock the pump and allow settings, press ∇ and \blacktriangle simultaneously for at least 5 seconds.

15.19.4 Delete history

In this menu you can delete the following historic data:

- Delete work log.
- Delete heat energy data.
- Delete energy consumption.

15.19.5 Define Home display

In this menu you can select whether the "Home" display should show various user-defined parameters or a graphical illustration of a performance curve with the actual duty point of the pump.

15.19.6 Display settings

In this menu you can adjust the display brightness and define whether or not the display should turn off if no buttons have been activated for a period of time.

15.19.7 Store actual settings

In this menu you can store the actual settings for later use.

15.19.8 Recall stored settings

In this menu you can recall the last stored settings that the pump will then use.

15.19.9 Run startup guide

The startup guide will guide you through the general settings of the pump.

16. Assist

16.1 Multi-pump setup

Pump variant	Multi-pump setup
TPE3 (D)	•
TPE2 (D)	•

The multipump function enables the control of single-head pumps connected in parallel or twin-head pumps without the use of external controllers. The pumps in a multipump system communicate with each other via the wireless GENIair connection or the wired GENI connection.

You set up a multipump system via a selected pump, i.e. the master pump (first selected pump). You can connect all Grundfos pumps with a wireless GENIair connection to the multipump system.

The multipump functions are described in the following sections.

16.1.1 Alternating operation

Only one pump is operating at a time.

The change from one pump to the other depends on time or energy. If a pump fails, the other pump will take over automatically.

Pump system:

- Twin-head pump.
- Two single-head pumps connected in parallel.
The pumps must be of the same type and size. Each pump requires a non-return valve in series with the pump.

16.1.2 Backup operation

One pump is operating continuously. The backup pump is operated at intervals to prevent seizing up. If the duty pump stops due to a fault, the backup pump will start automatically.

Pump system:

- Twin-head pump.
- Two single-head pumps connected in parallel.
The pumps must be of the same type and size. Each pump requires a non-return valve in series with the pump.

16.1.3 Cascade operation

Cascade operation ensures that the pump performance is automatically adapted to the consumption by switching pumps on or off. The system thus runs as energy-efficiently as possible with a constant pressure and a limited number of pumps.

When a twin-head pump is running in constant-pressure control mode, the second pump head will start at 90 % and stop at 50 % performance.

All pumps in operation will run at equal speed. Pump changeover is automatic and depends on energy, operating hours and fault.

Pump system:

- Twin-head pump.
- Two to four single-head pumps connected in parallel.
The pumps must be of the same type and size. Each pump requires a non-return valve in series with the pump.
- The control mode must be set to "Const. pressure" or "Const. curve".

17. Selection of control mode

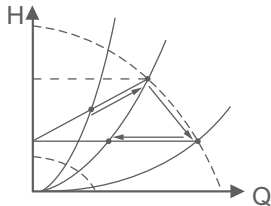
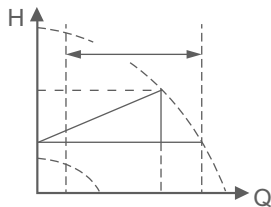
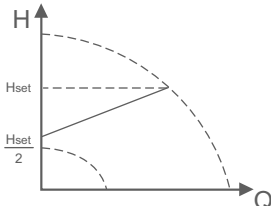
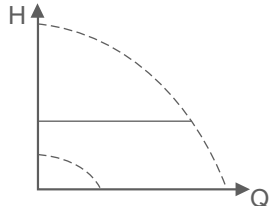
System application	Select this control mode
<p>Recommended for most heating systems, especially in systems with relatively large pressure losses in the distribution pipes. See description under proportional pressure. In replacement situations where the proportional-pressure duty point is unknown. The duty point has to be within the $AUTO_{ADAPT}$ operating range. During operation, the pump automatically makes the necessary adjustment to the actual system characteristic. This setting ensures minimum energy consumption and low noise level from valves, which reduces operating costs and increases comfort.</p>	<p style="text-align: center;">$AUTO_{ADAPT}$</p> 
<p>The $FLOW_{ADAPT}$ control mode is a combination of $AUTO_{ADAPT}$ and $FLOW_{LIMIT}$. This control mode is suitable for systems where you want a maximum flow limit, $FLOW_{LIMIT}$. The pump continuously monitors and adjusts the flow, thus ensuring that the selected $FLOW_{LIMIT}$ is not exceeded. Main pumps in boiler applications where a steady flow through the boiler is required. No extra energy is used for pumping too much liquid into the system. In systems with mixing loops, you can use the control mode to control the flow in each loop. Benefits:</p> <ul style="list-style-type: none"> • Enough water for all loops at peak load conditions if each loop has been set to the right maximum flow. • The dimensioned flow for each zone (required heat energy) is determined by the flow from the pump. This value can be set precisely in the $FLOW_{ADAPT}$ control mode without the use of pump throttling valves. • When the flow is set lower than the balancing valve setting, the pump will ramp down instead of losing energy by pumping against a balancing valve. • Cooling surfaces in air-conditioning systems can operate at high pressure and low flow. 	<p style="text-align: center;">$FLOW_{ADAPT}$</p> 
<p>In systems with relatively large pressure losses in the distribution pipes and in air-conditioning and cooling systems.</p> <ul style="list-style-type: none"> • Two-pipe heating systems with thermostatic valves and <ul style="list-style-type: none"> – very long distribution pipes – strongly throttled pipe balancing valves – differential-pressure regulators – large pressure losses in those parts of the system through which the total quantity of water flows (for example boiler, heat exchanger and distribution pipe up to the first branching). • Primary circuit pumps in systems with large pressure losses in the primary circuit. • Air-conditioning systems with <ul style="list-style-type: none"> – heat exchangers (fan coils) – cooling ceilings – cooling surfaces. 	<p style="text-align: center;">Proportional pressure</p> 
<p>In systems with relatively small pressure losses in the distribution pipes.</p> <ul style="list-style-type: none"> • Two-pipe heating systems with thermostatic valves and <ul style="list-style-type: none"> – dimensioned for natural circulation – small pressure losses in those parts of the system through which the total quantity of water flows (for example boiler, heat exchanger and distribution pipe up to the first branching) or – modified to a high differential temperature between flow pipe and return pipe (for example district heating). • Underfloor heating systems with thermostatic valves. • One-pipe heating systems with thermostatic valves or pipe balancing valves. • Primary circuit pumps in systems with small pressure losses in the primary circuit. 	<p style="text-align: center;">Constant differential pressure</p> 

System application
Select this control mode

In systems with a fixed system characteristic.

Examples:

- one-pipe heating systems
- boiler shunts
- systems with three-way valves
- domestic hot-water circulation.

You can use $FLOW_{LIMIT}$ with advantage to control the maximum circulation flow.

Constant temperature and constant differential temperature

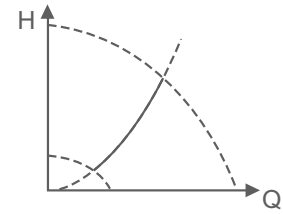

If you install an external controller, the pump is able to change from one constant curve to another, depending on the value of the external signal.

You can also set the pump to operate according to the maximum or minimum curve, like an uncontrolled pump:

- You can use the maximum curve mode in periods in which a maximum flow is required. This operating mode is for instance suitable for hot-water priority.
- You can use the minimum curve mode in periods in which a minimum flow is required. This operating mode is for instance suitable for manual night setback if you do not want Automatic Night Setback.

Constant curve

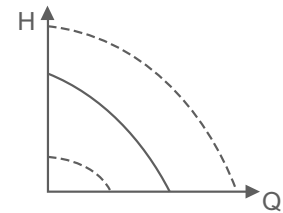

In systems requiring a constant flow, independently of pressure drop.

Examples:

- chillers for air-conditioning
- heating surfaces
- cooling surfaces.

Constant flow rate

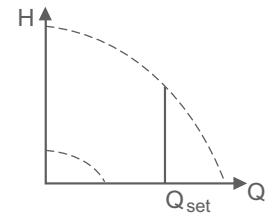

In systems requiring a constant tank level, independently of the flow rate.

Examples:

- process water tanks
- boiler condensate tanks.

Constant level

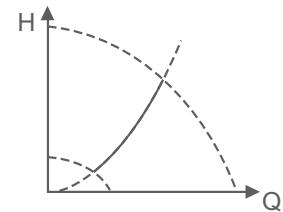

In systems with pumps operating in parallel.

The multipump function enables the control of single-head pumps connected in parallel (two to four pumps) and twin-head pumps without the use of external controllers. The pumps in a multipump system communicate with each other via the wireless GENIair connection or the wired GENI connection.

"Assist" menu
"Multi-pump setup"

18. Changing the position of the control panel

You can turn the control panel 180°. Follow the instructions below.

1. Loosen the four screws (TX25) holding the terminal box cover.

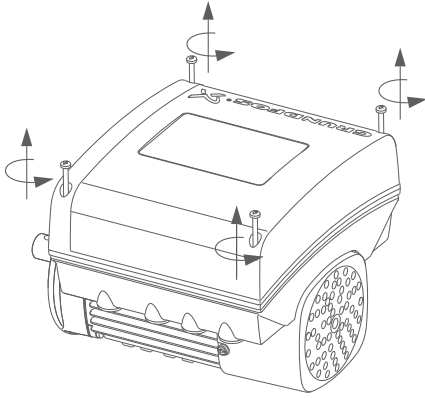

Fig. 65 Loosening the screws

2. Remove the terminal box cover.

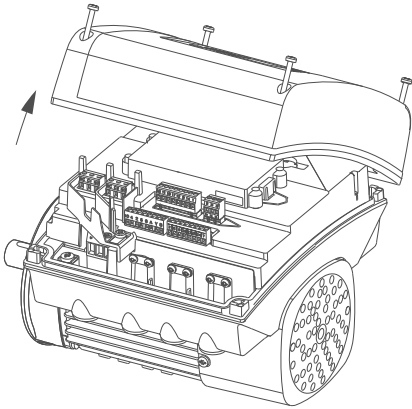

Fig. 66 Removing the terminal box cover

3. Press and hold in the two locking tabs (pos. A) while gently lifting the plastic cover (pos. B).

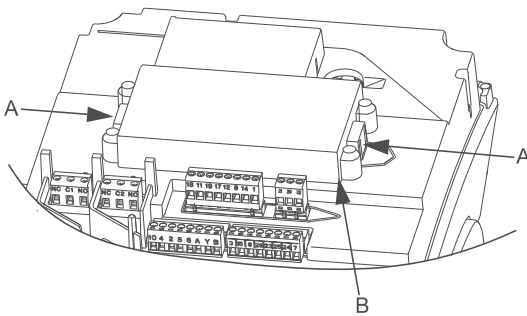

Fig. 67 Lifting the plastic cover

4. Turn the plastic cover 180°.

Note Do not twist the cable more than 90°.

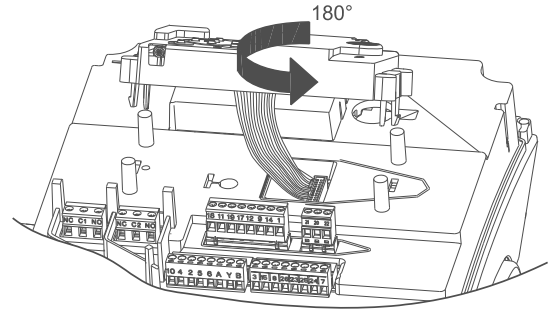

Fig. 68 Turning the plastic cover

5. Reposition the plastic cover correctly on the four rubber pins (pos. C). Make sure that the locking tabs (pos. A) are placed correctly.

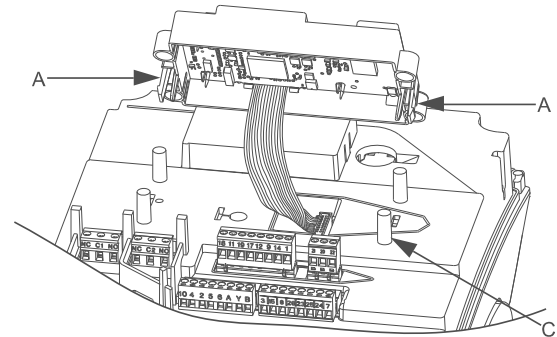

Fig. 69 Re-positioning the plastic cover

6. Fit the terminal box cover, and make sure that it is also turned 180° so that the buttons on the control panel are aligned with the buttons on the plastic cover. Tighten the four screws (TX25) with 3.69 lbf-ft (5 Nm).

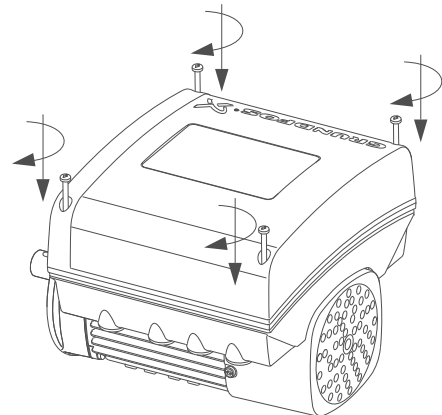

Fig. 70 Fitting the terminal box cover

TM05 5351 3612

TM05 5352 3612

TM05 5353 3612

TM05 5354 3612

TM05 5355 3612

TM05 5356 3612

19. Bus signal

The motor enables serial communication via an RS-485 input. The communication is carried out according to the Grundfos GENIbus protocol and enables connection to a building management system or another external control system.

Via a bus signal, you can remote-set motor operating parameters, such as setpoint and operating mode. At the same time, the motor can, via the bus, provide status information about important parameters, such as actual value of control parameter, input power and fault indications.

Contact Grundfos for further information.

Note

If you use a bus signal, the number of settings available via the Grundfos GO Remote will be reduced.

20. Priority of settings

You can always set the motor to operation at maximum speed or to stop with the Grundfos GO Remote.

If you enable two or more functions at the same time, the motor will operate according to the function with the highest priority.

Example: If, via the digital input, the motor has been set to maximum speed, the motor control panel or the Grundfos GO Remote can only set the motor to "Manual" or "Stop".

The priority of the settings appears from the table below:

Priority	Start/stop button	Grundfos GO Remote or control panel on motor	Digital input	Bus communication
1	Stop			
2		Stop*		
3		Manual		
4		Max. speed*		
5			Stop	
6				Stop
7				Max. speed
8				Min. speed
9				Start
10			Max. speed	
11		Min. speed		
12			Min. speed	
13			Start	
14		Start		

* If the bus communication is interrupted, the motor will resume its previous operating mode, for example "Stop", selected with the Grundfos GO Remote or on the motor control panel.

21. Grundfos Eye

The Grundfos Eye indicate the operating condition of the motor on the control panel. See fig. 71, pos. A.

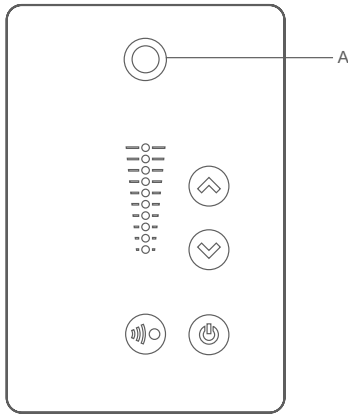

TM05 5993 4312

Fig. 71 Grundfos Eye













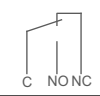





























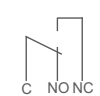





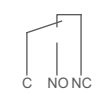











Grundfos Eye	Indication	Description
	No lights on.	Power off. Motor not running.
	Two opposite green indicator lights rotating in the direction of rotation of the motor when seen from the non-drive end.	Power on. Motor running.
	Two opposite green indicator lights permanently on.	Power on. Motor not running.
	One yellow indicator light rotating in the direction of rotation of the motor when seen from the non-drive end.	Warning. Motor running.
	One yellow indicator light permanently on.	Warning. Motor stopped.
	Two opposite red indicator lights flashing simultaneously.	Alarm. Motor stopped.
	The green indicator light in the middle flashes quickly four times.	Remote control with the Grundfos GO Remote via radio. The motor is trying to communicate with the Grundfos GO Remote. The motor in question is highlighted in the Grundfos GO Remote display to inform the user of the location of the motor.
	The green indicator light in the middle flashes continuously.	When the motor in question is selected in the Grundfos GO Remote menu, the green indicator light in the middle will flash continuously. Press on the motor control panel to allow remote control and data exchange via the Grundfos GO Remote.
	The green indicator light in the middle is permanently on.	Remote control with the Grundfos GO Remote via radio. The motor is communicating with the Grundfos GO Remote via radio connection.
	The green indicator light in the middle flashes quickly while the Grundfos Go Remote is exchanging data with the motor. It will take a few seconds.	Remote control with the Grundfos GO Remote via infrared light. The motor is receiving data from the Grundfos GO Remote via infrared communication.

22. Signal relays

The motor has two outputs for potential-free signals via two internal relays.

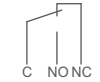
The signal outputs can be set to "Operation", "Pump running", "Ready", "Alarm" and "Warning".

The functions of the two signal relays appear from the table below:

Description	Grundfos Eye	Contact position for signal relays when activated					Operating mode
		Operation	Pump running	Ready	Alarm	Warning	
Power off.	 Off						-
Pump running in "Normal" mode.	 Green, rotating						Normal, Min. or Max.
Pump running in "Manual" mode.	 Green, rotating						Manual
Pump in operating mode "Stop".	 Green, steady						Stop
Warning, but the pump is running.	 Yellow, rotating						Normal, Min. or Max.
Warning, but the pump is running in "Manual" mode.	 Yellow, rotating						Manual
Warning, but the pump was stopped via "Stop" command.	 Yellow, steady						Stop
Alarm, but the pump is running.	 Red, rotating						Normal, Min. or Max.
Alarm, but the pump is running in "Manual" mode.	 Red, rotating						Manual
Pump stopped due to an alarm.	 Red, flashing						Stop

23. Maintenance and service



Warning

Before starting work on the pump, make sure that the power supply has been switched off for at least 5 minutes. Make sure that the power supply cannot be accidentally switched on.



Warning

Make sure that the escaping water does not cause injury to persons or damage to the equipment.



Warning

If the pump is used for a liquid which is injurious to health, it will be classified as contaminated. In such cases, the proper precautions must be taken to avoid injury to health when operating or working on the pump.

23.1 Maintenance

23.1.1 Pump

The pump is maintenance-free.

If the pump is to be drained for a long period of inactivity, inject a few drops of silicone oil on the shaft between the motor stool and the coupling. This will prevent the shaft seal faces from sticking.

23.1.2 Motor

The motor must be checked at regular intervals. It is important to keep the motor clean in order to ensure adequate ventilation. If the pump is installed in a dusty environment, clean and check the pump regularly.

23.2 Service

If Grundfos is requested to service the pump, it must be cleaned before it is returned.

If proper cleaning is not possible, all relevant information about the pumped liquid must be provided.

If the above is not fulfilled, Grundfos can refuse to accept the pump for service.

Possible costs of returning the pump are to be paid by the customer.

23.2.1 Integral shaft/coupling

TPE2 and TPE3 pumps have integral shaft/coupling.

We recommend that you do not remove the motor.

If the motor has been removed, it is necessary to remove the motor stool in order to refit the motor correctly. Otherwise the shaft seal may be damaged.

23.2.2 Blanking flanges

For twin-head pumps, a blanking flange with a pump housing gasket is available. See fig. 72.

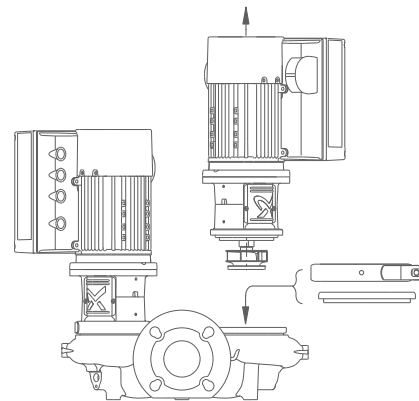

Fig. 72 Fitting the blanking flange

If one pump requires service, the blanking flange is fitted to allow the other pump to continue operating.

TM05 7921 1613

24. Fault finding



Warning

Before removing the terminal box cover or removing/dismantling the pump, make sure that the power supply has been switched off for at least 5 minutes. Make sure that the power supply cannot be accidentally switched on.



Warning

Make sure that the escaping water does not cause injury to persons or damage to the equipment.

Fault	Cause/remedy
1. Motor does not run when started.	<ul style="list-style-type: none"> a) Supply failure. b) Fuses blown. c) Motor defective.
2. Motor alarm when the power supply is switched on.	<ul style="list-style-type: none"> a) Supply failure. b) Cable connection loose or faulty. c) Motor winding defective. d) Pump mechanically blocked.
3. Occasional motor alarm.	<ul style="list-style-type: none"> a) Supply voltage periodically too low or too high. b) Differential pressure across pump too low.
4. No motor alarm, but the pump does not run.	<ul style="list-style-type: none"> a) Check the power supply. b) Check fuses.
5. Pump capacity not constant.	<ul style="list-style-type: none"> a) Pump inlet pressure too low. b) Suction pipe/pump partly blocked by impurities. c) Pump draws in air.
6. Pump runs but delivers no water.	<ul style="list-style-type: none"> a) Suction pipe/pump blocked by impurities. b) Foot or non-return valve blocked in closed position. c) Leakage in suction pipe. d) Air in suction pipe or pump.
7. Pump runs backwards when switched off.*	<ul style="list-style-type: none"> a) Leakage in suction pipe. b) Foot or non-return valve defective. c) Foot or non-return valve blocked in open or partly open position.
8. Leakage in shaft seal.	<ul style="list-style-type: none"> a) Shaft seal defective.
9. Noise.	<ul style="list-style-type: none"> a) Pump is cavitating. b) Pump does not rotate freely (frictional resistance) because of incorrect pump shaft position. c) Resonance in the installation. d) Foreign bodies in the pump.

* In twin-head pump installations, the backup pump will often rotate slowly.

25. Megging

Caution

Megging of an installation incorporating MGE motors is not allowed, as the built-in electronics may be damaged.

26. Technical data, single-phase motors

26.1 Supply voltage

- 1 x 200-240 V - 10 %/+ 10 %, 60 Hz, PE.

Check that the supply voltage and frequency correspond to the values stated on the nameplate.

Recommended fuse size

Motor size [hp (kW)]	Min. [A]	Max. [A]
0.25 - 1.0 (0.12 - 0.75)	6	10
1.5 - 2.0 (1.1 - 1.5)	10	16

You can use standard as well as quick-blow or slow-blow fuses.

26.2 Leakage current

Earth leakage current < 3.5 mA (AC supply).

Earth leakage current < 10 mA (DC supply).

The leakage currents are measured in accordance with EN 61800-5-1:2007.

27. Technical data, three-phase motors

27.1 Supply voltage

- 3 x 440-480 V - 10 %/+ 10 %, 60 Hz, PE.

Check that the supply voltage and frequency correspond to the values stated on the nameplate.

Recommended fuse size

Motor size [hp (kW)]	Min. [A]	Max. [A]
0.25 - 1.5 (0.12 - 1.1)	6	6
2.0 - 3.0 (1.5 - 2.2)	6	10

Standard as well as quick-blow or slow-blow fuses may be used.

27.2 Leakage current

Motor size [hp (kW)]	Leakage current [mA]
1.0 - 3.0 (0.75 - 2.2) (supply voltage < 400 V)	< 3.5
1.0 - 3.0 (0.75 - 2.2) (supply voltage > 400 V)	< 5

The leakage currents are measured in accordance with EN 61800-5-1:2007.

28. Inputs/outputs

Ground reference (GND)

All voltages refer to GND.

All currents return to GND.

Absolute maximum voltage and current limits

Exceeding the following electrical limits may result in severely reduced operating reliability and motor life:

Relay 1:

Maximum contact load: 250 VAC, 2 A or 30 VDC, 2 A.

Relay 2:

Maximum contact load: 30 VDC, 2 A.

GENI terminals: -5.5 to 9.0 VDC or < 25 mADC.

Other input/output terminals: -0.5 to 26 VDC or < 15 mADC.

Digital inputs (DI)

Internal pull-up current > 10 mA at $V_i = 0$ VDC.

Internal pull-up to 5 VDC (currentless for $V_i > 5$ VDC).

Certain low logic level: $V_i < 1.5$ VDC.

Certain high logic level: $V_i > 3.0$ VDC.

Hysteresis: No.

Screened cable: 20-16 AWG (0.5 - 1.5 mm²).

Maximum cable length: 1640 ft (500 m)

Open-collector digital outputs (OC)

Current sinking capability: 75 mADC, no current sourcing.

Load types: Resistive or/and inductive.

Low-state output voltage at 75 mADC: Max. 1.2 VDC.

Low-state output voltage at 10 mADC: Max. 0.6 VDC.

Overcurrent protection: Yes.

Screened cable: 20-16 AWG (0.5 - 1.5 mm²).

Maximum cable length: 1640 ft (500 m)

Analog inputs (AI)

Voltage signal ranges:

- 0.5 - 3.5 VDC, AL AU.
- 0-5 VDC, AU.
- 0-10 VDC, AU.

Voltage signal: $R_i > 100$ k Ω at 77 °F (+25 °C).

Leak currents may occur at high operating temperatures.

Keep the source impedance low.

Current signal ranges:

- 0-20 mADC, AU.
- 4-20 mADC, AL AU.

Current signal: $R_i = 292$ Ω .

Current overload protection: Yes. Change to voltage signal.

Measurement tolerance: - 0/+ 3 % of full scale (max.-point coverage).

Screened cable: 20-16 AWG (0.5 - 1.5 mm²).

Maximum cable length: 1640 ft (500 m) (excl. potentiometer).

Potentiometer connected to +5 V, GND, any AI:

Use maximum 10 k Ω .

Maximum cable length: 328 ft (100 m).

Analog output (AO)

Current sourcing capability only.

Voltage signal:

- Range: 0-10 VDC.
- Minimum load between AO and GND: 1 k Ω .
- Short-circuit protection: Yes.

Current signal:

- Ranges: 0-20 and 4-20 mA DC.
- Maximum load between AO and GND: 500 Ω .
- Open-circuit protection: Yes.

Tolerance: - 0/+ 4 % of full scale (max-point coverage).

Screened cable: 20-16 AWG (0.5 - 1.5 mm²).

Maximum cable length: 1640 ft (500 m)

Pt100/1000 inputs (PT)

Temperature range:

- Minimum -22 °F (-30 °C) (88 Ω /882 Ω).
- Maximum 356 °F (+180 °C) (168 Ω /1685 Ω).

Measurement tolerance: \pm 2.7 °F (1.5 °C).

Measurement resolution: < 0.54 °F (0.3 °C).

Automatic range detection (Pt100 or Pt1000): Yes.

Sensor fault alarm: Yes.

Screened cable: 20-16 AWG (0.5 - 1.5 mm²).

Use Pt100 for short wires.

Use Pt1000 for long wires.

LiqTec sensor inputs*

Use Grundfos LiqTec sensor only.

Screened cable: 20-16 AWG (0.5 - 1.5 mm²).

Power supplies (+5 V, +24 V)**+5 V:**

- Output voltage: 5 VDC - 5 %/+ 5 %.
- Maximum current: 50 mA DC (sourcing only).
- Overload protection: Yes.
- Sensor.

+24 V:

- Output voltage: 24 VDC - 5 %/+ 5 %.
- Maximum current: 60 mA DC (sourcing only).
- Overload protection: Yes.

Digital outputs (relays)

Potential-free changeover contacts.

Minimum contact load when in use: 5 VDC, 10 mA.

Screened cable: 20-12 AWG (0.5 - 2.5 mm²).

Maximum cable length: 1640 ft (500 m)

Bus input

Grundfos GENIbus protocol, RS-485.

Screened 3-core cable: 20-16 AWG (0.5 - 1.5 mm²).

Maximum cable length: 1640 ft (500 m)

29. Other technical data**EMC (electromagnetic compatibility)**

EN 61800-3.

Residential areas, unlimited distribution, corresponding to CISPR 11, class B, group 1.

Industrial areas, unlimited distribution, corresponding to CISPR 11, class A, group 1.

Contact Grundfos for further information.

Enclosure class

Standard: IP55 (IEC 34-5).

Optional: IP66 (IEC 34-5).

Insulation class

F (IEC 85).

29.1 Torques

Terminal	Thread size	Max. torque [lbf-ft (Nm)]
L1, L2, L3, L, N	M4	1.3 (1.8)
NC, C1, C2, NO	M2.5	0.4 (0.5)
1 to 26 and A, Y, B	M2	0.4 (0.5)

29.2 Sound pressure level

The sound pressure level will be below 70 dB

30. Disposal

This product or parts of it must be disposed of in an environmentally sound way:

1. Use the public or private waste collection service.
2. If this is not possible, contact the nearest Grundfos company or service workshop.

The waste battery should be disposed of through the local collective services. If in doubt, contact your local Grundfos company.

Subject to alterations.

1. Installation in the USA and Canada

Note

In order to maintain the cURus approval, follow these additional installation instructions. The UL approval is according to UL 1004-1.

1.1 Electrical codes

For USA

This product complies with the Canadian Electrical Code and the US National Electrical Code.

This product has been tested according to the national standards for Electronically Protected Motors:

CSA 22.2 100.04: 2009 (applies to Canada only).

UL 1004-1: June 2011 (applies to USA only).

Pour le Canada

Codes de l'électricité

Ce produit est conforme au Code canadien de l'électricité et au Code national de l'électricité américain.

Ce produit a été testé selon les normes nationales s'appliquant aux moteurs protégés électroniquement:

CSA 22.2 100.04: 2009 (s'applique au Canada uniquement).

UL 1004-1: Juin 2011 (s'applique aux États-Unis uniquement).

1.2 Radio communication

For USA

This device complies with part 15 of the FCC rules and RSS210 of IC rules.

Operation is subject to the following two conditions:

- This device may not cause interference.
- This device must accept any interference, including interference that may cause undesired operation of the device.

Pour le Canada

Communication radio

Ce dispositif est conforme à la partie 15 des règles de la FCC et aux normes RSS210 de l'IC.

Son fonctionnement est soumis aux deux conditions suivantes:

- Ce dispositif ne doit pas provoquer de brouillage préjudiciable.
- Il doit accepter tout brouillage reçu, y compris le brouillage pouvant entraîner un mauvais fonctionnement.

1.3 Identification numbers

For USA

Grundfos Holding A/S

Contains FCC ID: OG3-RADIOM01-2G4.

For Canada

Grundfos Holding A/S

Model: RADIOMODULE 2G4

Contains IC: 10447A-RA2G4M01.

Pour le Canada

Numéros d'identification

Grundfos Holding A/S

Modèle: RADIOMODULE 2G4

Contient IC: 10447A-RA2G4M01.

Location of identification numbers

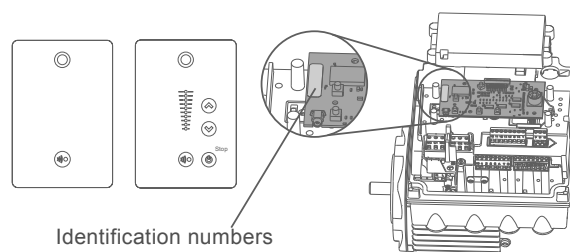

Identification numbers

Fig. 1 Identification numbers

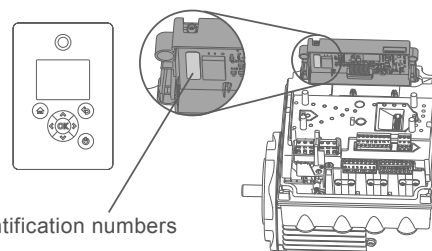

Identification numbers

Fig. 2 Identification numbers

1.4 Electrical connection

1.4.1 Conductors

Use 140/167 °F (60/75 °C) copper conductors only.

1.4.2 Torques

Maximum tightening torques for the terminals can be found in section 29.1 *Torques*, page 50.

1.4.3 Line reactors

Maximum line reactor size must not exceed 1.5 mH.

1.4.4 Fuse size/circuit breaker

If a short-circuit occurs, the pump can be used on a mains supply delivering not more than 5000 RMS symmetrical amperes, 600 V maximum.

Motor size [hp (kW)]	Fuse size	Circuit breaker type/model
0.50 to 3.0 (0.25 to 2.2)	25 A	25 A / inverse time

Fuses

When the motor is protected by fuses, they must be rated for 480 V. Maximum sizes are stated in the table above.

Motors up to and including 3.0 hp (2.2 kW) require class K5 UR fuses.

Circuit breaker

When the pump is protected by a circuit breaker, this must be rated for a maximum voltage of 480 V. The circuit breaker must be of the "inverse time" type.

The interrupting rating (RMS symmetrical amperes) must not be less than the values stated in the table above.

1.4.5 Overload protection

Degree of overload protection provided internally by the drive, in percent of full-load current: 102 %.

Appendix

US: Inlet pressure stated in bar relative pressure (pressure gauge value measured on the suction side of the pump)

Pump type	p [psi (bar)]					
	68 °F (20 °C)	140 °F (60 °C)	194 °F (90 °C)	230 °F (110 °C)	248 °F (120 °C)	248 °F (120 °C)
TPE2, TPE3 (D) 40-80	1.5 (0.1)	1.5 (0.1)	2.9 (0.2)	13.1 (0.9)	21.8 (1.5)	45 (3.1)
TPE2 (D), TPE3 (D) 40-120	1.5 (0.1)	1.5 (0.1)	2.9 (0.2)	13.1 (0.9)	21.8 (1.5)	45 (3.1)
TPE2 (D), TPE3 (D) 40-150	1.5 (0.1)	1.5 (0.1)	7.3 (0.5)	17.4 (1.2)	26.1 (1.8)	49.3 (3.4)
TPE2 (D), TPE3 (D) 40-180	1.5 (0.1)	1.5 (0.1)	8.7 (0.6)	18.9 (1.3)	27.6 (1.9)	50.8 (3.5)
TPE2 (D), TPE3 (D) 40-200	1.5 (0.1)	2.9 (0.2)	10.2 (0.7)	20.3 (1.4)	29 (2.0)	52.2 (3.6)
TPE2 (D), TPE3 (D) 40-240	1.5 (0.1)	4.4 (0.3)	11.6 (0.8)	21.8 (1.5)	30.5 (2.1)	53.7 (3.7)
TPE2 (D), TPE3 (D) 50-60	1.5 (0.1)	1.5 (0.1)	7.3 (0.5)	17.4 (1.2)	26.1 (1.8)	49.3 (3.4)
TPE2 (D), TPE3 (D) 50-80	1.5 (0.1)	4.4 (0.3)	11.6 (0.8)	21.8 (1.5)	30.5 (2.1)	53.7 (3.7)
TPE2 (D), TPE3 (D) 50-120	5.8 (0.4)	8.7 (0.6)	16 (1.1)	26.1 (1.8)	34.8 (2.4)	58 (4.0)
TPE2 (D), TPE3 (D) 50-150	8.7 (0.6)	11.6 (0.8)	18.9 (1.3)	29 (2.0)	37.7 (2.6)	60.9 (4.2)
TPE2 (D), TPE3 (D) 50-180	10.2 (0.7)	13.1 (0.9)	20.3 (1.4)	30.5 (2.1)	39.2 (2.7)	62.4 (4.3)
TPE2 (D), TPE3 (D) 50-200	13.1 (0.9)	16 (1.1)	23.2 (1.6)	33.4 (2.3)	42.1 (2.9)	65.3 (4.5)
TPE2 (D), TPE3 (D) 50-240	13.1 (0.9)	16 (1.1)	23.2 (1.6)	33.4 (2.3)	42.1 (2.9)	65.3 (4.5)
TPE2 (D), TPE3 (D) 65-60	1.5 (0.1)	1.5 (0.1)	2.9 (0.2)	13.1 (0.9)	21.8 (1.5)	45 (3.1)
TPE2 (D), TPE3 (D) 65-80	1.5 (0.1)	1.5 (0.1)	4.4 (0.3)	16 (1.1)	24.7 (1.7)	47.9 (3.3)
TPE2 (D), TPE3 (D) 65-120	1.5 (0.1)	2.9 (0.2)	8.7 (0.6)	20.3 (1.4)	29 (2)	52.2 (3.6)
TPE2 (D), TPE3 (D) 65-150	1.5 (0.1)	2.9 (0.2)	10.2 (0.7)	21.8 (1.5)	30.5 (2.1)	53.7 (3.7)
TPE2 (D), TPE3 (D) 65-180	4.4 (0.3)	7.3 (0.5)	14.5 (1.0)	26.1 (1.8)	34.8 (2.4)	56.6 (3.9)
TPE2 (D), TPE3 (D) 65-200	8.7 (0.6)	11.6 (0.8)	18.9 (1.3)	30.5 (2.1)	39.2 (2.7)	60.9 (4.2)
TPE2 (D), TPE3 (D) 80-40	1.5 (0.1)	1.5 (0.1)	4.4 (0.3)	14.5 (1)	23.2 (1.6)	46.4 (3.2)
TPE2 (D), TPE3 (D) 80-120	1.5 (0.1)	4.4 (0.3)	13.1 (0.9)	21.8 (1.5)	30.5 (2.1)	53.7 (3.7)
TPE2 (D), TPE3 (D) 80-150	1.5 (0.1)	4.4 (0.3)	13.1 (0.9)	21.8 (1.5)	30.5 (2.1)	53.7 (3.7)
TPE2 (D), TPE3 (D) 80-180	4.4 (0.3)	7.3 (0.5)	16 (1.1)	24.7 (1.7)	33.4 (2.3)	56.6 (3.9)
TPE2 (D), TPE3 (D) 100-40	1.5 (0.1)	1.5 (0.1)	5.8 (0.4)	16 (1.1)	24.7 (1.7)	45 (3.1)
TPE2 (D), TPE3 (D) 100-120	1.5 (0.1)	1.5 (0.1)	8.7 (0.6)	18.9 (1.3)	27.6 (1.9)	50.8 (3.5)
TPE2 (D), TPE3 (D) 100-150	1.5 (0.1)	2.9 (0.2)	10.2 (0.7)	20.3 (1.4)	29 (2)	52.2 (3.6)
TPE2 (D), TPE3 (D) 100-180	1.5 (0.1)	4.4 (0.3)	11.6 (0.8)	21.8 (1.5)	30.5 (2.1)	53.7 (3.7)

GRUNDFOS Kansas City

17100 West 118th Terrace
Olathe, Kansas 66061
Phone: (913) 227-3400
Fax: (913) 227-3500

www.grundfos.us

Grundfos CBS Inc.

902 Koomey Road
Brookshire, TX 77423 USA
Phone: 281-994-2700
Toll Free: 1-800-955-5847
Fax: 1-800-945-4777

www.grundfosexpresssuite.com

GRUNDFOS Canada

2941 Brighton Road
Oakville, Ontario L6H 6C9 Canada
Phone: +1-905 829 9533
Telefax: +1-905 829 9512

www.grundfos.ca

GRUNDFOS México

Boulevard TLC No. 15
Parque Industrial Stiva Aeropuerto
C.P. 66600 Apodaca, N.L. México
Phone: 011-52-81-8144 4000
Fax: 011-52-81-8144 4010

www.grundfos.mx

98653472 0115
ECM: 1150808

The name Grundfos, the Grundfos logo, and be think innovate are registered trademarks owned by Grundfos Holding A/S or Grundfos A/S, Denmark. All rights reserved worldwide. © Copyright Grundfos Holding A/S